

Operating Instruction

Mobile Processing Shredder

EP 5500 Shark

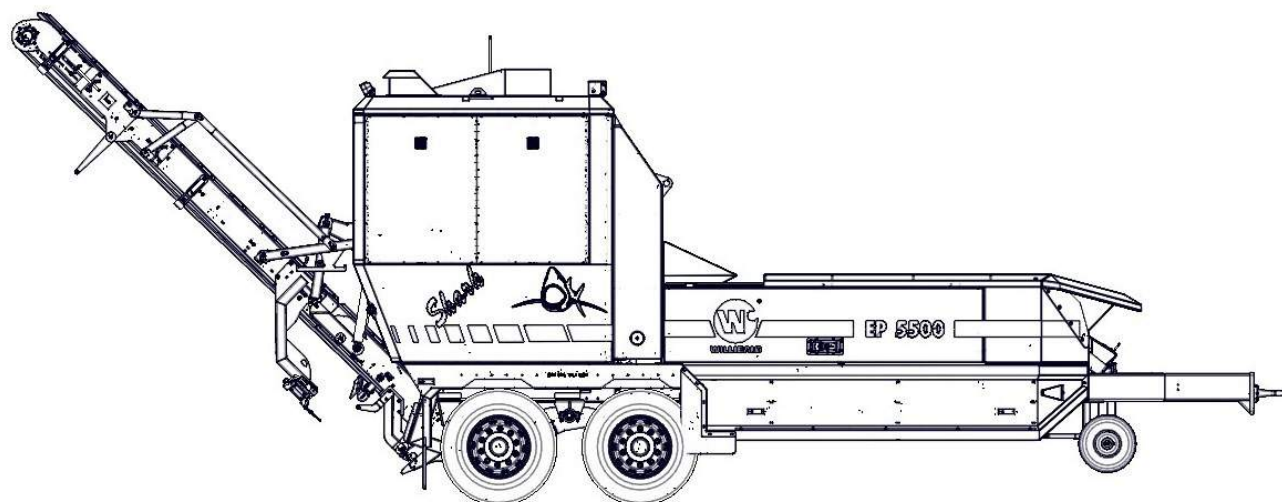

TRANSLATION OF THE ORIGINAL INSTRUCTIONS

Table of contents

	Page	
1.0	GENERAL	6
1.1	Foreword	6
1.2	Operator's obligation	6
1.3	Undertakings to be given by the personnel	6
1.4	Explanation of symbols	7
1.5	Guarantee and liability	8
1.5.1	Warranty and fair trading requests	8
1.5.2	Acknowledgement and compensation	9
1.5.3	Special agreements	9
1.6	Copyright	10
2.0	DESCRIPTION OF THE PRODUCT	11
2.1	Tasks of the machine	11
2.2	Intended use	12
2.3	Working place	13
2.4	Technical characteristics	15
2.5	Equipment	16
3.0	SAFETY PRESCRIPTIONS	20
3.1	Personnel requirements	20
3.1.1	Skills	20
3.1.2	Training of personnel	20
3.1.3	Personal protective equipment	21
3.1.4	Informal safety measures	22
3.1.4.1	Symbols and markings on the machine	22
3.1.4.2	Overview labels and warning signs	23
3.1.4.3	Illustration labels and warning signs	24
3.1.4.5	Position labels and warning signs	27
3.2	SAFETY INFORMATION and potential dangers in use of the machine	31
3.2.1	Protective devices	31
3.2.2	Safety precautions to be observed during normal duty	31
3.2.3	Machine control	31
3.2.4	EMERGENCY STOP device	32
3.2.5	Dangers caused by electric energy	33
3.2.6	Dangers caused by hydraulic energy	33
3.2.7	Passing out of noxious steams and gases	34
3.2.8	Noise level produced by the machine	34
3.2.9	Service and maintenance, elimination of faults	34
3.2.10	Constructional modification of machine	35
3.2.11	Cleaning of machine and disposal	36
3.3	WARNINGS and special dangers in use of the machine	37
3.3.1	Fire hazard in motor compartment	37
3.3.2	Fire hazard by replenishing with fuel	37
3.3.3	Damage resulting from crystallized reducing agent AdBlue (Carbamide)	38
3.3.4	Danger due to strong magnetic fields	39
3.3.5	Dangers due to hot surface or liquid	39
3.3.6	Danger by filling the machine	40
3.3.7	Danger by hydraulic feed-hopper	41

3.3.8	Danger by discharge conveyor	41
3.3.9	Danger due rotating rotor	42
3.3.10	Danger due rotating idler roll and power belt	42
4.0	FUNCTIONING	43
4.1	Processing task	43
4.2	Construction	43
4.3	Functional principle	43
4.4	Safety equipment	45
4.4.1	Emergency off button	45
4.4.2	Motor Stop key	45
4.4.3	Main battery switch	46
4.4.5	Siren	46
4.5	Safety equipment for maintenance and repair work	47
4.5.1	Motor hood securing	47
4.5.2	Coupling securing	48
4.5.3	Infeed roller securing	49
4.5.4	Discharge conveyor securing	50
5.0	DESCRIPTION W- TRONIC 2600	51
5.1	Overview	51
5.2	OPERATION Functions – control at the control box / remote control unit	52
5.3	Description of the W.tronic 2600 chain drive (with crawler only)	53
5.4	Quick dialing functions at the control box / remote control unit	54
5.5	OPERATION Service – control	55
5.6	User variables - Description	58
5.7	Error number – description	60
5.8	Description of the radio remote control	61
5.9	Description of the W-tronic 2600 reversible ventilator	64
5.10	Description of central lubrication	65
5.11	Description calibration FLAP / RAKE: (optional sensors for FLAP / RAKE is required)	67
5.12	Description LED von Plate stock 250 ST V1.2	68
5.13	Automatic start / stop function	69
5.14	Fuel pump function	69
	Plug arrangement LEDs	74
5.15	Annex: Connection diagrams W-tronic 2600 V1.8	74
6.0	COMMISSIONING / START-UP	75
6.1	Introduction	75
6.2	Transport of the EP 5500 Shark	78
6.3	Start-up of the machine	81
6.3.1	Safety information	81
6.3.2	Setting up the EP 5500 Shark	81
6.3.3	Motor hood opening	82
6.3.4	Checking the hydraulic oil level	83
6.3.5	Checking the motor oil level	83
6.3.6	Checking the diesel fuel level	84
6.3.7	Checking the coolant level	84
6.3.8	Checking the AdBlue- System	85
6.3.9	Motor hood closing	85

7.0	OPERATION	86
7.1	Starting, short description	86
7.2	Adjustments	88
7.3	Turning out, short description	89
7.4	Emergency-Off function	90
7.4.1	Press back the idler roll	90
7.5	Transfer of machine	92
7.5.1	Transfer machine without wheel drive	92
7.5.2	Transfer machine with wheel drive	93
7.6	Turning of the EP 5500 Shark, start of a new compost windrow forming procedure	94
7.7	Replacement of wear parts	95
7.7.1	Taking the discharge conveyor in maintenance position	96
7.7.2	Replacement of flails	99
7.7.3	Replacement the rakes of crushing basket	105
7.7.4	Replacement of the shredding flap	107
7.7.5	Replacement of power belt	108
7.8	Fault indication at the control	110
7.9	Service diagnosis / Fault finding table	112
8.0	MAINTENANCE	115
8.1	Lubrication plan	118
8.2	Other maintenance and service routines	119
8.3	Replacement of the trailer coupling ring	121
8.4	Replacement of brake linings	121
8.5	Changing of wheels	121
8.6	Changing of hydraulic oil	121
8.7	Recommended hydraulic oil types	122
8.7.1	Oil filling amounts for the gear	124
8.8	Grease types to be applied	124
8.9	Refill coolant	124
8.10	AdBlue	125
8.11	Proof of service routines	126
8.12	Service addresses	127
9.0	REPAIR	128
10.0	PUTTING THE MACHINE OUT OF ACTION	128
11.0	CLEANING AND CARING	129
11.1	Indoor cleaning	129
11.1.1	Motor compartment	129
11.2	Outdoor cleaning	129
12.0	DISPOSAL	130
13.0	INSTRUCTIONS FOR ORDERING OF SPARE PARTS	131
14.0	Inventory list	132
15.0	Annex: Undertakings to be given by the personnel	134
16.0	General terms and conditions	135

PRODUCT IDENTIFICATION

Machine type : EP 5500 Shark
 Year of construction :
 Machine-No. :
 Chassis-No. :
 Motor type :
 Motor-No. :

Manufacturer address :

J. Willibald GmbH
Bahnhofstrasse 6
D-88639 Wald-Sentehart
Phone-number : +49 (0) 7578 / 189 0
Fax-number : +49 (0) 7578 / 189 170
E-mail-address : info@willibald-gmbh.de

Dealers address :

Clients Service Address :

The vehicle identification plate is attached to draw bar, right in the direction of travel of the machine.

J. WILLIBALD GmbH		Maschinenfabrik D 88639 Wald-Sentehart	
W09		CE	
Total	kg	Typ	
Axle 1	kg		
Axle 2	kg		
		Stützpl. 1000 kg	
		Pin max load	

Maschine mit Motor - Flexregelung	
laufende Nr.	/ 50
Motor-Typ	Deutz TCD 6.1 L06 Sr.-Nr.
	MAN D2676 LE Sr.-Nr.
	MAN D0836 LE 124 Sr.-Nr.
Typpr.-Nr.	Deutz e1*97 / 68LA*2011/88*0659*01
	MAN e4*97 / 68LA*2010/26*0308*00
	MAN e4*97 / 68LA*2010/26*0272*00

1.0 GENERAL

1.1 Foreword

Thoroughly read and observe all information, warnings and safety notes contained in this operation manual *before* commissioning of the machine.

- Knowledge of all basic safety information and warnings contained in this operation manual as well as of the safety prescriptions is the basic prerequisite for the appropriate handling and trouble free operating of this machine.
- This operation manual contains all important information necessary in order to operate the machine in an appropriate and safe manner.
- This operation manual, especially the safety information contained herein, must be observed by all persons working on or with the machine.
- In addition, all rules and prescriptions valid and in force at the place of operation must thoroughly be observed and complied with by all means.

1.2 Operator's obligations

The operator is obliged and undertakes to only allow persons to work on or with the machine who

- are no younger than 18 years;
- are familiar with all basic rules and prescriptions operative and in force in regard to safety at work and to accident prevention and who have been introduced into the handling of this machine and have been assigned to their duties;
- Have read and fully understood the chapter contained in this manual referring to safety information and warnings and who have confirmed to have done so by their signature.
- The operator undertakes to control his personnel in regard to safety conscious working.

1.3 Undertakings to be given by the personnel

Before starting to work, all persons charged to work on or with this machine commit themselves

- to observe the basic rules and prescriptions valid and in force in regard to safety at work and prevention of accidents;
- to read the chapter on safety information and warnings contained in this operation manual and to confirm to have fully understood its contents and to have done so by their own signature. See you table on the page 134.

1.4 Explanation of symbols

In this operation manual the following safety symbols, warnings and descriptions are used to mark possible dangers:



DANGER

This symbol indicates an imminently dangerous situation which will result in death or serious injury if the safety measures are not followed.

Inobservance of this guidance entails serious consequences to the health of persons and can cause severe bodily or fatal injuries.



WARNING

This symbol indicates a potentially dangerous situation that can result in death or serious injury if the safety measures are not followed. Inobservance of this guidance can entail serious consequences to the health of persons, be causal for severe bodily injuries or be fatal.



CAUTION

This symbol indicates a potentially dangerous situation that can lead to minor injuries when security measures are not followed. Inobservance of this guidance may result in light injuries or be causal for damage to property.



NOTICE

This symbol indicates a potential for property damage which may arise when security measures are not followed.

This symbol indicates important information given in regard to the appropriate handling of the machine.

Inobservance of this information may result in disturbance or malfunction of the machine or may cause interferences with the environment.



This symbol indicates important information, application tips as well as other useful information.

The above symbols are to help you to utilize all functions of your machine in the best possible way.

1.5 Guarantee and liability

Basically, our "General Standard Sales and Delivery Conditions" are operative, of which the operator, at its latest, will receive a copy at the date of the conclusion of contract. See annex on the page 135. The producer does not assume liability for any personal injury and damage to property whatsoever if any such damage is attributable to one or several of the following causes:

- Machine not applied in compliance with the intended use;
- Inexpert mounting, commissioning, start-up, handling and servicing of the machine;
- Operation of machine with defective, inoperative or not properly mounted safety devices and protective gear;
- Non-observance of information and warnings contained in this operation manual in regard to transport, mounting, commissioning, operation and set-up of the machine;
- Use of parts that aren't original WILLIBALD spare parts;
- Unauthorized constructional modification of the machine;
- Unauthorized modification of the EP 5500 Shark (e.g. gear ratios, output and r.p.m.), hydraulic pressure;
- Insufficient control of machine parts subject to wear;
- Repairs performed in an inexpert manner;
- Disasters caused by the influence of foreign bodies or substances or by force majors.

1.5.1 Warranty and fair trading requests

a) Warranty and fair trading requests require written form. Here our warranty and fair trading request form must be used.

b) Parts, units or sets changed under the guarantee coverage must - without being asked to do so - be provided to us *free of costs* for detailed examination and be sent in no later than four 4 weeks after occurrence of the damage complained about.

c) Basically, all spare parts, sets and units ordered from us will be billed to our customers, no matter if needed for any works to be performed under the granted guarantee coverage or not. A possible credit note can take place only after examination and acknowledgment of the appropriate warranty and fair trading request.

d) Transport damages do not go in principle to our loads.

e) Warranty or fair trading requests is to have arrived 2 weeks, at the latest 4 weeks after damage entrance with us. Later received requests can be worked on only after previous arrangement.

1.5.2 Acknowledgement and compensation

If the customer's application for services to be rendered under the granted guarantee coverage and/or for accommodation ex gratia was acknowledged, WILLIBALD shall compensate for the following:

a) After our discretion and in the context of our business obligation appearing necessary construction units, see page 126 of maintenance proof.

b) Subject to our discretion: all expenditure of works as deemed necessary for the replacement of parts and components under said guarantee coverage.

c) Subject to our discretion: costs spent on travelling to WILLIBALD, which applied only, however, if the customer – due to important reasons – cannot be expected to visit an after-sales-workshop. The compensation from hourly rate and km are from Willibald for guarantees stated.

d) Maintenance and service routines and related expense of works do not form part of the guarantee coverage. Same also applies if the customer has failed to perform such work and routines as prescribed to the result of damages caused to the machine, which the customer tries to have retrieved by works rendered under the granted guarantee term. For cargo is normal transport compensate, only. No Express.

e) Fundamental applies:

The exclusive WILLIBALD - original spare parts must be used.

1.5.3 Special agreements

Any guarantee terms other than the terms set forth herein must be in writing.

Guarantee terms operative for WILLIBALD machines:

a) The guarantee term granted is 12 months as of the date of delivery.

b) The guarantee for elements and technical components used in the machine other than of our own make, such as engine, hydraulic pumps, hydraulic motors, electronically components etc. can only be assumed insofar as we ourselves can enforce claims against our suppliers under the guarantee coverage granted to us, and only to such extent as we are entitled to receive such performances.

c) The above guarantee does not include wear parts, such as flails, plug-in shaft, tool kit, V-belts, filters, bearing etc.

1.6 Copyright

The company J. WILLIBALD GmbH holds the sole copyright in present operation manual. This operation manual is for the exclusive use by the operator and his personnel.

It contains prescriptions, information and notes, which may neither partially nor completely

- be copied
- distributed or
- communicated otherwise.

Contravention to the above may entail penal measures and result in legal consequences.

J. WILLIBALD GmbH
Machine fabric

2.0 DESCRIPTION OF THE PRODUCT

The Machine EP 5500 Shark is built according to the state of the art and the recognized safety rules.

2.1 Tasks of the machine

- Defibration of organic material of thicknesses of up to 30 cm for composting (gardening wastes, material from the landscape development, sawn timber, wastes from cemeteries).
- Shredding (volume reduction) of used or waste wood to thicknesses of up to 30 cm.

*Illustration 2.1
EP 5500 Shark
Side view*

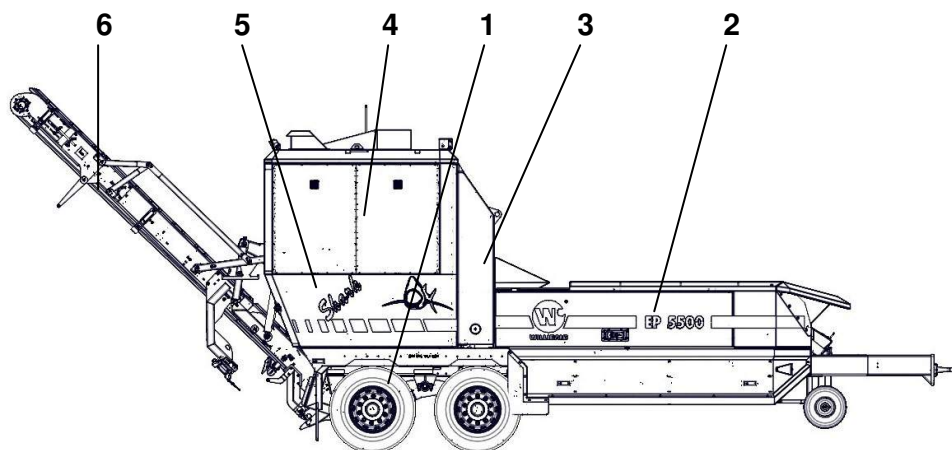

1. Track laying chassis
2. Chute with draw-in unit
3. Feed rollers
4. Motor
5. Shredding unit
6. Discharge conveyor

Inexpert use of the machine can result in serious injury to the user or third, respectively, damage to the machine or other property. The machine must be applied only:

- for its intended use;
- in perfect condition that as regards safety technique only.

Any disturbances or malfunctions that could impair safety have to be eliminated immediately.

2.2 Intended use

The mobile processing shredder is built exclusively for shredding organic material and should be used for that only.

Any use beyond this will be considered as not in accordance with the intended use.

The Producer, J. WILLIBALD GmbH, does not assume any liability for damages resulting from it whatsoever

The risk is taking upon exclusively the operator.

Intended use also means and includes observance of all information contained in this operation manual and due compliance with all inspection works and service routines as prescribed herein.

Unauthorized modifications of the machine exclude liability for any resulting property damage and personal injury.



DANGER

Not intending use danger.

Any use beyond intended use is considered as not in accordance with the intended use and / or other use of the machine, resulting in dangerous situations, and it extinguished operating permit.

The machine should be used as intended only.

The wheel drive must be used on even ground only. Any use beyond that is considered as not in accordance with the intended use. The producer cannot be held liable for damages resulting from any such improper use.

The wheel drive is no substitute the parking brake!

CAUTION



Danger of inappropriate use

Inappropriate use of the EP 5500 Shark may cause bigger damages to the machine and may also affect safety devices and protective gear to the result that the operator's personal safety can no longer be guaranteed.

In particular, the EP 5500 Shark must not be used for the following operations:

- The shredding of rubbish from construction sites and ceramic wastes;
- The shredding of metal scrap and other metal parts;
- The shredding of ceramic scrap.

2.3 Working place

Using area

The machine EP 5500 Shark can be used for the processing of bulky coarse wood (wood packaging, wood, garbage, industrial waste wood, building demolition wood) as a basis for operating biomass cogeneration plants and for the crushing of green waste for composting.

The large volumes material can be crushed on the spot.

Destination

There is the processing of large volumes of raw material savings energy in the shortest possible time.

Operator

The machine is operated by one operator who loads (fills) the machine at the same time.

The machine must be operated in compliance with the instructions by trained personnel who are at least 18 years old.

In order to start or stop the machine, the operator must approach it and go away from it by passing through the zone shown in illustration 2.2 above.

Illustration 2.2
EP 5500 Shark
Danger zones

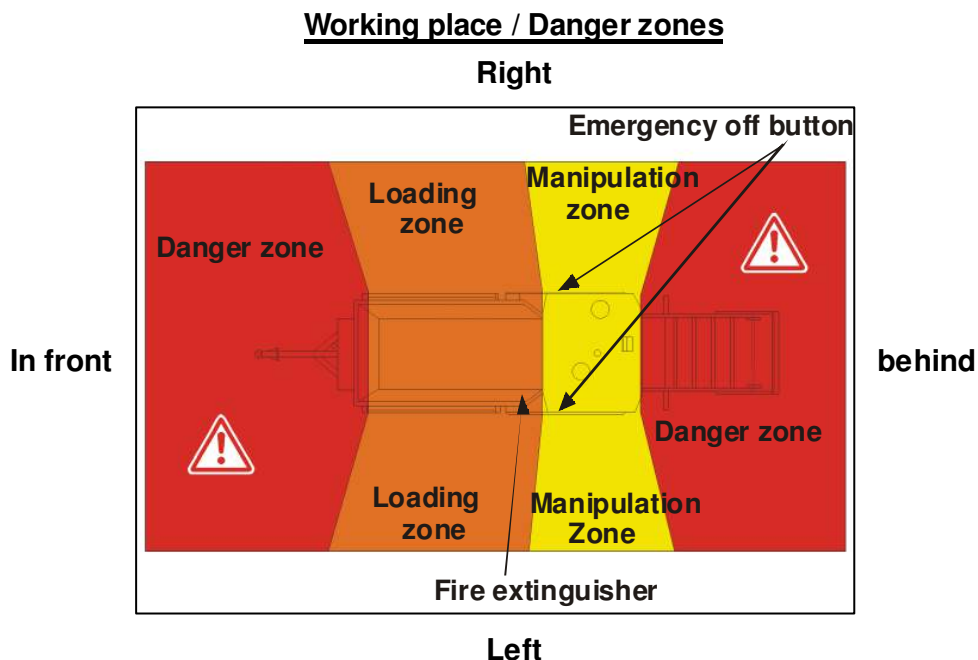

Method

The operation of the EP 5500 Shark is carried out by control cabinet or remote control. Optical function and fault of the central cabinet comply with the latest safety regulations.

All important functions can be easily operated via remote control from the user.

NOTICE

- The machine can run on even ground under constant observation only. Secure a large enough environment so that no hazard may arise from defective or faulty radio communication system!
- In an emergency, use the emergency stop switch on the machine!
- The control cabinet is to hold necessarily closed on account of the ingress of moisture and dust.
- The surface of the keyboard is sensitive to sharp objects. The buttons must be pressed with the finger with gentle pressure only.
- The remote control is so stored, that unauthorized or others use is excluded. This is particularly true during operating the machine.

2.4 Technical characteristics

Illustration 2.3
EP 5500 Shark
Side view

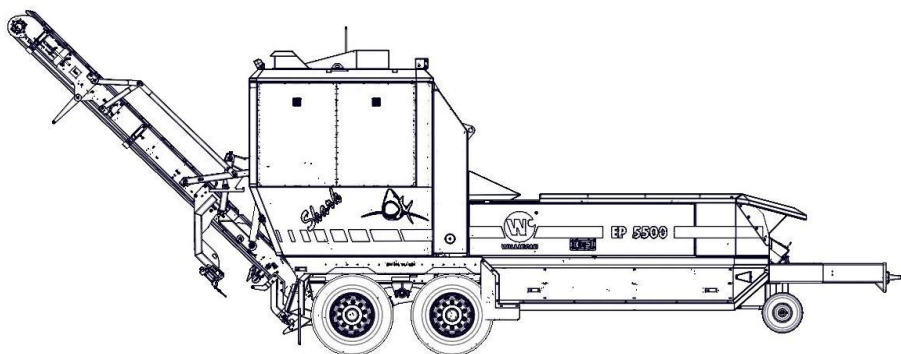

Driving speed:	**max 80 km/h with antilocking system
min. trailer load at traction vehicle.:	**> 18000 kg
min. trailer support load at traction vehicle	**> 1000 kg
Throughput:	
- green waste	up to 220 m ³ /h
- wood waste	up to 130 m ³ /h
- pre-shredded wood waste	up to 210 m ³ /h
- bark	up to 230 m ³ /h
Feed opening	
- Wight	1450 mm
- Height	900 mm
Height of loading	2200 mm
Height of transfer	3,5 m (optional 4,5)
Dimensions:	
Transport position (LxWxH)	9.950x2.500x3.950 mm
Work position (LxWxH)	11.750x2.500x4.500 mm
Weight:	**max. 19000 kg
Electrical system:	24 V
Battery:	2 lead accumulators 12 V / 135 Ah
Number of axes:	2 (tandem type)
Brake system:	2 circuit compressed air brake
Motor power EP 5500 Shark	352 kW / 480 PS 382 kW / 520 PS
Rotor r.p.m.	1200 min ⁻¹
Number of flails:	48 / 40 / 32
Fuel tank:	500 l Diesel normal operation time
Hydraulic tank:	330 l hydraulic oil
Antifreeze:	up to -25° C, factory side
** Sizes and weights vary depending on standard equipment and accessories	

2.5 Equipment

Standard version of a mobile processing shredder:

Base frame with running gear, spring born twin axle for drive speeds up to 80 km/h, pneumatic brake system, 385/65 R22.5 tire equipment, endless floor with cleaning worm, top mounted built-on motor, rotor driven via power belts, flail shaft on option either equipped with 48 freely swinging flails, power connection via hydraulically operated tension roller, counter blades for optimal defibration of the material process, a hydraulically driven self-cleaning draw-in roller, a complete hydraulic system including 330 l oil tank, load depending automatic regulation of both endless floor and draw-in roller, wheel chock, lighting installation in compliance with StVZO (German Regulations Authorizing the Use of Vehicles for Road Traffic), equipped with a 4 kg fire extinguisher (ABC), lacquering: RAL 6018.

* Additional equipment:

- Discharge conveyor;
- Antiskid system;
- Radio control;
- Wheel drive;
- Central lubrication;
- Reversible fan;
- Acoustic insulation for motor;
- Hydraulic feed-hopper extension;
- Hydraulic folding tail-board increase;
- Hydraulic front wheel;
- Additional fuel tank;
- Working light;
- Crawler track type chassis;
- Magnetic separator;
- Hydraulic axle extractor;
- Particle filters.

Designations applied at the machine

Designations, such as type plate and machine no. have been applied right side of the machine at the drawbar, CE sign is on the left side of shredding units above control cabinet.

* Discharge conveyor

The discharge conveyor allows forming up compost windrow heaps of up to 3,5 m height to the advantage of higher working safety in the discharge area as well as to the advantage of it is the loose stratification of the shredded materials, thus enabling make up higher heaps.

* Anti-skid system

The anti-skid system is prescribed with machines over 10 tons for driving speed of up to 80 km/h. However no anti-skid system is necessary for permission to 60 km/h.

* Remote (radio) control

The remote (radio) control enables to operate the control panel partially from a distance, so that there is no need to access the machine directly. The functions that can be remote controlled are: stop, control of the draw-in rollers, the heavy duty floor conveyor (endless floor), discharge belt and motor r.p.m. as well as the non-locking functions such as wheel drive and reshredding control etc.

* Wheel drive (Driving forward device)

By wheel drive of an advance EP 5500 Shark on a level and firm ground with a tractor is unnecessary. (The machine can drive automatically (radio)). This has the advantage of continuous filling.

The wheel drive is no substitute the parking brake!

* Automatic central lubrication system

The connected lubrication points are lubricated in preset intervals while the machine is on duty.

* Reversible fan

The direction of rotation of the fans of the main condenser and oil cooler will be reversed by controlling for a short time automatically. This option is used to clean the grille, and also to protect the machine from overheating.

* Acoustic insulation for motor

The sound pressure level produced by the machine exceeds 83 dB (A). For the sound insulation of the motor compartment of the machine the inside of the hood in the engine room were provided with insulation material.

* **Hydraulic folding tail-board increase;**

The hydraulic hopper extends filling tub of the machine and is practical for bulky raw material.

* **Tail-board increase**

The tail-board increase increases the loading area of filling tub.

* **Hydraulic front wheel**

The front wheel on the drawbar is used to keep the machine at standstill and disengaged in balance. As a standard design the front wheel can raise and lower by turning the crank manually.

The hydraulic front wheel moves over the radio remote control.

* **Additional fuel tank**

The tank that is used in addition to the main tank of the machine, serves to increase the range or the duration of use.

* **Working light**

With the work lights, which are in the middle of the hood, the loading area of the machine is illuminated.

* **Crawler track type chassis**

By crawler track is the weight of the vehicle to a larger area distributes and reduces the pressure on the ground. The contact area is increased significantly and captured more points of contact on uneven ground. The total off-road capability is greatly increased.

* **Magnetic separator**

The magnetic drum separator is a sorter pieces of metal from the processed wood material. The separation effect is that it is magnetizable substances are attracted by the magnetic roller and are then collected in the separator.

* **Hydraulic axle extractor**

Each machine is equipped with a mechanical axle extractor. The hydraulic shaft extractor is used for faster and easier tool changes.

* **Particle filter**

The filter is designed for the cleaning of the motor exhaust gases from diesel and internal combustion motors. The diesel particulate filter is inserted in place of the silencer in the exhaust pipe.

EC-Declaration of Conformity

Within the meaning the EC Machinery Directive 2006/42 EC, Annex II A

We here confirm that the following machine

Designation of machine: Mobile Processing Shredder

Type designation: EP 5500 Shark

Machine no.:

Manufacturer: J. Willibald GmbH, D - 88639 - Wald – Sentenhart

due to designing and make and the type version marketed by our company meets with the basic and relevant safety and health requirements as specified and set forth in the corresponding EC Directives.

EC directives to be complied with:

- | | | |
|-------------------------------------|--|-------------|
| <input checked="" type="checkbox"/> | EC- Machinery Directive | 2006/42 EC |
| <input checked="" type="checkbox"/> | EC-Low-Voltage Directive | 2006/95 EC |
| <input checked="" type="checkbox"/> | EMC Directive | 2004/108 EC |
| <input checked="" type="checkbox"/> | EC-Directive on polluting noise emissions of to use in the free one of planned device and machines | 2000/14 EC |
| <input checked="" type="checkbox"/> | EC-Directive on the brake systems of specific vehicle classes and their trailers | 98/12 EC |
| <input checked="" type="checkbox"/> | EC-Directive regarding the harmonization fh the legislative provisions enacted by the Community Member States on measures to be taken to control the emission of aggressive gasiform substances and air-pollutant particles originating from combustion engines used to power mobile equipment an machines | 2006/105 EG |

The following harmonized standards have been applied:

- | | | | | | | | |
|-------------------------------------|----------------|-------------------------------------|----------------|-------------------------------------|--------------|-------------------------------------|--------------|
| <input checked="" type="checkbox"/> | DIN EN 12100 | <input checked="" type="checkbox"/> | DIN EN 349 | <input checked="" type="checkbox"/> | DIN EN 953 | <input checked="" type="checkbox"/> | DIN EN 4413 |
| <input checked="" type="checkbox"/> | DIN EN 13849-1 | <input checked="" type="checkbox"/> | DIN EN 13849-2 | <input checked="" type="checkbox"/> | DIN EN 13857 | <input checked="" type="checkbox"/> | DIN EN 13850 |
| <input checked="" type="checkbox"/> | DIN EN 14119 | <input checked="" type="checkbox"/> | EN 60204-1 | <input checked="" type="checkbox"/> | DIN EN 620 | <input checked="" type="checkbox"/> | DIN EN 13525 |
| <input checked="" type="checkbox"/> | DIN EN 13683 | | | | | | |

This declaration of conformity becomes invalid if the machine or parts of the machines are changed or altered without our previous agreement and consent.

A complete technical documentation is available and at hand. The machine related operating instructions are available and hand:

- | | | | |
|-------------------------------------|---------------------------|-------------------------------------|---|
| <input checked="" type="checkbox"/> | in their original version | <input checked="" type="checkbox"/> | as version translated into the user`s native language |
|-------------------------------------|---------------------------|-------------------------------------|---|

Person authorized to compile the technical file:

A. Willibald

J. Willibald GmbH, Maschinenfabrik, Bahnhofstraße 6, D-88639 Wald- Sentenhart

Manufacturer:

J. Willibald GmbH, Maschinenfabrik, Bahnhofstraße 6, D-88639 Wald- Sentenhart

Place, Date, Signatur

J. Willibald -Managing Director-

A. Willibald - Managing Director-

3.0 SAFETY PRESCRIPTIONS

3.1 Personnel requirements

3.1.1 Skills

In the operating manual the following skills for various activities are identified:

- **Trained staff** is a person who was in a teaching via its assigned tasks and potential hazards of improper behaviour taught.
- **Professional staff** is a person who is due to their specialized training, knowledge and experience and knowledge of the relevant provisions in a position to carry out the tasks entrusted to professional standards.
- **Electrician specialist staff** is a person who is due to their specialized training, knowledge and experience and knowledge of relevant standards and regulations in a position to carry out work on electrical systems, identify and avoid potential hazards.
- **The electrician specialist staff** is responsible for the specified application spot in which it operates, trained and familiar with the relevant standards and regulations.
- **Operating personnel** is the person who is responsible for installing, operating, adjusting, maintaining, cleaning, repairing or transporting machinery.

3.1.2 Training of personnel

WARNING



Danger for unauthorized

- Unauthorized persons do not meet the requirements described here do not know the dangers in the work area.
- The trained and qualified personnel may work on the machine only.
- The responsibilities of the staff should be clearly indicated for the installation, commissioning, operation, maintenance and repair.
- The apprentice personnel must be trained under the supervision of an experienced person on the machine.

3.1.3 Personal protective equipment

At work is the wear of personal protective equipment required to minimize health hazards.

- The required personal protective equipment must be provided by the operator.
- All safety equipment must be checked regularly.
- You must to wear always the necessary personal protective equipment by each operation.
- Comply in the work area existing labels for personal protective equipment.



Helmet

to protect against falling and flying parts.



Protective goggles

to protect the eyes from flying parts.



Hearing Protection

to protect against hearing loss by noise



This label is affixed to both sides of the machine.

Description: take during working the safety helmet, safety glasses and ear protection.



Safety Gloves

There are to protect the hands from friction, scraping, punctures or deep injuries and to protect from hot or caustic parts or fluids.

3.1.4 Informal safety measures

- This operation manual must permanently be kept and be at hand at the place of operation of the machine;
- Present operation manual and all prescriptions contained herein are supplemented by generally operative and local regulations in regard to accident prevention and to environmental protection. These too must be made available and complied with;
- All safety information and warnings applied at the machine must be kept in always legible condition.

3.1.4.1 Symbols and markings on the machine

- These symbols, information signs, pictograms, warning and mandatory signs are stickers with information about the handling of the machine. They are for your safety and must be heeded!!
- Ensure that the signs are always legible. In case of damage or loss, the signs must be replaced immediately!

3.1.4.2 Overview labels and warning signs

Pos	Designation	Quantity	Willibald-N
1	Attention trap-door!	2	199-01-126
2	Never walk on the loading area when the motor is on!	2	199-01-127
3	Attention rotating parts!	2	199-01-128
4	Never open or remove safety devices with running motor.	1	199-01-129
5	Never reach into the crushing danger area as long as parts may move.	2	199-01-704
6	Obstacle above, danger place!	2	199-01-705
7	Warning of fire hazard! Read before commissioning instructions and safety information!	1	199-01-275
8	Warning of fire! Fire, naked flame and smoking are banned!	1	199-01-276
9	Attention corrosive material AdBlue!	1	199-01-698
10	Attention Magnet!	2	199-01-130
11	Take during working the safety helmet, safety glasses and ear protection!	2	199-01-139
12	Fire extinguisher	1	199-00-019
13	Prior to any repair, maintenance or cleaning work make sure the engine and main battery switch are in "OFF" position!	1	199-01-132
14	CE-sign	1	665-81-017
15	Machines Quick Guide for Willibald - Shredder	1	199-01-239
16	Direction sign "Grease gun "	1	199-01-193
17	Attention! Grease nipple	1	199-01-306
18	Direction sign "Ladder"	5	199-01-161
19	Direction sign "Diesel fuel only"	2	199-01-159
20	Direction sign "Tire pressure"	4	199-01-136
21	Direction sign "Hydraulic pump level"	1	199-01-167
22	Direction sign "Retighten bolts"	1	199-01-149
23	Direction sign "Battery main switch"	1	199-01-157
24	Attention! "Hood protection!"	1	199-01-156
25	Direction sign "Close hood"	1	199-01-155
26	Attention! Maintenance position Danger!	1	199-01-532
27	Attention! Discharge conveyor protection!	1	199-01-563
28	Functions of the hand pump	1	199-01-611
29	Hydraulic flailshaft extractor	1	199-01-209
30	3-way valve position: Crushing flap/ flail shaft extractor	1	199-01-328
31	Direction sign: Hood lift/lower via Motor/ Hand pump	1	199-01-558

3.1.4.3 Illustration labels and warning signs

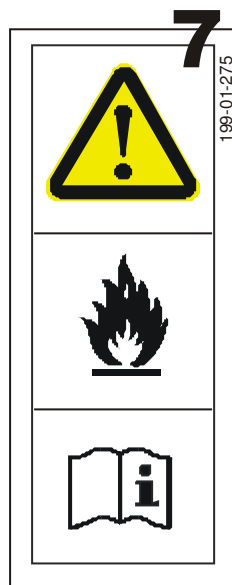
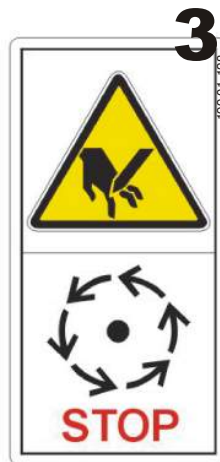

13



Prior to any repair, maintenance or cleaning work make sure the engine is switched off. Main battery switch must be in "OFF" position.

Engage clutch only when engine is running at low speed.

Before initial operation read operating and safety information carefully.

Use operating supplies in accordance with the manufacturer's information.

199-01-132

14



15

Abbreviated Operating Instructions for Willibald Shredder Type

Safety:

- Never climb on a running machine.
- Danger zones during shredding: at front and rear in the longitudinal direction may be thrown from the machine, and in the area where loading takes place.
- Do not start the engine when safety devices are open.
- Provide additional mechanical support for the engine hood when open.
- Observe the following when accessing the shredder rotor: do not access until the rotor has come to a complete standstill (control for several minutes after start-down), provide support for the feed roller if accessed at the feed side (MZA), or secure with lock pins (type SR).
- Observe separate warning label when disengaging the discharge belt (by means of lifting device for MZA and with support legs for SP).
- See notices on wheel blocks on shipping terms.
- Do not remove any safety devices. No technical modifications may be carried out without the previous consent of WILLIBALD.
- Respiratory protection masks must be worn in accordance with national regulations when the machine is in operation.

Placing the Shredder into Service:

- Align the machine to the feed.
- Turn the main switch to the ON position.
- Turn the ignition key to the START position.
- Start engine.
- Press the adjust driving unit position.
- Engage the rotor clutch only when the engine is idling, and then wait until power transmission has been fully established.
- Apply full throttle to the engine.
- Switch discharge belt to forward.
- Switch feed roller to forward.
- Switch floor conveyor to forward.
- Switch on radio remote control (green lamp at the panel lights on).

Material Feed and Machine Operation:

- Radio remote control must always be in possession of the operator.
- Ignore run warning for foreign objects prior to loading, if necessary by dumping the first bucket loads onto the ground.
- Assure uniform loading to the shredder and avoid overloading.
- Increased loading is indicated by frequent change in direction of floor conveyor and feed roller.

Shutting the Shredder Down:

- Switch off the floor conveyor.
- Switch off the feed roller.
- Switch off the discharge belt.
- Set engine to idle.
- Allow engine to run for at least 2 minutes at idle, then disengage the clutch.
- Disengage the wheel driving unit.
- Switch the engine off.
- Turn the ignition key to the OFF position.
- Turn the main switch to the OFF position.

Routine Maintenance

Daily:

- For machines with central lubrication: Check oil level at lubricant reservoir or manually lubricate V-belt pulley at engine twice a day (one full stroke with grease gun).
- For machines without central lubrication: Lubricate bearings, shredder rotor, floor conveyor, feed roller and discharge belt at both sides.
- Inspect Condition of rotor shaving tools and scrapers. Multiple V-belts to rotor, 18 levels for hydraulic oil, and coolant water, as well as contamination level of engine oil filter, engine and hydraulic system radiators and hydraulic system breeder valves.
- Remove dust, oil and contamination at least from the hot press the exhaust system and turbocharger.
- Clean the underside of the machine.

Weekly:

- Discharge condensate from compressed air brake cylinder.
- Inspect and lubricate drive chain at feed roller (MZA machines only).
- Lubricate wheel driving unit at both sides.
- Grease tension pulley for power band (one full stroke with grease gun).
- Inspect condition and tension of chain at discharge belt, as well as tightness of screws.
- Inspect condition of rotor and supporting sub-frames.
- Clean machine both inside and out.

Monthly:

- Lubricate vehicle support crank.
- Check oil level for feed roller transmission, floor conveyor and wheel driving unit.
- Check transmission of level and condition of the conveyor at the discharge belt, as well as magnetic separator drum.
- Lubricate suspension and brake lever at drive axes.
- Check tension of floor conveyor.
- Check rear-end lights.

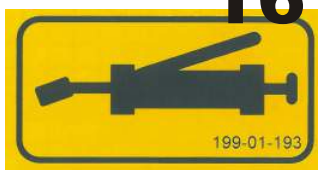
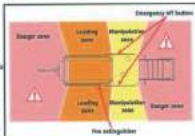

199-01-193

17

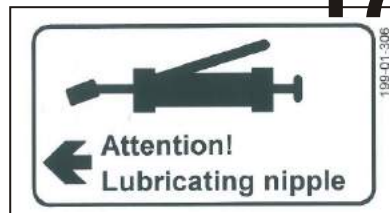

199-01-306

18



199-01-161

19



199-01-159

20



199-01-136

21

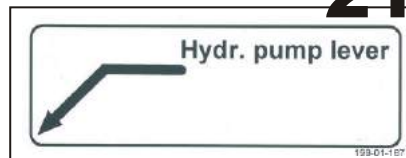

199-01-07

22

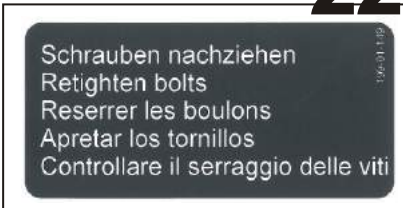

199-01-159

23

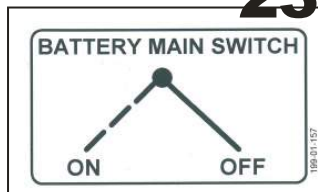

199-01-157

24



199-01-156

25

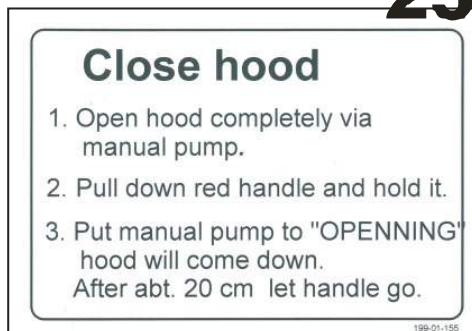

199-01-155

26



27

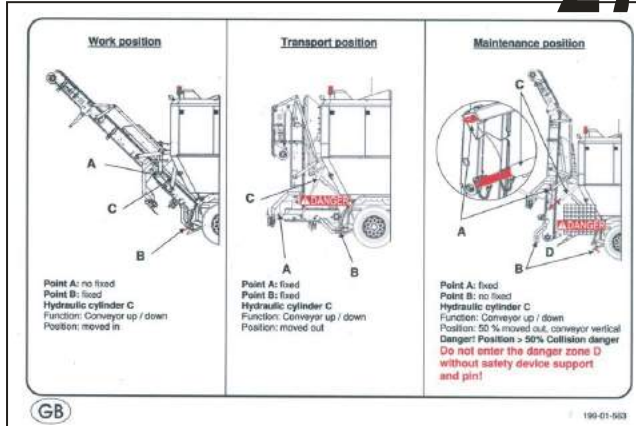

28

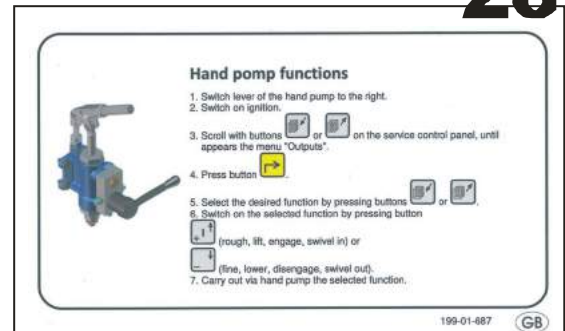

29



30



31

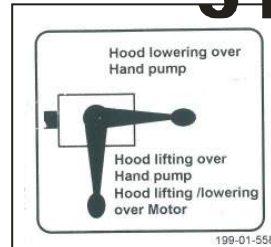

3.1.4.5 Position labels and warning signs



6 18 12 21 23 7 2 13 14



23 7 2 13 20 14 15



23 13 20 14 11 26 27 10 1



8 19

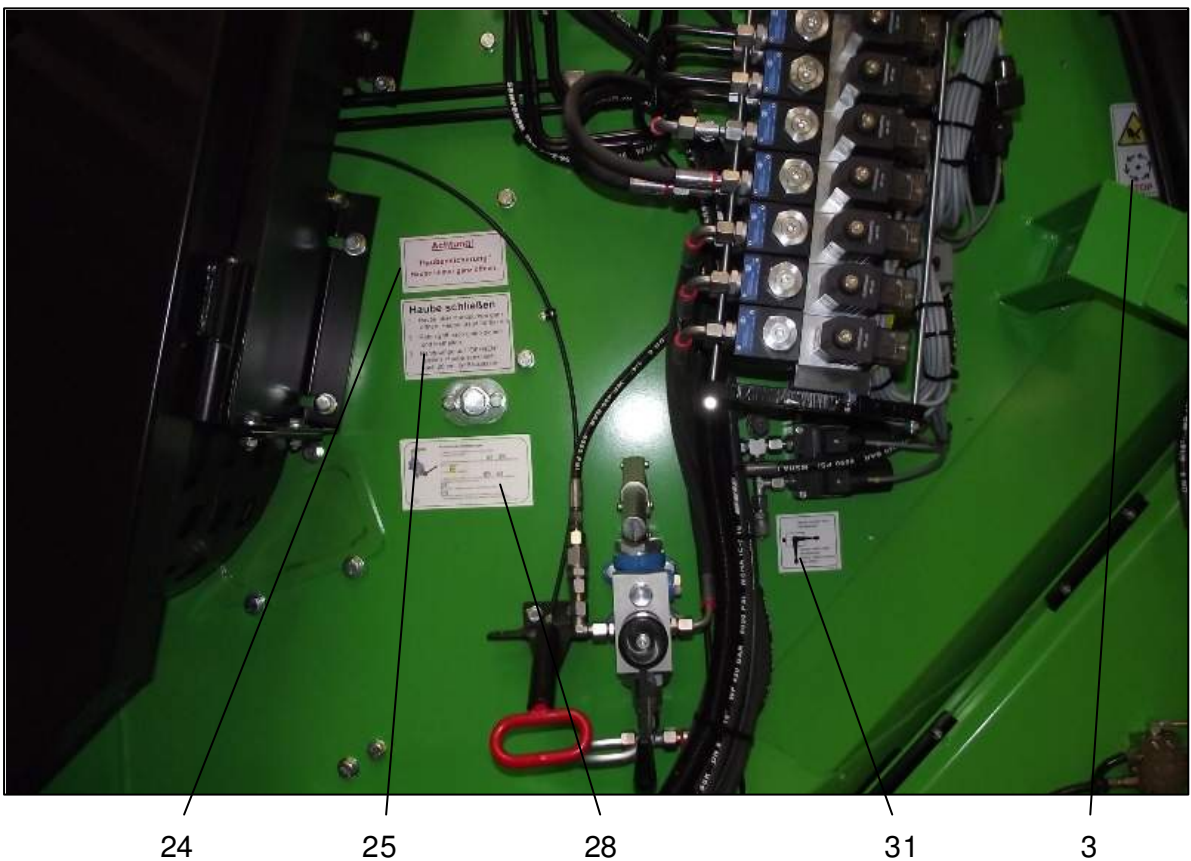

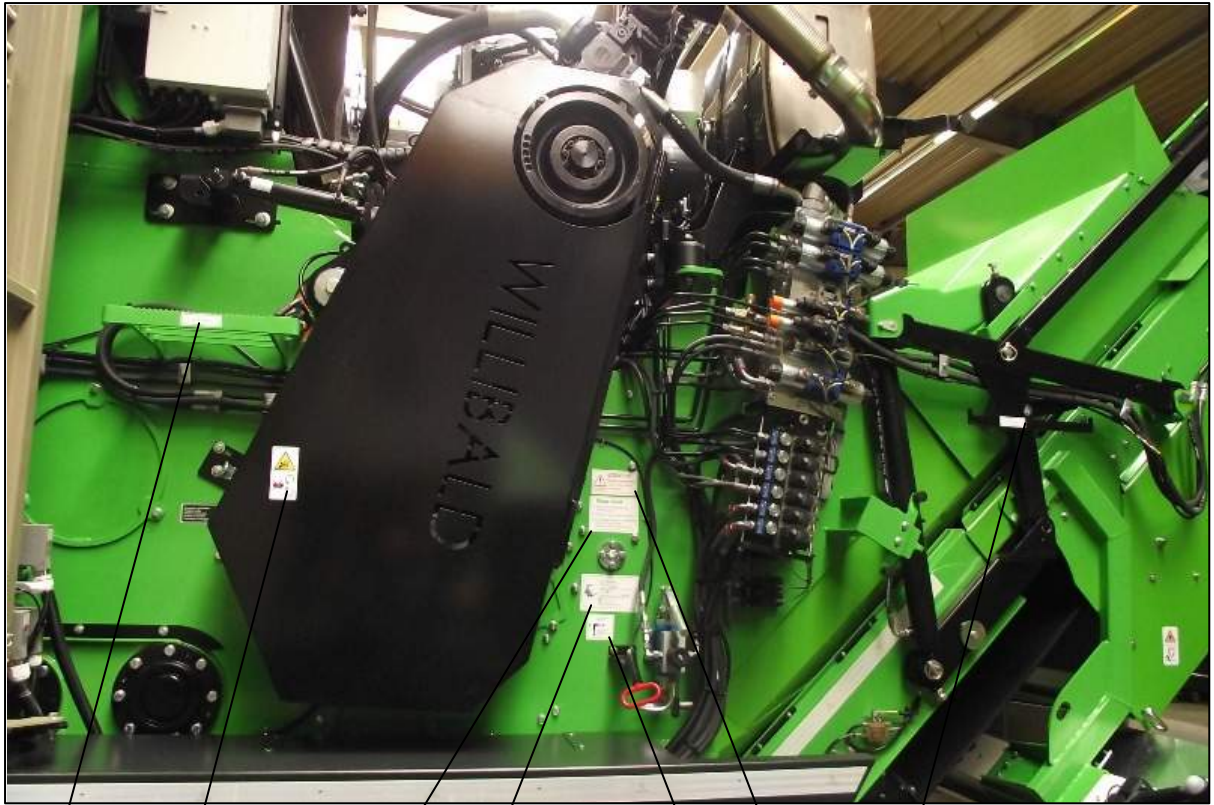

18 4 25 28 31 24 18



18 9 18 16 29 30 22 17

3.2 SAFETY INFORMATION and potential dangers in the use of the machine

3.2.1 Protective devices



WARNING

Danger of non-functioning protective devices

- Emergency stop device must be always freely accessible;
- Make sure and control each time before actuation of the machine that all safety devices and protective gear are mounted properly and operative;
- Safety devices and protective gear mounted at the machine may only be removed after complete standstill and only if the machine has been protected against restart;
- In case of delivery of part components, the operator is responsible too that safety devices or protective gear will be mounted and installed as prescribed.

3.2.2 Safety precautions to be observed during normal duty

- Operate the machine only if sure that all safety devices and protective gear are fully operative;
- Before activation of the machine, make sure that nobody can be injured or endangered by the starting machine;
- Control the machine at least once per shift for visible damages at the outside and check for functionality of safety devices and protective gear.

3.2.3 Machine control

NOTICE



Danger of property damage due to incorrect handling of the control

- The control cabinet must be kept locked at all times.
- Instructed personnel are authorized to operate the machine control only.

3.2.4 EMERGENCY STOP device

The emergency stop device is connected so that during interruption of power supply, or the activation energy supply after an interruption, dangerous situations for persons and property are excluded.

Emergency stop device must be always freely accessible.



WARNING

Danger of non-functioning safety devices

Safety devices ensure maximum safety during operation. Safety devices must not be overridden when work processes will complicate due to safety devices. The security is guaranteed when safety devices are intact only.

- Checks before starting work, all safety devices are installed properly and functional.
- Checks before starting the motor, all safety devices are installed properly and functional.

Two stop buttons are mounted on the machine. If one of those, or the one on the control, will get pushed in, the engine will Stop immediately. The activated stop button will stay engaged until it will get unlocked through a clockwise rotation under tension.

*Illustration 3.1
EP 5500 Shark
Emergency off button*

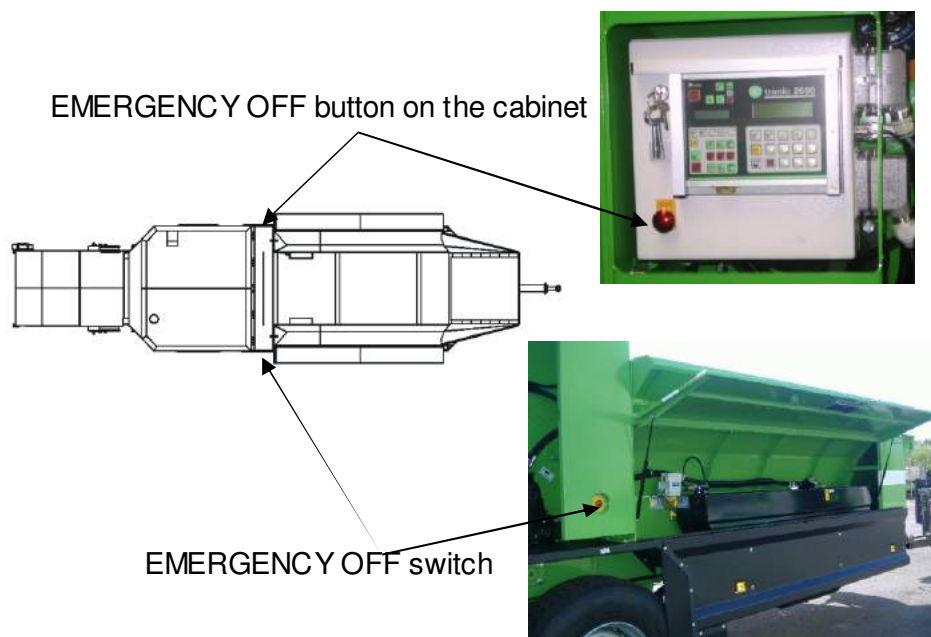



3.2.5 Dangers caused by electric energy

DANGER

Danger due to electrical current

In case of contact with live parts is immediate danger to life.
Damage the insulation or components can be fatal.

- All works on the electric system must be performed by an expert electrician only;
- Check the electric equipment of the machine regularly.
- Immediately repair and eliminate loose connections and/or cables that are charred through;
- Make sure the switch cabinet is always kept closed. Access is allowed to authorized personnel only;
- In case works on voltage carrying parts or components of the machine need to be performed, provide for a second person's presence that can turn the main switch off in case an emergency situation occurs;
- Before performing any maintenance, cleaning and repair work, switch off power supply and secure against restart.

3.2.6 Dangers caused by hydraulic energy

WARNING



Dangers caused by hydraulic energy

The hydraulic energy can cause serious or even fatal injuries.
Hydraulically driven components can move unexpectedly.
Due to damage of individual components, hydraulic fluid can leak under high pressure.

- Only specially skilled and experienced personnel familiar with it may work on the hydraulic systems of the machine;
- Before performing any repair works, get free the pressurized system sections and pressure lines that have to be opened for these works;
- Replace hydraulic hoses in appropriate intervals, even if no safety relevant deficiencies can be detected.

3.2.7 Passing out of noxious steams and gases



WARNING

Danger of escape of hazardous gases and vapors

The machine is equipped with a diesel engine that can be emitted during operation of the harmful gases and vapors. The integrated exhaust and filter system prevents at normal use of the machine the escape of harmful substances and gases, and ensure compliance with legal limits.

- Mobile shredding units with Diesel generators must not be operated in closed rooms.

3.2.8 Noise level produced by the machine

WARNING



Hearing damage from noise

The sound pressure level produced by the machine exceeds 83 dB (A). Depending on the local operation conditions, a noise pressure level may be produced that can cause noise deafness.

- The operation personnel must in both cases be protected by corresponding safety equipment or safety measures.



3.2.9 Service and maintenance, elimination of faults

WARNING



Danger of injury due improperly performed maintenance, inspection and repair work!

Before performing any service routines, inspection or repair works, make sure the machine is completely off circuit (Illustration 3.2) and the main switch of the machine has been protected against unintentional restart.

Illustration 3.2
EP 5500 Shark
Main battery switch

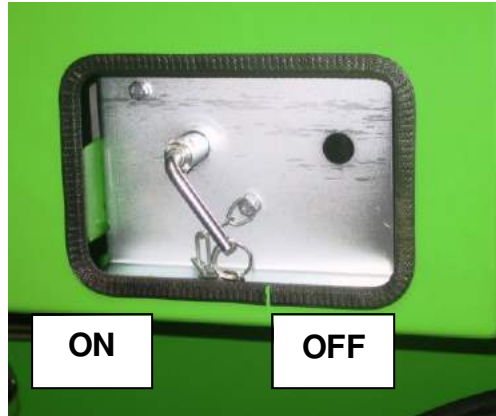
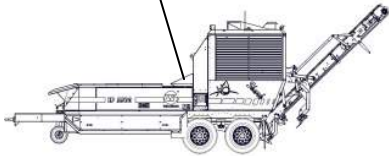

- * Main switch must be in "OFF" ("AUS") position
- * Attach a warning sign to warn of the dangers of a restart

- All maintenance operations are carried out in accordance with maintenance schedule;
- Compliance with all time intervals or reaching a certain number of operating hours.;
- Take prescribed attitude, maintenance and inspection work punctually and register into the list on the page 126,
- Inform the service personnel before beginning of the maintenance,
- Secure against unintentional start-up all components and operating media such as compressed air and hydraulics,
- Mount and save carefully with lifting witnesses the larger building groups by the exchange,
- Control the solved bolt connections for tightness,
- After completion of the maintenance works or service routines, check all safety devices and protective gear for proper functioning.

3.2.10 Constructional modification of machine

- Never modify the machine or mount any attachments whatsoever without the manufacturer's prior consent. Same also applies for any welding performed on load carrying parts of the machine;
- All modifications whichever are subject to prior written consent by the company J. WILLIBALD GmbH;
- Any machine parts found being not in perfect condition must be replaced immediately;
- Use Willibald-original spare and wear parts only.

Only our approved original spare parts are checked by us and thus have the suitable conditions for the use of the machine. Third-party components is not guaranteed that they are designed to load and safety requirements and manufactured.



WARNING

Danger of injury by improper replacement parts

Incorrect or faulty spare parts can cause damage, malfunction or failure and impair safety.

- Use Willibald-original spare and wear parts only.



NOTICE

Give in all messages and inquiries the machine chassis number.
Order replacement parts by dealers or direct from WILLIBALD.

3.2.11 Cleaning of machine and disposal

Regular cleaning is a basic condition to the preservation of service life and functional capability of the machine. Use approved cleaning agents only.

The cleaning agents must be coordinated with the appropriate material, which should be examined before starting work. The corrosion protection should not attack parts. In general, acids and crude detergent, and solvent-based cleaners are unsuitable and can cause irreparable damage.

To clean should find as possible wetting agent solution with a pH 5-8. Ask the manufacturer in case of doubt on the suitability of the cleaning agent.

All media, stuff and materials must be applied, handled and disposed in the appropriate manner, which particularly applies in regard to

- any works performed on greasing systems and lubrication contrivances
- Cleaning agents used for cleaning purposes,

3.3 WARNINGS and special dangers in the use of the machine

3.3.1 Fire hazard in motor compartment



Highly flammable materials - diesel fuel, oils and fats

WARNING

Fire hazard due to highly flammable materials!

Pieces of wood and wood dust are inflammable!

Fuel and hydraulic fluid are inflammable!

Dirt accumulations in the motor compartment may lead to the break-out of a fire.

- Check the Motor compartment regularly for the accumulation of dirt and other dangerous contaminators. If need be, but at least once every day, clean it using compressed air.
- Before each motor start-up, both the fuel- and the hydraulic system must be checked for damages and/or leakages.
- If the fuel- and/or hydraulic system have incurred damages or leaks, repair and eliminate these defects.
- Pieces of wood, wood chips and dust as well as all other substances of a combustible nature must be removed by all means!
- Cleaning is permitted with the switched off motor only.

This label is located on the left side of the machine in the direction of travel, above the control cabinet:

Description: Warning of fire hazard! Read before commissioning instructions and safety information.

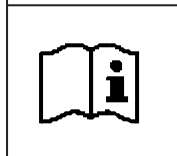

3.3.2 Fire hazard by replenishing with fuel

WARNING

Fire hazard due to highly flammable materials!

Smoking and naked flames forbidden!

Fuel is inflammable!

- Do not smoke while handling with fuel. Always make sure that nobody is smoking in the vicinity or handles with open fire.
- Replenishing is admitted with the motor in stopped condition only.

This label is located on the diesel fuel tank.

Description: Warning of fire! Fire, naked flame and smoking are banned!



3.3.3 Damage resulting from crystallized reducing agent AdBlue (Carbamide)

NOTICE

Component damage resulting from crystallized carbamide

The reducing agent AdBlue is a non-combustible, colorless-and odorless, water-soluble fluid. The freezing point lies at -11 °C.

Adblue is classified as non-dangerous.

The reducing agent crystallizes on drying.

On non-stainless steels and non-ferrous heavy metals AdBlue has a strongly corrosive effect (triggering rust).

- The reducing agent must be immediately washed from metallic surfaces (sheet and aluminum, and also painted) with clear, hot water.
- All components, which come into contact with carbamide, must be immediately rinsed in hot water after disassembly and dried with compressed air.

This label is located on the carbamide tank.

Description: Attention corrosive material AdBlue!



CAUTION

Irritation of skin and eyes

Contact with AdBlue can cause despite all precaution an accident.

- Reducing agent must not be allowed to come into contact with the skin, eyes or clothing.
- Change the filter when wearing protective gloves and protective eyewear only.

With high temperatures in the tank (over approx. 50°C, e.g. due to direct sunlight) the reducing agent decomposes. This can lead to the generation of ammonia vapor (pungent smell).

- Do not inhale this vapour.



3.3.4 Danger due to strong magnetic fields



WARNING

Danger to life due to strong magnetic field in machines with magnetic metal separators

The EP 5500 Shark can be constructed with the metal separator with magnet roller as an option.

Strong magnetic fields can cause serious injury or death, as well as considerable property damage.

- People with pacemakers should not be in the vicinity of the metal separator. The function of the pacemaker could be affected.
- People with metal implants should not be in the vicinity of the metal separator. Implants can heat up or be attracted.



This label is located on both sides of the machine when the machine is equipped with metal separator.

Description: Attention Magnet!

3.3.5 Dangers due to hot surface or liquid



CAUTION

Risk of burns from hot surface or liquid

Contact with hot components can cause burns.

- Always wear protective clothing and gloves when working near hot components
- Prior to working to ensure that all components have cooled to ambient temperature.

3.3.6 Danger by filling the machine

CAUTION



Danger caused from flying parts at filling the machine.

The EP 5500 Shark cannot be filled by hand!

Falling back material can cause injuries

- Use for the filling of the machine a tractor or loader.

WARNING



Drawing-in danger across moving endless floor and rotating in-feed roll

The EP 5500 Shark should not be entered to fill!

Movable endless floor on top and bottom side and rotating in-feed roll can cause serious injury.

- Make sure nobody stays within the danger zone (Illustration 2.2, Danger zones) of the EP 5500 Shark except operator with tractor or loader when starting the motor!
- Make sure that nobody can succeed into the danger area of the EP 5500 Shark except operator with tractor or loader when the machine is running!
- Use for the filling of the machine a tractor or loader.



This label is located on the both side of the machine.

Description: Never walk on the loading area when the motor is on!



This label is located on the both side of the machine.

Description:

Never walk on the loading area when the motor is on!

Obstacle above, danger place!

3.3.7 Danger by hydraulic feed-hopper

WARNING



Crushing hazard in area of hydraulic feed-hopper!

The hydraulic hopper in the filling trough may cause the pivoting movements or on failure of hydraulic serious injury.

- Make sure nobody stays within the danger zone (Illustration 2.2, Danger zones) of the EP 5500 Shark when starting the motor!
- Make sure that nobody can succeed into the danger area of the EP 5500 Shark when the machine is running!



This label is located on the both side of the machine.

Description: Never reach into the crushing danger area as long as parts may move.

3.3.8 Danger by discharge conveyor

DANGER

Crushing hazard in area of discharge conveyor Danger of injury due moving discharge conveyor

Linearly moving parts can cause serious injury.

- During operation, no moving parts to interfere or tamper with moving parts.
- Make sure nobody stays within the danger zone (Illustration 2.2, Danger zones) of the EP 5500 Shark when starting the motor!
- Make sure that nobody can succeed into the danger area of the EP 5500 Shark when the machine is running!

This label is located on the left side of the machine

Description: Attention trap-door! Do not stand in the swing area of devices!



3.3.9 Danger due rotating rotor



DANGER

Danger due rotating rotor!

The rotor will be running for several minutes after switching off the motor, and all dangers existing, when the motor is running will last on!

- Do not come into the draw-in and discharge area of the EP 5500 Shark!
- Before starting the motor makes sure that there is no person between the rotor and discharge conveyor.

This label is located on the left side of the machine

Description: Attention rotating parts! Machine parts can be touching when they are stopped completely only.

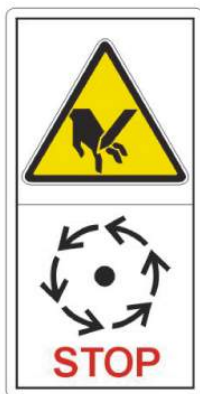

3.3.10 Danger due rotating idler roll and power belt

DANGER

Drawing-in danger and crushing hazard due rotating idler roll and Power belt!

The drive motor brings the rotor in motion and the rotor rotates at very high speed, 1200 min⁻¹. Therefore, the pulley and power belts are protected with a fixed fairing.

No care these suggestions can have duty effects of health, till vital wound with and without death result.

- The motor must never be started, until on all protect parts for the power belt fixed are screwed.
- Perform maintenance work when the machine is stopped only.
- Make sure that the machine can not be started by unauthorized persons!

This label is located on the belt protection in on the right side of the machine direction of travel.

Description: Never open or remove safety devices with running motor.



4.0 FUNCTIONING

4.1 Processing task

The mobile shredding unit has been constructed and designed for the shredding and defibration of organic materials.

4.2 Construction (Illustration 4.1)

Illustration 4.1
EP 5500 Shark
Construction

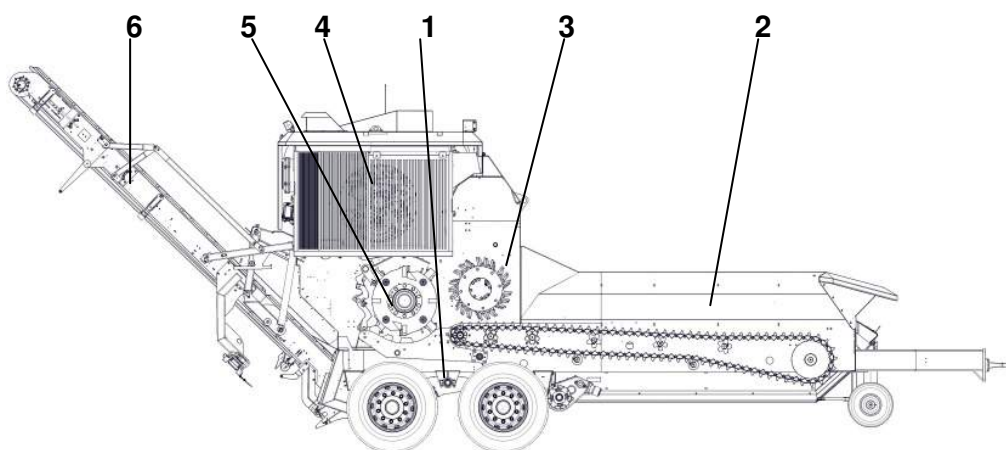

- | | |
|------------------------|----------------------------|
| 1. Track lying chassis | 2. Loading chute with feed |
| 3. Draw-in roller | 4. Motor |
| 5. Shredding unit | 6. Discharge conveyor |

4.3 Functional principle (Illustration 4.2)

Loading the machine

The material is fed to the rotor via heavy duty floor conveyor (endless floor). The take-in height of the aggressive draw-in roller of up to 520 mm assures that bulky materials can be shredded, too.

Material infeed

The hydraulic drive of the heavy duty floor conveyor (endless floor) as well as the draw-in roller is infinitely variable, thus assuring optimum adaptation to the material to be processed.

The material is rough-pressed by endless floor conveyor and draw-in roller and then fed to the rotor.

Shredding the material

From top to bottom turning rotor reduces the material and supplies it to the cutting up basket. With the different basket positions as well as the flap position over hydraulic cylinders, can be adjusted the desired cutting up degree.

Discharging the material

After the crushing unit shredded material is discharged with the discharge conveyor.

The discharge conveyor allows shake out compost windrow heaps of up to 3.5 m (4.5 m optional) height. Advantages lie in the work safety in the ejection area, in easily stratification of the shredded material and higher heaps.

*Illustration 4.2
EP 5500 Shark
Shredding unit
Functional principle
Rotor 48 flails*

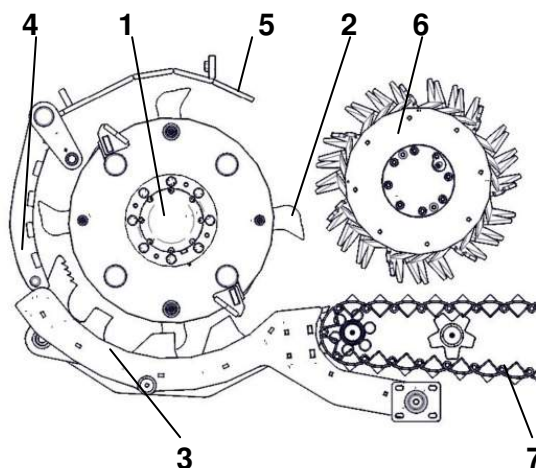

1. Rotor
2. Flail
3. Basket
4. Cutting up flap
5. Impact plate
6. Draw-in roller
7. Endless floor

*Shredding unit
Functional principle
Rotor 40 flails*

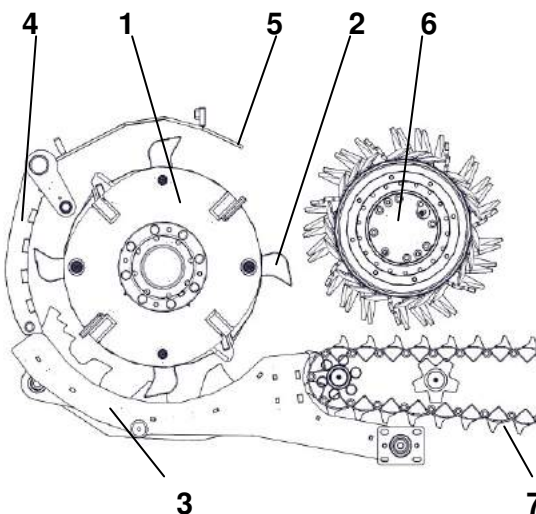

1. Rotor
2. Flail
3. Basket
4. Cutting up flap
5. Impact plate
6. Draw-in roller
7. Endless floor

*Shredding unit
Functional principle
Rotor 32 flails*

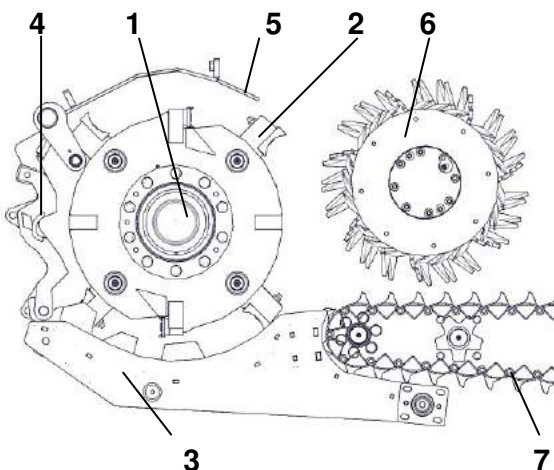

1. Rotor
2. Flail
3. Basket
4. Cutting up flap
5. Impact plate
6. Draw-in roller
7. Endless floor

Emergency off button on the control cabinet



Emergency off switch



Emergency off key on the control cabinet



Emergency off key on the radio remote control



4.4 Safety equipment

4.4.1 Emergency off button

Two stop buttons are mounted on the machine. If one of those, or the one on the control, will get pushed in, the engine will Stop immediately.

The activated stop button will stay engaged until it will get unlocked through a clockwise rotation under tension.

4.4.2 Motor Stop key

The key "Motor Stop" is in the control cabinet and on the radio remote control.

If this key is pressed, the engine will get switched off, hydraulic functions, the central lubrication and the fuel pump will get turned off. After undershoot of the revolution limit the coupling will get disengaged.

4.4.3. Main battery switch

Main battery switch



The battery main switch is located on the left side in the direction of travel of the machine beside the control cabinet. Only when the battery main switch in position is taken "OFF", the machine is switched off completely

4.4.4 Siren

Siren



On the machine, a siren is mounted.. The siren is located on the left side in the direction of travel of the machine next to the engine control box. The siren switches on, if a command from the control cabinet or remote control for functions is effected.



Siren is installed in the engine control bot



4.5 Safety equipment for maintenance and repair work

4.5.1 Motor hood securing



Motor hood securing

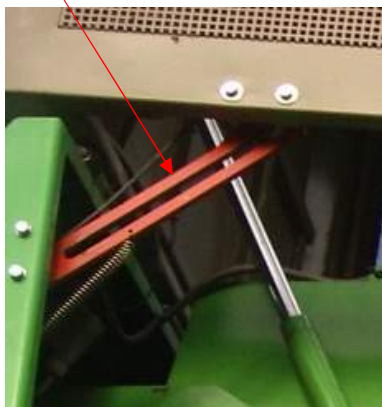

Bolt is engage



WARNING

Crushing hazard due to open and closed the hood!

Lowering the hood can result in serious injury to death.

Therefore hood is equipped with a hood securing.

For all maintenance and repair work the hood can be opened.

On opening the hood of the bolt must fully engage in the bore of the safety bar. In this case, the hood is completely opened and secured.

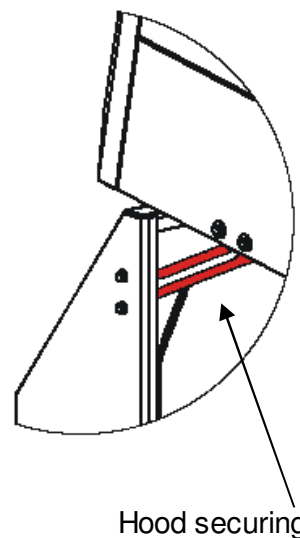
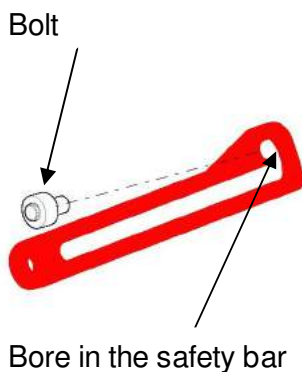

No person must be at and under the hood when it is lowered!

4.5.2 Coupling securing



WARNING

Crushing hazard by all maintenance and repair work!

The rotor is no longer balanced if the plug-in shaft is removed by pulling it out. The rotor will turn! For all maintenance and repair work without coupling securing the rotor could start to move and cause serious injury.

- Perform maintenance and repair work when the machine is stopped only.
- Before performing any maintenance or repairs the coupling cylinder must be secured with securing rod and bolts.

Coupling securing

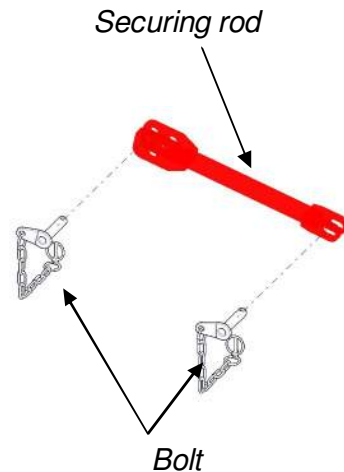
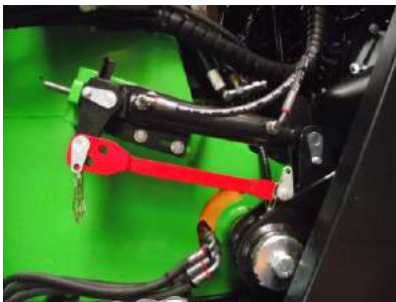

The hydraulic cylinder must be move in. A message "clutch disengaged" comes at the control cabinet.

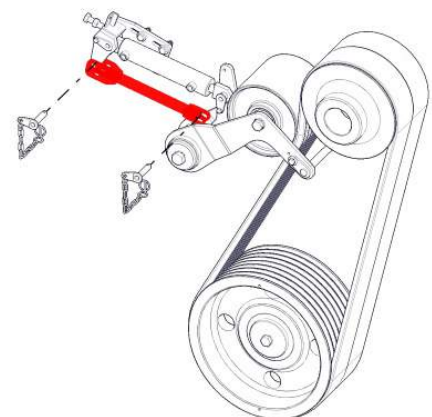

The securing rod must be attached at the hydraulic cylinder and fastened with bolts, so that the hydraulic cylinder does not extend.

4.5.3 Infeed roller securing

WARNING



Crushing hazard by all maintenance and repair work in draw-in area!

For all maintenance and repair work, the infeed roller must be moved hydraulically to top in order to achieve better the rotor or crushing basket

Infeed roller is down without Bolt

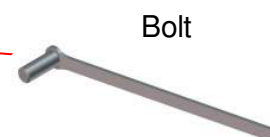

When the infeed roller is in motion, this can cause serious injury.

- The infeed roller must be staked out after moving up with the bolt.

Infeed roller is moved up and staked out with bolt

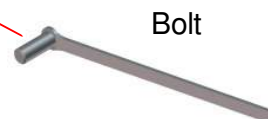

4.5.4 Discharge conveyor securing



DANGER

Danger of crushing in all maintenance and repair work!

There are a free space, danger zone D, between crushing unit and discharge conveyor at maintenance position. When the hydraulic cylinders come in motion, is occurred mortal danger to human life.

Not enter the danger zone D without cylinder lock! (Support rod (1) und bolts (2) both sides)

- Read and follow the description of security measures before you start maintenance and repair work. See Chapter 7, Point 7.7

Securing discharge conveyor cylinders maintenance position

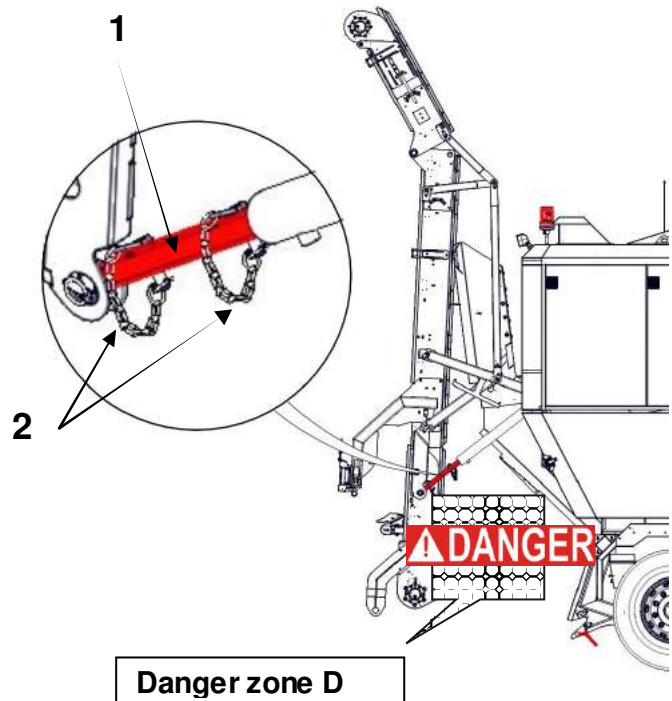

Bolts

- Insert the support rod on both sides over hydraulic cylinder;
- Put the safety bolts in each hole of the support rod.
- Secure the bolts with the lynch pin, the pins are on secure bolts.

5.0 W.TRONIC 2600 QUICK REFERENCE

5.1 OVERVIEW

Follow the machine manual, security advice and description of the service panels! By using the remote control consider the corresponding instruction manual!

Trough breakdown or fault of the control, the engine can run uncontrolled, through self-loosing switching on the drives and functions can cause danger.
While working at the machine please switch of the main battery switch.

Overview of the keys:

Function control:

Control box and remote control

Service control

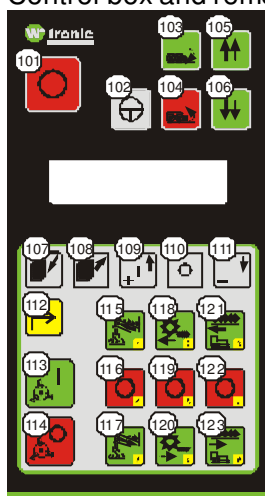

Version V1.0

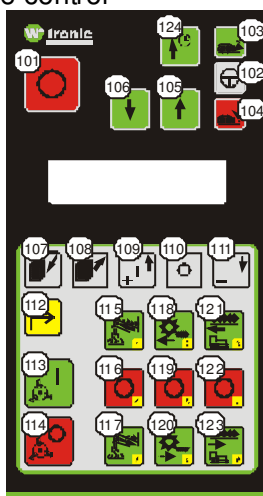

Version V1.1

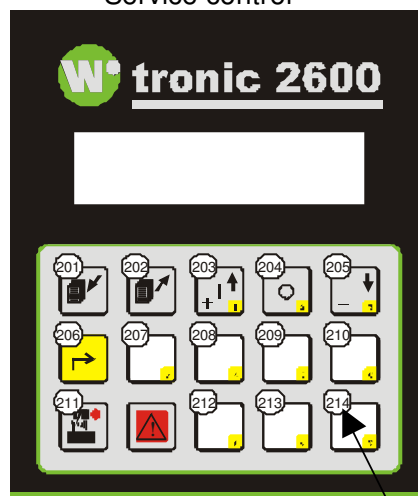

Version V1.0 und V1.1

Key number

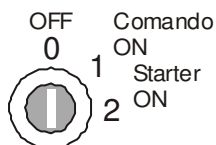

KEY SWITCH

Position 0: the unit is off.

Position 1: The whole unit will get connected „operable“.

Position 2. Operation of the engine starter while the position the same.

Switch on process:

1. Switch on key holder: Hold until message „W.tronic 2600 installation“.
2. Continuing turning the key holder for engine – START.
3. Pressing coupling with key T113, wait until the coupling is completely pressed in (manual watching).
4. Put engine with function „revolution“ to full throttle.
5. Switch on the functions: discharge conveyor forward, in feed roller backwards, endless floor forward.

PALM BUTTON

Several palm buttons are mounted on the machine. If one of those, or the one on the control, will get pushed in, the engine will Stop immediately. See you function: key “engine-stop”.

The operation of a button will get shown in the display!

The activated palm button will stay engaged until it will get unlocked through a clockwise rotation under tension.

EMERGENCY OFF

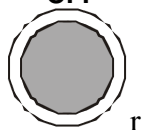

ATTENTION: The rotor of the machine is having a long flow!

5.2 OPERATION Functions – control at the control box / remote control unit

T 101



Engine-stop: The engine will get switched off, hydraulic functions, the central lubrication and the fuel pump will get turned off. After undershoot of the revolution limit the coupling will get disengaged.

Functions with continuous operation:

T 113



T 114



T113 = clutch engage / T114 = clutch disengage

T 115



T 116



T 117



T115 = conveyor forward / T116 = conveyor off / T117 = conveyor backward

T 118



T 119



T 120



T118 = in feed roller forward / T119 = in feed roller off / T120 = in feed roller backward

T 121



T 122



T 123



T121 = endless floor forward / T122 = endless floor off / T123 = endless floor backward

Functions with tip operation/ Transparency keyboard V1.0:

T 105



Drive forward: press key: machine drives forward until releasing the key.
press key 2 times: machine drives forward for 4 seconds.

T 106



Drive backward: press key: machine drives forward until releasing the key
Pressing the key, the machine automatically stops driving forward.

Functions with tip operation/ Transparency keyboard V1.1:

T 105



Drive forward: press key: machine drives forward until releasing the key.
press key 2 times: machine drives forward for 4 seconds.

T 106



Drive backward: : press key: machine drives forward until releasing the key.
Pressing the key, the machine automatically stops driving forward.

T 124



Drive forward time: press key: machine drives forward for 4 seconds.
If the machine drives and those Key is pressed, then stops the machine.

Functions with V1.0 und V1.1:

T 103



Engage the wheel drive: Press key until wheel drive is completely pressed on.
Disengage the wheel drive: First press the grey release key:
Display message: „Release for engaging wheel drive“
then press the key for disengaging the wheel drive within 3 seconds.

T 102



T 104



..

CAUTION: Secure the machine against accidental roll away!

5.3 Description of the W.tronic 2600 chain drive (with crawler only)

The chain control takes place via the 4 buttons T103, T104, T105 and T106 on the control cabinet or via the joystick and buttons T102, T103, T104 of the remote control unit.

The chain speed can be adjusted in steps via the function „Drive crawler“. The speed applies to the travel function via the buttons in the control cabinet and is the maximum speed at full joystick displacement.

Operation at the control box:

Film keyboard V1.0

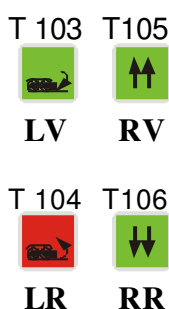

Film keyboard V1.1

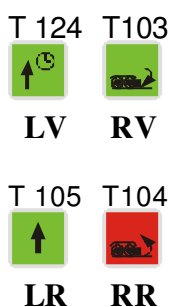

The assigned chain runs forwards or backwards as long as the respective button is pressed.
(It is possible after engine start of the machine only.)
drive forward → press buttons LV and RV simultaneously
drive backward → press buttons LV and RV simultaneously

Operation at the remote control unit:



Button T102 must be pressed for the release of the joystick. Then displace the joystick within 10 seconds to move with chain drive.

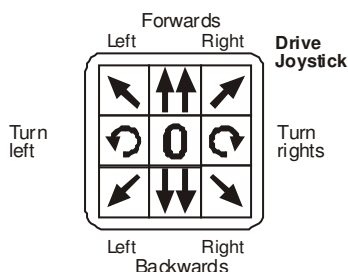

The machine drives in the direction in which the joystick is displaced. If the joystick is displaced horizontally, the machine turns on the spot. The chains run against each other.
The speed of the chains is influenced between low and full displacement.
The speed adjustment via buttons T201 and T202 in the option "Drive crawler" determines the maximum speed at full joystick displacement.

T 103 5 Sek. drive forward



T 104 2 Sek. drive forward



The machine can automatically move forward for approx. 2 sec or 5 sec. The automatic travel function can be cancelled by pressing the button again or by pressing another button.

Adjustment of the speed for the chains:

Scroll in the menu via buttons T 201 and T202 to the option „Drive crawler“:



Drive V crawler
20 %

Indicate the current speed for the crawler chains. The lowest speed is always set when the machine is switched on.

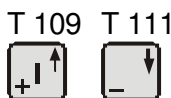

The speed can be changed via buttons T109 and T111.

5.4 Quick dial functions at the control box / remote control unit

T 107 T108



Scroll between the functions forward and backward.

Call directly with the quick dial keys the function:

T 112 T 115 bis T 123

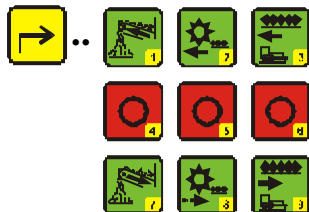



Press key T112 for release.

Display: „**Release for quick dial keys 1-9**“

Select within 3 seconds the requested function with the number key between 1 – 9 (Keys T115 until T123).

Functions, operable with the menu/quick dial keys:

Function:	Quick dial key	T 109 	T 110 	T 111 
Revolution	1	Full throttle		Idle speed
Infeed roller lift	2	lift	off	
Flap	3	rough	off	fine
Feed hopper	4	lift	off	lower
Hood	5	lift	off	lower
Support bar	6	lift	off	lower
Change revolution	7	high		low
Conveyor lift / lower	8	lift	off	lower
Clean rev. fan	9	start	stop	
Rake	-	lift	off	lower

5.5 OPERATION Service – control

After turning on the key switch the following „standard message“ is showing of after the initialisation:

Work hours	12h34
Service in:	88h

Shows the working hours: currently 12 hours and 34 minutes.
Shows that in 88 hours the next service becomes due.

After the start of the engine it changes to the following message “engine dates”:

n= 795 25°C 80%Tank
Load: 11% RB-v: 0%

Shows the revolution, the engine temperature and the tank capacity
Shows the load of the engine and the speed of the endless floor.

Other indication:

n-Rot. 500 25%Adbl
Nzkl: 90% Geg.s: 80%

Shows the revolution and the AdBlue tank capacity
Zeigt die Klappstellung von Nachzerkleinerung und Gegenschneide an.

T 206



With the key T206 you can switch between these indications.

Scroll between the notices „operating hours“ and „engine dates“.
As soon a menu got chosen, it can get appeal.

T 207



Press key T207: Retrace out of a menu, if the number keys are not active.
If the following message is in the display, the retrace occurs with the confirmation of the key T206

Confirm with Enter
Menu back →

T 201 T 202



Pressing the keys T201, T202 in the menu „standard message“, „engine dates“:
Skip into the menu options. With further key press of T201, T202 the next menu will get chosen. A menu will get selected with the enter key (T206).

Menu functions:

• Menu feed speed

6 Infeed roll a endless floor speed 100 ?

The variable 6 shows the nominal value for the control
regler of the endless floor speed and that for infeed roller.

With the key T206 the input for a new value gets activated. With the number keys from 0-9 (see below) a new value gets entered. This value must get confirmed with key T206. With the keys T201, T202 the entered value can get cancelled, if it did not get confirmed yet.

• Service menü

You can switch in the service menu between the submenus with the keys T201 and T202. The submenus get selected with the enter key (T206).

Submenus:

• Service/ maintenance

Confirm with Enter No maintenance →
--

With the T206 key menu is leaving without confirming the maintenance.

With the key T202 you have the choice if the maintenance should get confirmed:

Confirm with Enter Confirm maintenance →

The accomplished maintenance is getting confirmed with the key T206. The service hour meter get put to the value of variable 1 (service interval). With key T207, the menu will get left without confirming the maintenance

Maintenance - counter got reset

Message that service hour meter got reset. Continuing is with key T207.

• Central lubrication

V 36 grease system 0 88 off

By pressing the key T_AUF (T203) the cirde of the central lubrication will get started (grease time in variable 4). By pressing the key T_AB (T205) an already going cirde will get stopped. You can leave the menu by pressing the key T207.

• low RPM protection

Low RPM protection active With key O deaktiv.

The current state of the low RPM protection is shown. After the engine start the low RPM protection is active. With the key T_AUS (T204) the low RPM protection will become deactivated.

Low RPM prot. no aktiv With key I aktivie.

With key T_AUF (T203) the low RPM become activated.

• Failure memory

No.: 1 E: 509 Time: 1627:28:44

No.: 1 shows the already appeared failures
E: 509 shows the failure number (509 = Fuel tank empty).
1627:28:44 shows that the failure operated by working hour 1627, Min. 28 and 44 Sec.
With the keys T201 and T202 you can switch and check if more Failure numbers are existed.
With the key T207 you can leave the menu.

Engine: SPN - List

Error from 1 → SPN: 3277 FMI: 0

Indication from engine error number.
With the keys T201 und T202 you can switch and check if more error numbers are existed.
With the key T207 you can leave the menu.

• Menu backward

With the key T207 you can return to the previous menu.

• Menu variables

Eingabe der Code-Nummer 2384 zur Verstellung der Variablen

1 Service - Interv. →
400?

The variable 1 shows the hour quantity for the service interval. In the menu service/maintenance, after the confirmed maintenance, the services hour meter will get set to this value.

With the key T206, the input for a new value gets activated. With the number keys from 0 until 9 a new value will get put in. This has to get confirmed with key T206. With the keys T201, T202 the entered value can get cancelled, if fit did not get confirmed yet.

That's how the following values (1-13) can get adjusted.

List of variables see 6 User variable description.

• Line out

Line out test when the engine is OFF

With the keys T201 and T202 can change between the lines out.

With the keys T203, T204 and T205, the lines out are switched.

Rücksprung ins vorherige Menü mit der Taste T207.

• Line in

Anzeige der Eingangszustände.

Mit den Tasten T201 und T202 kann zwischen den Eingängen gewechselt werden

With the key T207 you can return to the previous menu.

• Menu backward

With the T207 key return to main menu.



Switching functions on or off, testing outputs or in the service menu central lubrication system.



Choice, if the handlings of the functions occur with the remote control unit or with the control box.

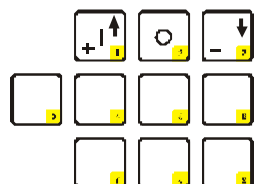

Number pad for input of new values, for examples variables values.

Key T203, T204, T205; T207, T208, T209, T210; T212, T213, T214



Warning signal at high temperature of the hydraulic oil, polluted hydraulic oil filter, hydraulic oil is missing, polluted engine air filter, engine cooling water is missing, engine temperature is to high, engine oil pressure to low, emergency stop is pressed, bypass at a hydraulic valve outputs.

5.6 User variables - Description

Stand: 02.04.2013

Default-variables from Software V 2.06.00 to V 2.24.000, Plate WB250 ST

User variables: Code 2384

Variable	Description	Unit	Default	Permissible values
1	Service-hour interval (Time in hours between maintenance, service)	1 hour	400	0 to max. 600
2	Reversible fan interval (Time between the reversible fan cleanings)	1 min	75	15 to 90
3	Grease system interval Time between lubrication cycles	1 min	30	30 to 480
4	Grease system: lubrication time ON Time for one lubrication cycle	1 min	4	1 to 16
5	Endless floor control: Index value for torque in %	1 %	80	10 to 100
6	Endless floor control: max. flow / max. speed. Adjustable from the operator.	1 mA	1600	0 to max. 2400"
7	Low RPM protection: start up RPM in case of high RPM	1 U/min	1700	0 to 2500
8	Low RPM protection: start up RPM in case of low RPM	1 U/min	1550	0 to 2500
9	Rev. time infeed roller	In 0,1 sec.	15	0 to 50
10	Rev. time endless floor	In 0,1 sec.	10	0 to 50
11	Options for languages		0	0 = german 1 = foreign language
12	Return time from menu	0,1 sec.	200	20 to 2000
13	Driving time for automatic-Forward-Driving of wheel drive	In 0,1 sec.	40	10 to 100
14-	Detail for display lighting 16 digit at the control box	1 min	180	1 to 180
15	Clock pulses for a lubrication cycle of the grease system unit	1 impulse	19	5 to 80
16-20	Not used			

Stand: 25.09.2013

Default-variables from Software V 3.12.000, Platine WB250 ST

User variables: Code 2384

Variable	Description	Unit	Default	Permissible values
1	Service-hour interval (Time in hours between maintenance, service)	1 hour	400	0 bis max. 600
2	Reversible fan interval (Time between the reversible fan cleanings)	1 min	75	15 bis 90
3	Grease system interval Time between lubrication cycles	1 min	30	30 bis 480
4	Grease system: lubrication time ON Time for one lubrication cycle	1 min	4	1 bis 16
5	Endless floor control: Index value for torque in %	1 %	80	10 bis 100
6	Infeed roller total speed influence the endless floor (RB)- and infeed roller speed (EZW)	1 %	1600	0 bis 100
7	Infeed roller speed (diagnosed with the variable 6 the EZW-speed)	1 %	100	0 bis 100
8	Endless floor speed (diagnosed with the variable 6 the RB-speed)	1 %	100	0 bis 100
9	Low RPM protection: start up RPM in case of high RPM	1 U/min	1700	0 bis 2500
10	Low RPM protection: start up RPM in case of low RPM	1 U/min	1550	0 bis 2500
11	Options for languages		0	0 = deutsch 1 = Fremdsprache
12	Driving time for automatic-Forward-Driving of wheel drive	ln 0,1 sec.	40	10 bis 100
13	Discharge conveyor safety mode: 0=no, 1=yes		0	0, 1
14-	ECO-Mode: Engine torque limit	ln %	20	1 bis 100
15	ECO-Mode: Time to shutdown to idle in case of shortfall of torque limit	1 sec.	30	10 bis 65535
16-20	No used			

5.7 Error number – description

Stand: 18.09.2013

from Software V3.12000, Plate WB250 ST V1.2

No.	Description of errors	Effect
501	EMERGENCY STOP activated	Engine is switched off, hydraulic-valve OFF
502	Relay Remote-Plate activated	Engine is switched off, hydraulic-valve OFF
503	hydraulic oil temperature too high	Engine is to idle speed, hydraulic-valve OFF
504	Hydraulic oil missing	Engine is switched off, hydraulic-valve OFF
505	Hydraulic filter dirty	Engine is to idle speed, hydraulic-valve OFF
506	Coolant missing	Engine is switched off, hydraulic-valve OFF
507	Air filter dirty	Engine is to idle speed, hydraulic-valve OFF
508	Alternator not charging	Error-display
509	Fuel tank empty	Error-display
510	Engine preheat on	Error-display
511	Oil pressure to low	Engine is switched off, hydraulic-valve OFF
512	Engine temperature hot with temp.> EE-Var.31 (95°)	Engine is to idle speed, hydraulic-valve OFF
513	Engine temperature overheated with temp.> EE-Var.30 (100°)	Engine is switched off, hydraulic-valve OFF
514	Error MAN-engine (control SPN-Number)	Saving of SPN -numbers in SPN -error memory
515	Error with initialization the plate via CAN-Bus	Error-display
516	Error Relay K1	Voltage U-Enterprise is missing, control of relay K1, LED relay K1
517	Error Relay K2	Voltage U-ON is missing, control of EMERGENCY STOP, relay K2, LED relay K2
518	Error Relay K3	Voltage U-ON is missing, control of EMERGENCY STOP, relay K3, LED relay K3
519	Error Relay remote plate	Voltage U-ON is missing, control of EMERGENCY STOP, control of connection plug X8 from plate WB 250 FUNK
520	Particle filter polluted	Engine is to idle speed, restart for error confirmation
521	Grease system empty	Error-display
522	Clutch disengaged because RPM under 500	Engine is to idle speed, clutch disengage
523	Adlue Tank empty	Error-display
524	Error CAN-Bus to FFR	Error-display, possibly no more connection to Engine-Can-Bus
--	Cutter bar disengaged	Turns off with function cutter bar the outputs, the engine returns to idle speed.
--	Conveyor standing	Conveyor is shortly backward for reversing time, then again forward
--	Conveyor safety	Conveyor lift/lower, respectively hood lift/lower does not work. Set bolt properly, respectively conveyor lift is possible.
601	Open Load of output No. electrically 1 (conveyor forward)	Error-display
602	Open Load of output No. electrically 2 (conveyor backward)	Error-display
...		
6xx	Open Load of output No. electrically XX	Error-display
701	Short circuit on output No. electrically 1 (conveyor forward)	Output No. 1 is switched off from output of plate WB 250 AM.
702	Short circuit on output No. electrically 2 (conveyor backward)	Output No. 2 is switched off from output of plate WB 250 AM.
...		
7xx	Short circuit on output No. electrically XX	Output No. xx is switched off from output of plate WB 250 AM.

Assignment of the "Output No. - Electrical 1" to outputs, for example, "conveyor forward" can be seen from the occupancy plans for the hydraulic motor terminal box, motor terminal box and plant terminal box.

5.8 Description of the radio remote control

The operation of the machine functions takes place as described in the instructions for the control cabinet „Operation of the Function Control Unit on the Control box / Radio Remote Control Unit“.

In addition, there is a service menu with the following functions:

Service menu:

T 112



The service menu is called up by pressing button T112 „ENTER“ several times:

- The capacity of the rechargeable battery is displayed as the first message:

Battery capacity	→
50 %	

Button T 112  is used for scrolling in menu.

Button T 110  is used to return from service menu. There is no return via menu option choose language.

- Indication the battery voltage, the current consumption and temperature

U = 6,95 V	→
I = 0.115A T = 31°C	

Button T 112 is used to continue in the menu.
Button T 110 is used to return from the menu

- Indication of charge voltage (permitted charge voltage: DC voltage: 12 to 24 VDC)

Charge voltage	→
U = 12,40 V	

Button T 112 is used to continue in the menu.
Button T 110 is used to return from the menu

- Language selection

Select language	→
Selection: 0	

Button T 112 is used to continue in the menu.
With the T 109 key (Choice 1) and T 110 (Choice 0), can change between the text issue in German (Choice 0) and the text issue in the choose language (Choice 1).

- Switch the radio remote control to standby mode.

Standby	→
Yes <1> No <0>	

Button T 112 is used to continue in the menu.
Button T 109 is used to switch the radio remote control to standby mode. When the charge function is active, a return to standby mode is not possible.
Button T 110 is used to return from the menu.

- Search and change the radio channel.

Search channel →
Yes <1> No <0>

Mit Taste T 112 weiter im Menü.
Mit Taste T 109 wird das Menü für
Funkkanal suchen aufgerufen.
Button T 110 is used to return from the menu.

Search the radio channel. As the first entry the code number 2384:

Entry code number

Using the numerical buttons T 115 to T 123
and T 110 for „0“
Entry of the code number 2384.
After entry, confirm with T 112.

The current radio channel is searched for

Please wait . . .
Searching radio
channel 3

Wait until the search has finished.

- a) The correct channel has been found: Channel 5 is active

Radio channel 5
active !

Confirm radio channel with T 112
Return via T 110.

Next the channel of the radio module in the control cabinet can be changed.

External channel
5 ?

Using T 112, select menu for
numerical entry.
Entry of the new channel number - see
entry of variables.
Permitted values are 1 to 10 for channel
entry.
Return via T 110 without change.

The channel of the radio module in the remote control unit is changed here.

Internal channel
5 ?

Using T 112, select menu for
numerical entry.
Entry of the new channel number - see
entry of variables.
Permitted values are 1 to 10 for channel
entry.
Return via T 110 without change.

- b) No channel of the remote station has been identified.

No channel found!

On with T 112 or T 110

Skip these messages via T 112 or T 110:

External channel
65534 ?

Internal channel
5 ?

- Adjusting the variables of the radio remote control unit

Menu variables →
Yes <1> No <0>

Button T 112 is used to continue in the menu.
Button T 109 is used to call up the menu for setting the variables.
Button T 110 is used to return from the menu.

First enter the code number 2384:

Enter the code number

Button T 108 is used to return from the menu.
Using the numerical buttons T 115 to T 123 and 110 for „0“
Entry of the code number 2384.
After entry, confirm with T 112.

Setting variables menu:

Variable : 50 →
5 ?

The number of the variable is displayed in the first row.
The value of the variable is displayed in the second row.

Button T 112 is used to activate the entry for a new value. A new value is entered using the numerical buttons from 0 to 9. This value must be confirmed via button T 112.

The entered value can be deleted via buttons T 107 and T 108, if it has not yet been confirmed.

The following variables are adjustable. Code number 2384

Variable	Description	Unit	Default	Perm. Werte
50	Time joystick release	1 second	5	1 to 50
51	Time for display illumination ON after pressing button	1 second	120	1 to 30000
52	Shut-off time if button no longer pressed	1 minute	5	1 to 500
53	Display illumination 0 = Illumination via timer (var. 51) 1 = Illumination always ON 2 = Illumination always OFF		0	0, 1, 2

- Return from the service menu.

Menu back →
Yes <0>

Button T 112 is used to continue in the menu.
Button T 110 is used to return from the menu.

5.9 Description of the W-tronic 2600 reversible ventilator

Method of functioning

The control automatically reverses the direction of rotation of the cooling ventilators for a short time to clean the ventilation grilles.

The blades of the ventilator are adjusted to do so. Prior to this, the entire in feed is stopped and the motor speed is reduced to 1500 rpm. After the 14 second cleaning period, the ventilator is turned back again, the motor speed increases again and the in feed is restarted automatically.

This operation is always carried out when activated by the interval control (every 75 minutes), when cleaning is triggered manually by the operator (see Implement cleaning process immediately) or if the coolant temperature has reached the limit of 95 °C

Caution:

The independent delayed activation of the ventilator drives may cause danger!

The drives may unintentionally start up due to a fault or malfunction of the control unit!

→ When intervening with the machine, switch the main battery switch to "0".

→ The battery must be disconnected for revision and repair work.

Observe the motor temperature:

The cooling of the main motor is interrupted during the cleaning process!

Adjustment of the cleaning interval:

In the **menu Variables**, the reversible ventilator interval can be adjusted within a range of 15 min to 90 min via variable 2.

Implement cleaning process immediately:

A single cleaning process can be carried out immediately via the function **WL cleaning**.

V	WL cleaning
0	Start with '+'

Function test via menu outputs:

Function number 34: Reversible fan off Oil cooler elektr. and Reversible fan compr. off

V	34	Revers. fan	Reversible fan forwards	Oil cooler elektr. on. (not for hydr. oil cooler)
0	86	off	Reversible fan backwards	Reversible fan -compressor on.

Function number 27:(is active for hydraulic cooler only)

V	27	Revers. fan	Reversible fan forwards	Oil cooler hydraulic forwards on
0	20	off	Reversible fan backwards	Oil cooler hydraulic reverse on

5.10 Description of central lubrication

Method of functioning

The W.tronic 2600 switches an output using High-Side-PROFET to control the central lubrication. The output can be switched manually via the service menu. If the motor is running, control is cyclical with a set time interval. The cycle time of a lubrication process can either be set directly in a time setting or checked by means of clocked pulse monitoring.

Setting the variables:

Access the menu for variable settings in the service menu

- Enter code number 2384, confirm with T206.
- It is possible to set the following values:

Variable	Description	Unit	Default	Perm. value
3	Central lubrication Interval Time between 2 lubrication cycles	1 minute	30	30 bis 480
4	Central lubrication time, Time for 1 lubrication cycle	1 minute	4	1 bis 16
15 or 25	Clock pulses for a lubrication cycle	1 Impuls	19	5 bis 80

• Switching the central lubrication on/off manually

The central lubrication unit can be switched on/off manually in the service menu:

V 36	Central lubric.
0 88	off

The T AUF (T203) button is used to start a cycle of the central lubrication (lubrication time in Variable 4).

The T AUF (T204) button is used to stop a cycle that is already running.

The T207 button is used to exit the menu.

• Description of automatic control of the central lubrication:

a) Lubrication time via time control

Once the motor has started, the interval counter will be set to the time set in Variable 3.

Once the interval time has elapsed, the central lubrication is started. The output is on for the duration of the lubrication time (set via Variable 4). The interval time is also reset.

b) Lubrication time via clocked pulse control

Once the motor has started, the interval counter will be set to the set time.

Once the interval time has elapsed, the central lubrication is started.

The output for the central lubrication unit will remain active as long as the set clocked pulse number has been achieved. The interval counter is reset.

c) Error message “Central lubrication empty”

E	Central lubric.
521	empty

This error message will come if pulses can no longer be counted by the central lubrication unit. After confirming with the T 112 button on the wireless remote control or on the control cabinet, the control can be operated normally again.

Check the following if this error occurs:

- Is the supply tank for the central lubrication empty?
- Switch on central lubrication manually. Check the LED for central lubrication – output (VD61 on the left next to relay K7); check the LED for central lubrication – pulses (VD2 on the lower left in the control cabinet) with approx. 13 seconds clock cycle flashing. If the LED VD2 for “Central lubrication ON” is constantly ON or OFF, then there is an error in the pulse detection or the supply tank is empty.

5.11 Description calibration FLAP / RAKE: (optional sensors for FLAP / RAKE is required)

Method of functioning when flap and rake with sensor for flap position



The flap position of shredding flap and rake will issue on the right 20-digit display.

For this purpose press the key T 206  up to following indication:

n-Rot. 500 25%Adbl Flap: 90% Rake: 80%	Indicates the rotor speed and the AdBlue Fuel tank capacity Indicates the flap position of shredding flap and position of rake
---	---

Calibration of the flaps for FLAP/RAKE:

1. Operate the flap for shredding on the left display (see Chapter 4):
Adjust the flap to the setting that should correspond to 0% flap position.
Also bring the flap for the rake in position for 0% flap position.

2. Select the menu service on the right display using the key T201  and T 202 .

Confirm with enter
Service menu →

Confirm with key T 206 .

Select the menu calibration in the menu service:

Confirm with enter
Calibration →

Confirm with key T 206 .

Select in menu calibration the choice "1st value is closed":

Confirm with enter
1st value is closed →

Confirm with key T 206 .

The sensor values for flap 0% and rake 0% were saved now.

Press the key T 207  so often, until the main indicating appears again.

3. Operate the flap for shredding on the left display (see Chapter 4):
Adjust the flap to the setting that should correspond to 100% flap position.
Also bring the flap for the rake in position for 100% flap position.

4. Select the menu service on the right display using the key  und T 202 .

Confirm with enter
Service menu →

Confirm with key T 206 .

Select the menu calibration in the menu service:

Confirm with enter
Calibration →

Confirm with key T 206 .

Select in menu calibration the choice "1st value is open":

Confirm with enter
2d value open →

Confirm with key T 206 .

The sensor values for flap 100% and rake 100% were saved now.

Press the key  so often, until the main indicating appears again.

5.12 Description LEDs of Plate WB 250 ST V1.2

LED-Nr.	Input- Nr.	Description
VD1	X1.3-6	Input
VD2	X6.10	Input clock pulses central lubrication
VD3	X1.10	Input motor - coolant
VD4	X1.9	Input preheat
VD5	X1.8	Input alternator D+
VD6	X1.7	Input soot particle filter
VD7	X2.10	Input cutter bar 1 pressed on
VD8	X2.9	Input wheel drive on
VD9	X2.8	Input floor overloaded
VD10	X2.7	Input conveyor overloaded
VD11	X2.6	Input conveyor standing
VD12	X2.5	Input in feed roller overloaded
VD13	X2.4	Input hydraulic oil filter
VD14	X2.3	Input hydraulic oil level
VD15	X2.2	Input hydraulic temperature to high
VD16	X2.1	Input motor – air filter
VD17	X5.10	Input IN – 27 free
VD18	X5.9	Input engine torque
VD19	X5.8	Input EDC – flashing code
VD20	X5.7	Input conveyor safety - 5
VD21	X5.6	Input conveyor safety - 4
VD22	X5.5	Input conveyor safety - 3
VD23	X5.4	Input diesel tank empty
VD24	X5.3	Input conveyor safety - 2
VD25	X5.2	Input conveyor safety - 1
VD26	X5.1	Input cutter bar 1 disengage
VD39	Conductive strip connection on plate	Input key - starter
VD40	Conductive strip connection on plate	Input emergency - STOP
VD41	Conductive strip connection on plate	Input relay plate radio
VD47	Conductive strip connection on plate	Monitoring U-ON of K3
VD48	Conductive strip connection on plate	Monitoring U- Enterprise of K1
VD49	Conductive strip connection on plate	Monitoring U-ON of K2
VD58	X13.5	Endless floor forward
VD59	X13.6	Endless floor backward
VD60	X13.7	Engine starter OIN
VD61	X14.1	Central lubrication ON
VD62	X14.5	Clutch engage
VD63	X14.6	Clutch disengage

5.13 Automatic start / stop function

Keys for automatic start / stop:

T 113



T 114



T113 = AUTOMATIC start

T114 = AUTOMATIC stop

Automatic start sequence:

One after another, during the automatic start process, the clutch is engaged, the discharge conveyor is turned on, the motor is run at full throttle and the in feed roller and endless floor are switched on.

1. Turn ignition key on machine.
2. Start motor with ignition key on the machine.
3. Press "AUTOMATIC start" button:
 - The clutch is engaged (only possible in the idle speed range).
 - There is a wait until the rotor is running.
 - Detection via sensor input coupling rotor impulses or sensor black/white
 - The discharge conveyor is turned on after approx. 10 seconds.
 - After approx. 5 seconds, the motor is run at full throttle.
 - After approx. 3 seconds, the in feed roller is switched on.
 - After approx. 2 seconds, the endless floor is switched on.

Automatic stop sequence:

4. Press "AUTOMATIC stop" button:
 - Endless floor and in feed roller stop and briefly move backwards.
 - The motor changes to idle speed after approx. 10 seconds
 - The discharge conveyor is stopped after approx. 10 seconds.
 5. Press "AUTOMATIC stop" button again:
 - The clutch is disengaged.
 6. The motor can now be switched off with the "Motor stop" button.
 7. Switch off ignition.
- The automatic start process can be interrupted by pressing the "AUTOMATIC stop" button. In the same way, an automatic stop can interrupted by pressing the "AUTOMATIC start" button and an automatic start process is continued.
 - It is also possible to carry out the "Engage clutch", "Disengage clutch" functions separately using the menu (in the idle speed range).

5.14 Fuel pump function

Input fuel tank empty is active:

- After 10 seconds, the fuel pump is switched off.
- After 30 seconds, the error message "E509 fuel tank empty" is displayed and is saved in the error memory.

Input fuel tank empty is active:

- After 5 seconds, the fuel pump is switched on again, if this was previously turned off.

W.tronic 2600 Assignment Terminals motor hydraulic system

Stand 18.09.2013

	Abbrev.	Line out	Function No. for output configurations	Supply over	LED-Nr. of WB250 ST	Output No. electrically for output configuration.	Plug allocation on plate:
Pin	Engine terminal box vein allocation Harting plug in the switchgear cabinet (32pol)						
1	_+24V	U-control					ST-X1.1
2	GND	for U-control					ST-X1.2
3	Input	Soot parti de filter (+24V-active)			VD6		ST-X1.7
4	Input	Battery no charge D+			VD5		ST-X1.8
5	Input	Announcement pre-heat			VD4		ST-X1.9
6	KWN	Input Engine coolant missing			VD3		ST-X1.10
7	LF	Input Engine air filter dirty			VD16		ST-X2.1
8	ZS	Input Grease system Impulse			VD2		AMP7-X4.8
9	NZ	Input Flap-IN 0-10V					AMP7-X4.7
10	GS	Input Rake-IN 0-10V					AMP7-X4.8
11	RK	Input Rotor-dutch Impulse					AMP7-X4.3
12	Input	Input Rotor Impulse					AMP7-X4.5
13							
14							
15	GND						ST-X8.4
16	Input	Input IN25 +24V-active (EDC-flash code					ST-X5.8
17							
18	LB	Lamplighting	24	U-ON		31	AM4-X1.10
19	HUPE	HORN	23	U-ON		32	AM4-X1.11
20	K-OKE	Reversible fan backwards, compressor	34	U-ON		87	ST-X13.1
21	K-KO, OV	Reversible fan forwards, Oil cooler elektic.	34	U-ON		86	ST-X13.2
22	Mot-Stop	Engine-STOP	31	U-ON		80	ST-X13.3
23	K-AN	Engine starter	32	U-Em-Stop		90	ST-X13.7
24	K-EDC	Relay EDC ON	35	U-Em-Stop		81	ST-X13.8
25							
26							
27							
28							
29	_+24V	Supply voltage 2 veins (27,28)					ST-X15.1-X15.2
30	_+24V	Supply voltage 2 veins (29,30)					ST-X15.3-X15.4
31	GND	Supply voltage 2 veins (31,32)					ST-X15.5-X15.6
32	GND	Supply voltage 2 veins (33, gnge)					ST-X15.7-X15.8
The wiring of the CAN bus is made by separate 2 pole cable:							
	CAN-Bus	Engine-CAN-H					ST-X8.1
	Engine	Engine -CAN-L					ST-X8.2



Operation Manual

EP 5500 Shark

	Abbrev.	Line out	Function No. for output configurations	Supply over	LED-Nr. of WB250 ST electrically for output	Plug allocation on plate:	
Pin Hydraulic terminal box vein allocation Harting plug 1 (40pol) W. tronic2600							
1	KE	Clutch engage	1	U- Enterprise		91 ST-X14.5	
2	KA	Clutch disengage	1	U- Enterprise		92 ST-X14.6	
3	RV	Endless floor forward (prop) (with AMP7)	2	U-ON		96 AMP7-X1.2	
4	GND	Endless floor forward (GND) (with AMP7)				AMP7-X1.3	
5	RR	Endless floor backward (with AMP7)	2	U-ON		89 AMP7-X1.4	
3	RV	Endless floor forward (prop) (without AMP7)		U-ON		96 ST-X13.4	
4	GND	Endless floor forward (GND) (without AMP7)				ST-X13.5	
	RR	Endless floor backward (without AMP7)		U-ON		89 ST-X13.6	
6	BV	Conveyor forward	3	U-ON		1 AM1-X1.2	
7	BR	(Conveyor backward)	3	U-ON		2 AM1-X1.3	
8	BH	Conveyor lift	4	U-ON		3 AM1-X1.4	
9	BS	Conveyor drop	4	U-ON		4 AM1-X1.5	
10	NF	Flap fine	5	U-ON		5 AM1-X1.8	
11	NG	Flap rough	5	U-ON		6 AM1-X1.9	
12	FH	Feed hoper lift	15	U-ON		7 AM1-X1.10	
13	FS	Feed hoper drop	15	U-ON		8 AM1-X1.11	
14	FV	LKV	Drive forward, Crawler: chain left forward	7	-	U-ON	9 AM2-X1.2
15	FR	LKR	Drive backward Crawler: chain left back	7	-	U-ON	11 AM2-X1.4
16	FE	RKV	Wheel drive engage Crawler: chain right forward	6	-	U-ON	13 AM2-X1.8
17	FA	RKR	Wheel drive disengage Crawler: chain right back	6	-	U-ON	15 AM2-X1.10
18	SFH	GND	Support bar lift Crawler: GND L KV	11	-	U-ON	10 AM2-X1.3
19	SFS	GND	Supp. bar drop Crawler: GND LKR	11	-	U-ON	12 AM2-X1.5
20	BLH	GND	Sidewall left lift, Crawler: GND RKV	18	-	U-ON	14 AM2-X1.9
21	BLS	GND	Sidewall left drop Crawler: GND RKR	18	-	U-ON	16 AM-2X.11
22	EV	In feed roll forward (with AMP7)	8	U-ON		17 AM3-X1.2	
23	ER	In feed roll backward (with AMP7)	8	U-ON		18 AM3-X1.3	
22	EV	In feed roll forward (without AMP7)	8	U-ON		17 AM3-X1.2	
23	ER	In feed roll backward (without AMP7)	8	U-ON		18 AM3-X1.3	
24	EH	In feed roll lift	9	U-ON		19 AM3-X1.4	
25	ÖKV	Hydraulic-oil cooler forward	27	U-ON		20 AM3-X1.5	
26	ÖKR	Hydraulic-oil cooler backward	27	U-ON		21 AM3-X1.8	
27	HH	Hood lift	12	U-ON		22 AM3-X1.9	
28	HS	Hood drop	12	U-ON		23 AM3-X1.10	
29	HV/DU	Hydraulic circulation, pressure-free circulation	17	U-ON		25 AM4-X1.2	
30	MH	Cutter bar / rake lift	13	U-ON		26 AM4-X1.3	
31	MSI	Cutter bar / rake drop	13	U-ON		27 AM4-X1.4	
32	RBL	Crawler brake off	22	U-ON		28 AM4-X1.5	
33	U	Pressure switch cutting bar disengage (210bar)			VD26	ST-X5.1	
34	M	Pressure switch cutting bar 1 / rake on (165bar)			VD7	ST-X2.10	
35	E	Pressure switch in feed roll back (180bar)			VD12	ST-X2.5	
36	S	Pressure switch conveyor standing (180bar)			VD11	ST-X2.6	
37	B	Pressure switch conveyor overloaded (165bar)			VD10	ST-X2.7	
38	R	Pressure switch endless floor backward (170bar)			VD9	ST-X2.8	
39	S	Pressure switch wheel drive on			VD8	ST-X2.9	
40		GND, Masse (Vein 40 u. gnge)				ST-X14.9-X14.10	
	with AMP7:	Cabinet design from V3.00.000 (Var. 50=0 und 1)					
	without AM P7:	Cabinet design to V2.24.00 (Var. 50=2)					
		With crawler-type vehicle enterprise instead of output module AM2 a proportional module AMP is used					
		Stand there are not the functions with crawler-type vehicle and the function side wall left would					
		have on another output module to be put, if the function is needed.					

	Abbrev.	Line out	Function No. for output configurations	Supply over	LED-Nr. of WB250 ST	Output No. electrically for output configuration	Plug allocation on plate:
Pin	Hydraulic terminal box vein allocation Harting plug 1 (32pol) W.tronic2600						
1	BRH	Sidewall right lift	19	U-ON		33	AM5-X1.2
2	BRS	Sidewall right lift drop	19	U-ON		34	AM5-X1.3
3	LBV	Special function 2 / Left cross conveyor forward	20	U-ON		35	AM5-X1.4
4	LBR	Special function 2 / Left cross conveyor backward	20	U-ON		36	AM5-X1.5
5	SI	Hydraulic wrench / Shaker screen on	14	U-ON		37	AM5-X1.8
6	RBV	GS Safety / Right cross conveyor forward	21	U-ON		38	AM5-X1.9
7	RBR	GS Safety / Right cross conveyor backward	21	U-ON		39	AM5-X1.10
8	Exit	FREE for valve output		U-ON		40	AM5-X1.11
9	Exit	FREE for valve output		U-ON		41	AM6-X1.5
10	Exit	FREE for valve output		U-ON		42	AM6-X1.3
11	Exit	FREE for valve output		U-ON		43	AM6-X1.4
12	Exit	FREE for valve output		U-ON		44	AM6-X1.5
13	Exit	FREE for valve output		U-ON		45	AM6-X1.8
14	Exit	FREE for valve output		U-ON		46	AM6-X1.9
15	Exit	FREE for valve output		U-ON		47	AM6-X1.10
16	Exit	FREE for valve output		U-ON		48	AM6-X1.11
17	Exit	FREE for valve output		U-ON			
18	Exit	FREE for valve output		U-ON			
19	Exit	FREE for valve output		U-ON			
20	Exit	FREE for valve output		U-ON			
21	Exit	FREE for valve output		U-ON			
22	Exit	FREE for valve output		U-ON			
23	Exit	FREE for valve output		U-ON			
24	Exit	FREE for valve output		U-ON			
25	Input	Proximity switch 1 conveyor safety			VD25		ST-X5.2
26	Input	Proximity switch 2 conveyor safety			VD24		ST-X5.3
27	Input	Proximity switch 3 conveyor safety			VD22		ST-X5.5
28	Input	Proximity switch 4 conveyor safety			VD21		ST-X5.6
29	Input	Proximity switch 5 conveyor safety			VD20		ST-X5.7
30	Input	Pressure switch -FREE-IN26-24V-active			VD18		ST-X5.9
31	Input	Pressure switch -FREE-IN27 GND-active			VD17		ST-X5.10
32		GND, Masse (Vein 32 u. 33gnge)					ST-X13.9-X13.10
						Plate:	
						ST= Control plate	
						AM=Output module	

	Abbrev.	Line out	Function No. for output configurations	Supply over	LED-Nr. of WB250 ST	Output No. electrically for output configuration	Plug allocation on plate:	
Pin	Plant terminal box vein allocation Harting plug in the switchgear cabinet (16pol)							
1	K-SCH	Grease system	36	U- Enterprise		88	ST-X14.1	
2	GND	Grease system	36				ST-X14.2	
3	K-KP	Fuel pump, WB250 ST Relay K7	33	U- Enterprise		82	ST-X14.3	
4	GND	Fuel pump	33				ST-X14.4	
5	HT	Input Hydraulic temperature to high			VD15		ST-X2.2	
6	HN	Input Hydraulic oil level to low			VD14		ST-X2.3	
7	HF	Input Hydraulic oil filter dirty			VD13		ST-X2.4	
8	DL	Input Diesel tank empty			VD23		ST-X5.4	
9	DF	Input Diesel tank level					ST-X6.1	
10	GND	Input Diesel tank level					ST-X6.2	
11	IN	Emergency-Stop					Emerg.-Stop cabinet	
12	OUT	Emergency-Stop					Radio- Emerg.-Stop ST-X10.3 IN2- Emerg.-Stop	
13	Exit	Warning lamp on	16	U-ON		24	AM3-X1.11	
14		GND					ST-X10.10	
15		GND, Masse					ST-X14.7	
16		GND, Masse					ST-X14.8	
		Fuel pump is switched off by EMERGENCY STOP for safety						

Control cabinet W.tronic 2600:

Stand: 02.04.2013

Plug arrangement Plate WB 250 ST from V1.2

Plug arrangement output modules AM1 to AM8: Plate WB 250 AM from V1.0

Alternative output modules prop. AMP2 and AMP7: Plate WB 250 AMP from V1.2

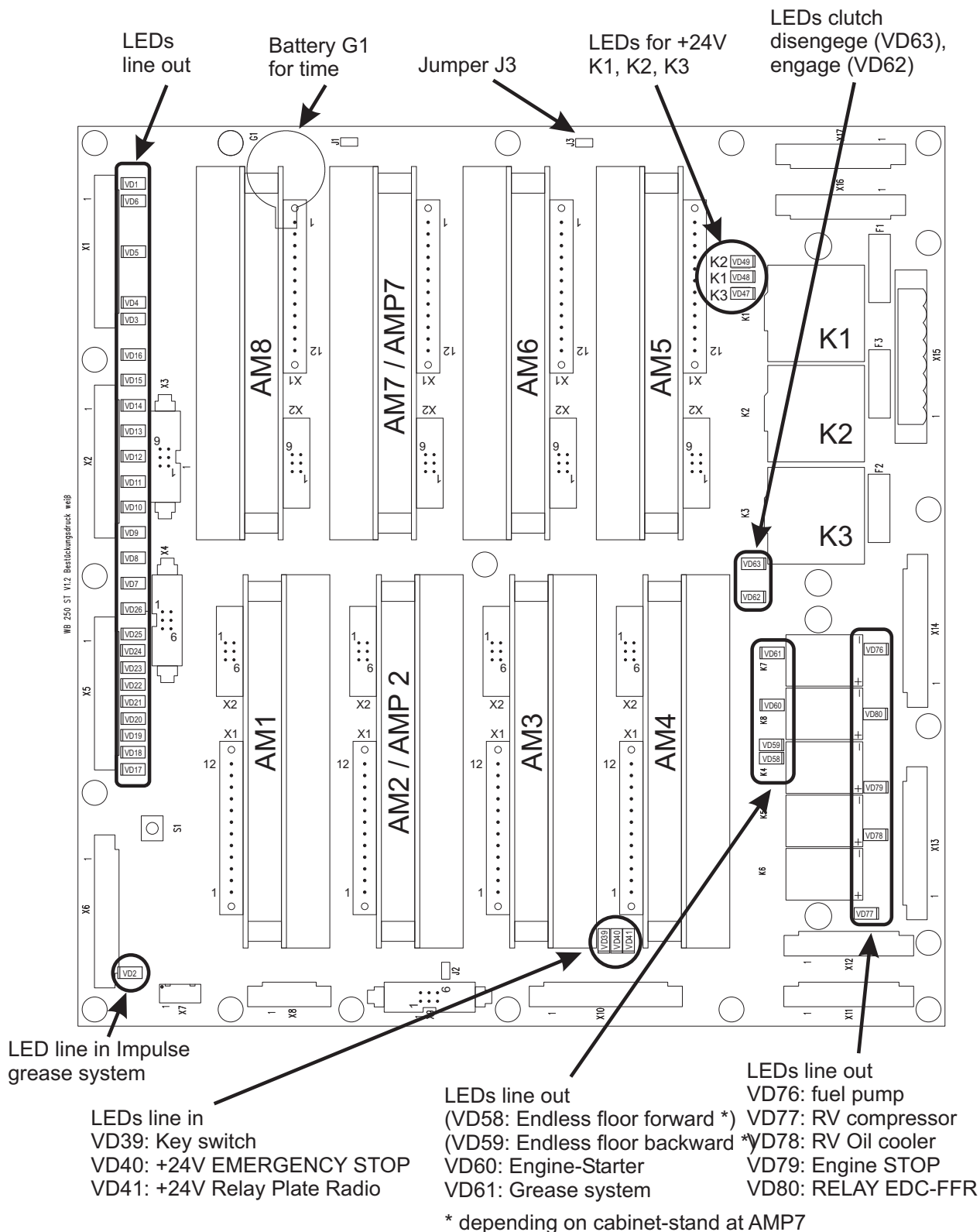

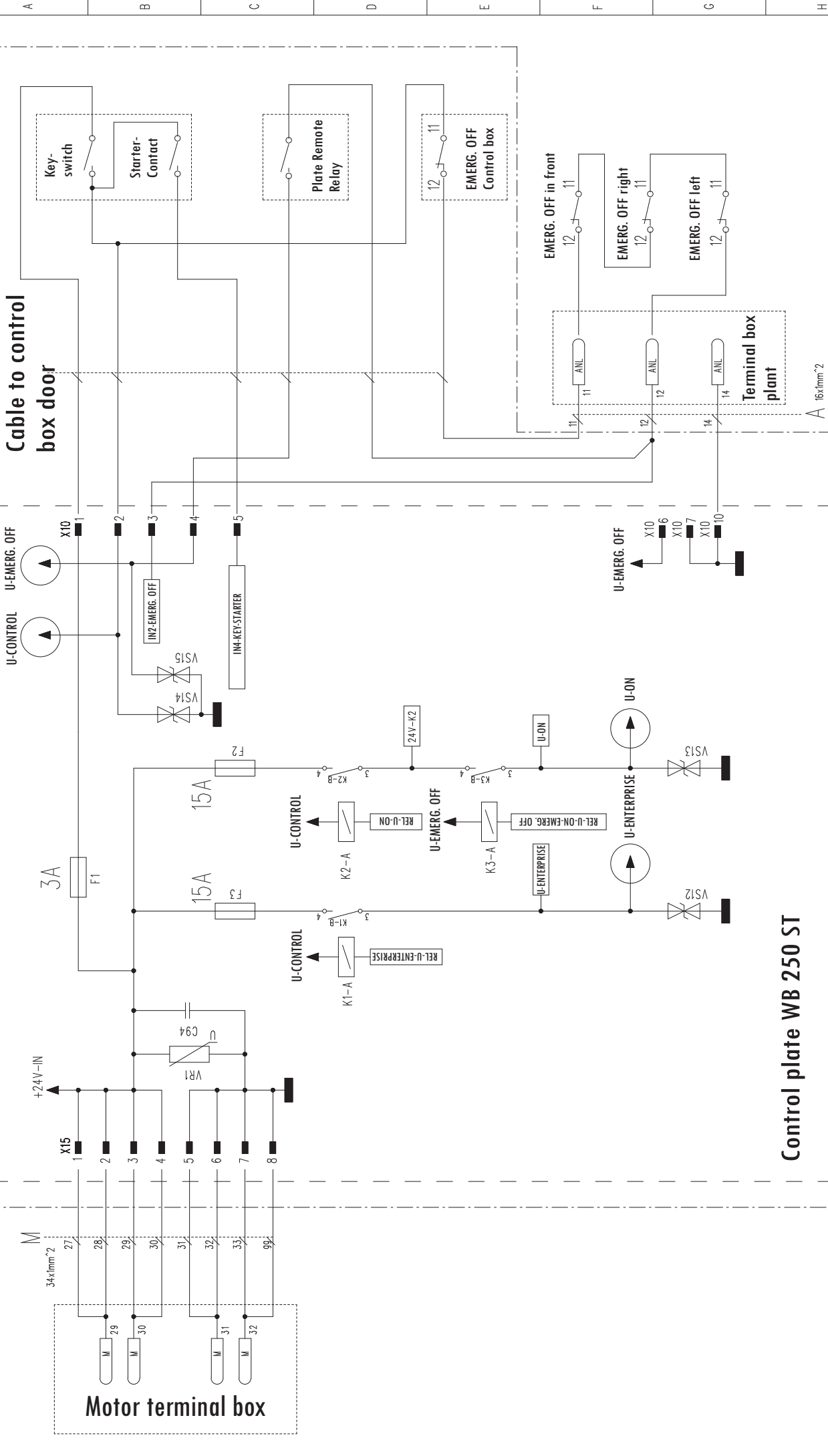

W.tronic 2600 V1.0
Schaltplan MZA Steuerung

Ariachne-CAD	Datum	Name
Bearbeitet	08.12.05	Endres L.

Blatt-Nr. 1
Blattzahl 13

Projekt: Willibald W.tronic 2600
Pfad/Dateiname: J:\W.tronic 2600\Ariachne Schaltplan\W.tronic_2600_V18.sch

Name	Datum	Zustand	Änderung
Endres	06.12.07	V.1.1	V.1.2
Endres	29.07.08	V.1.2	V.1.3
Endres	26.11.09	V.1.3	V.1.4
L.Enr.	19.05.11	V.1.4	V.1.5
L.Enr.	02.04.13	V.1.5	V.1.6
L.Enr.	18.09.13	V.1.6	V.1.7
L.Enr.	05.12.14	V.1.7	V.1.8

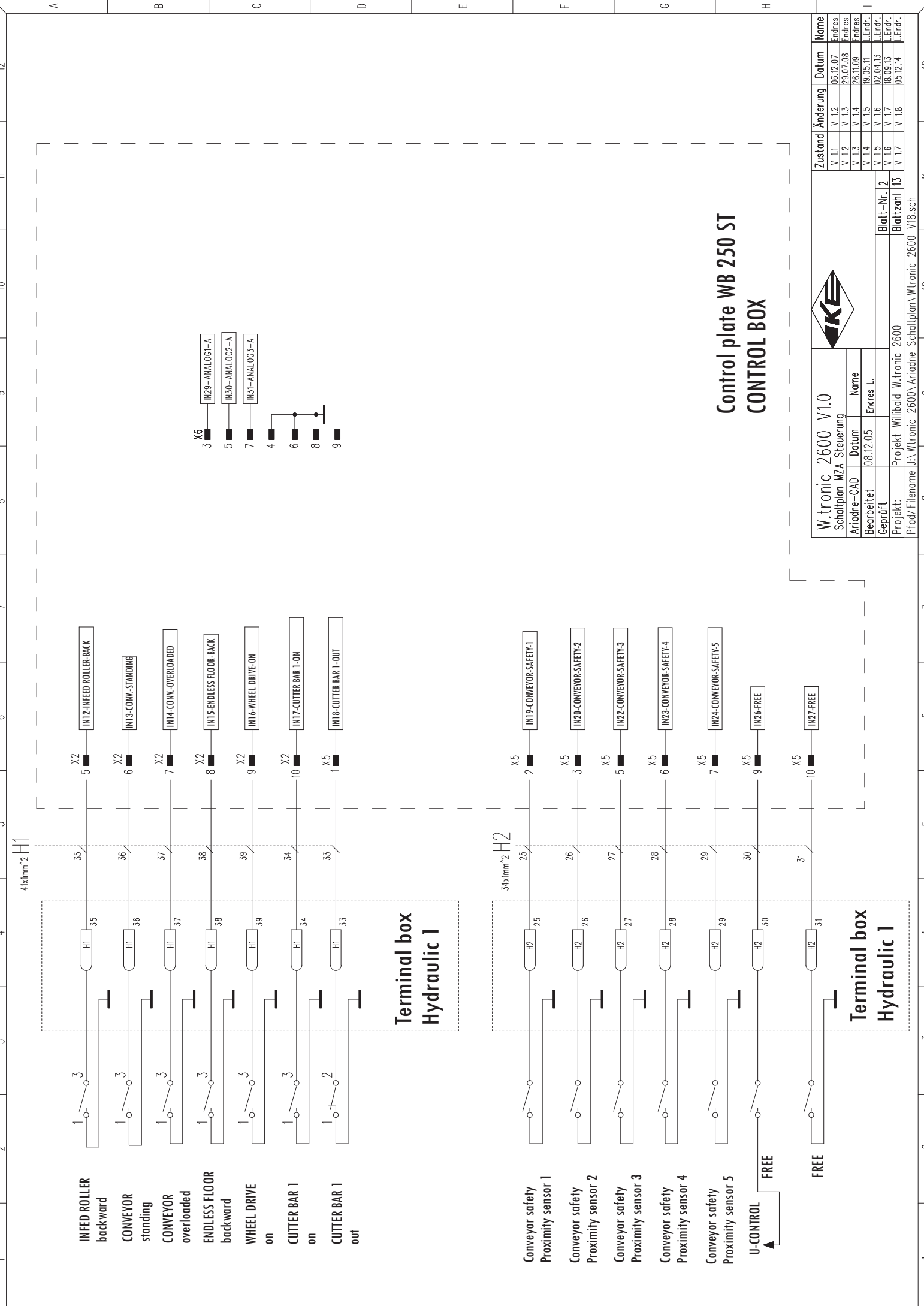

Control plate WB 250 ST CONTROL BOX



W.tronic 2600 V1.0		Schaltplan MZA Steuerung	
Ariadne-CAD	Datum	Name	
Bearbeitet	08.12.05	Endres L.	
Geprüft:	Projekt: Willibald W.tronic 2600	Blatt-Nr. 2	
Proj./Filename: J:\Wtronic 2600\Ariadne Schaltplan\Wtronic 2600 V18.sch		Blattzahl 13	

Zustand	Änderung	Datum	Name
V 1.1	V 1.2	06.12.07	Endres
V 1.2	V 1.3	29.07.08	Endres
V 1.3	V 1.4	26.11.09	Endres
V 1.4	V 1.5	19.05.11	L.Endr.
V 1.5	V 1.6	02.04.13	L.Endr.
V 1.6	V 1.7	18.09.13	L.Endr.
V 1.7	V 1.8	05.12.14	L.Endr.

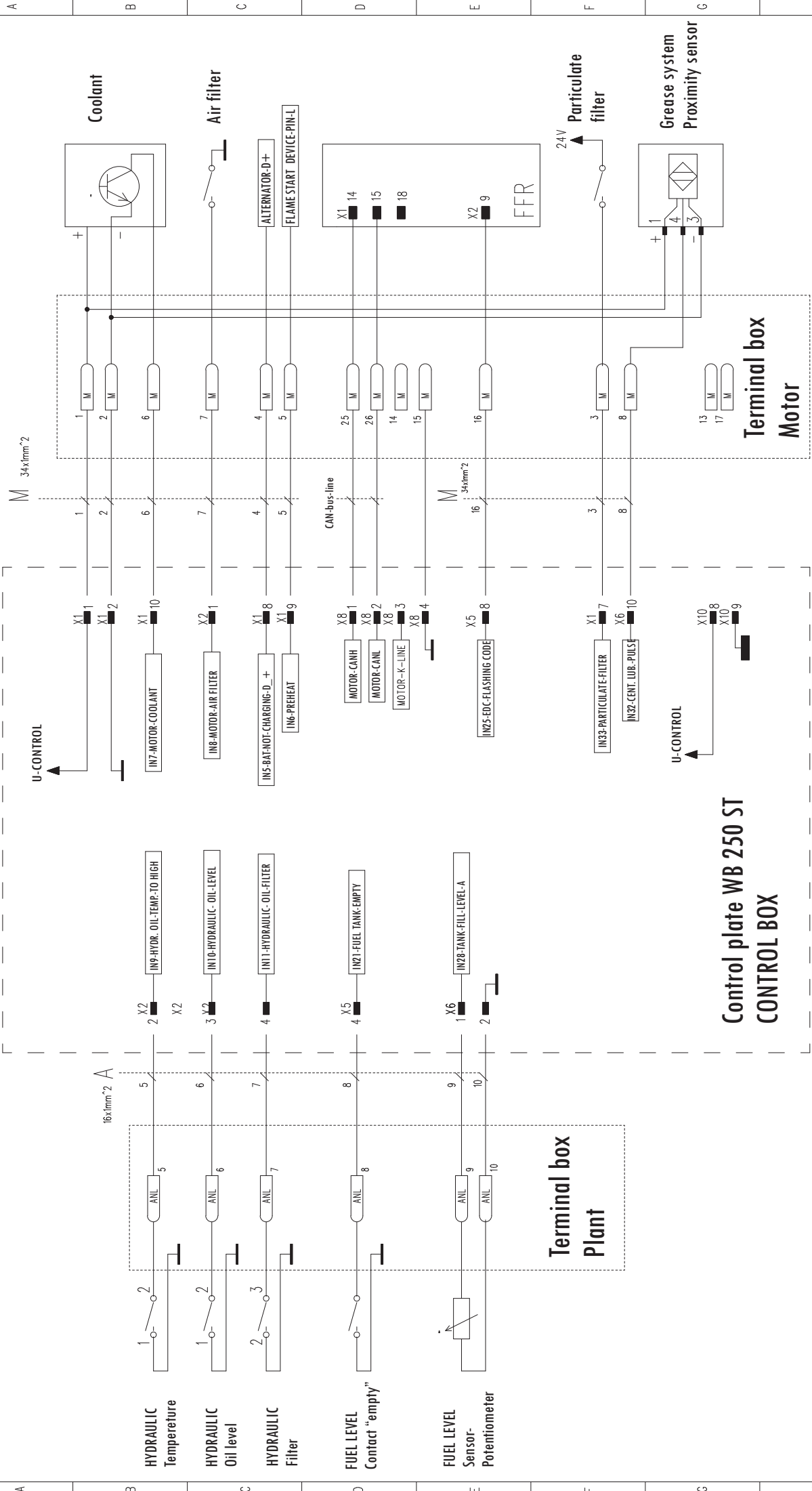

**Control plate WB 250 ST
CONTROL BOX**



W.tronic 2600 V1.0
Schaltplan MZA Steuerung

Ariachne-CAD	Datum	Name
Bearbeitet	08.12.05	Endres L.
Geprüft:	Projekt: Willibald W.tronic 2600	
Projad./Filename: J:\Wtronic 2600\Ariachne_Schaltplan\Wtronic_2600_V18.sch		

Zustand	Änderung	Datum	Name
V 1.1	V 1.2	06.12.07	Endres
V 1.2	V 1.3	29.07.08	Endres
V 1.3	V 1.4	26.11.09	Endres
V 1.4	V 1.5	19.05.11	Endres
V 1.5	V 1.6	02.04.13	Endres
V 1.6	V 1.7	18.09.13	Endres
V 1.7	V 1.8	05.12.14	Endres

Blatt-Nr. 3
Blattzahl 13

Control plate WB 250 ST

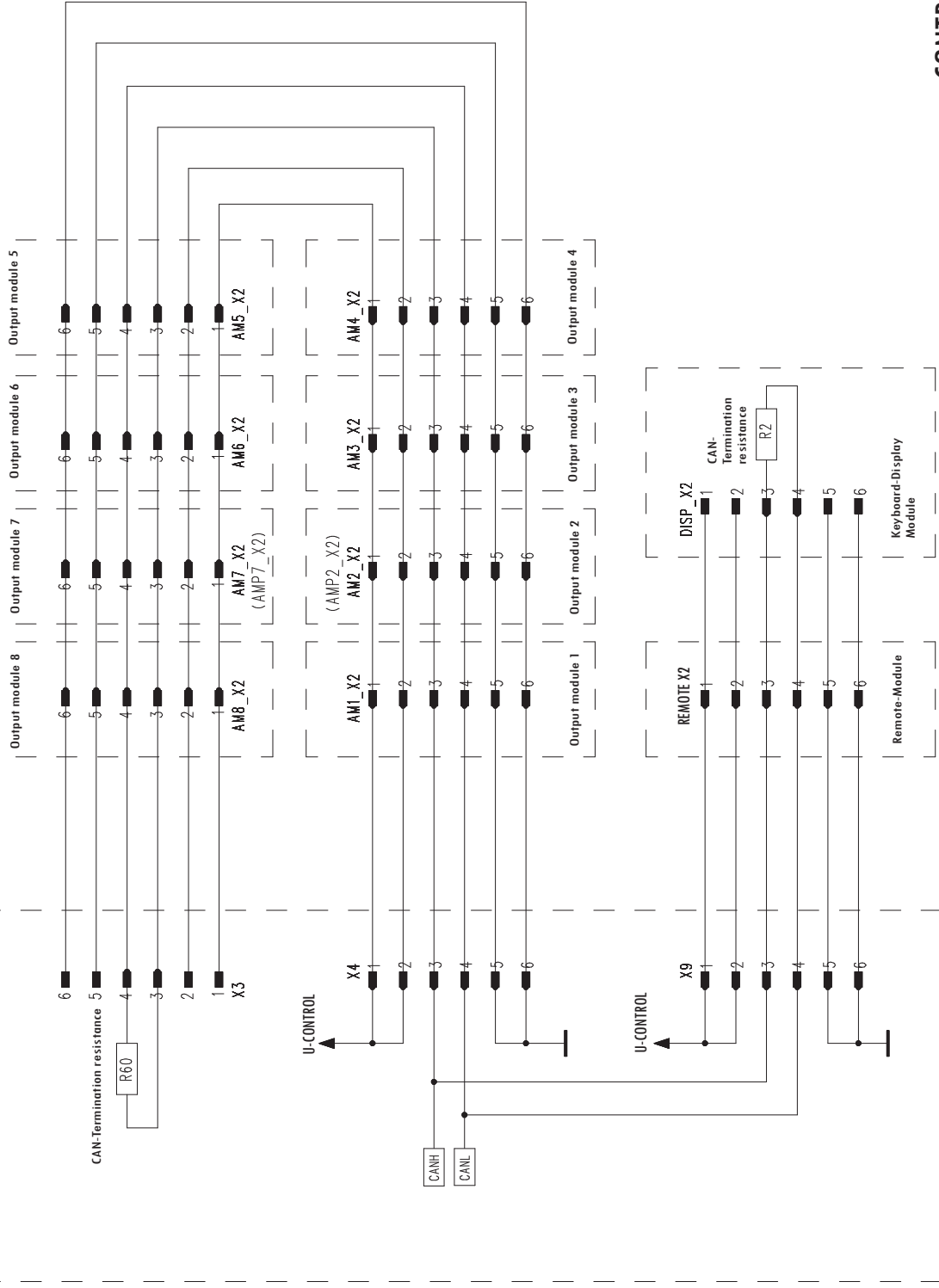

CONTROL BOX



W. tronic 2600 V1.0	
Schaltplan MZA Steuerung	
Ariadne-CAD	Datum
Bearbeitet	Endres I.
Geprüft:	Projekt: Willibald W. tronic 2600
Pfad/Dateiname: J:\W. tronic 2600\Ariadne Schaltplan\W. tronic 2600 V18.sch	

Name	Datum	Zustand	Änderung
Endres	06.12.07	V.1.1	V.1.2
Endres	29.07.08	V.1.2	V.1.3
Endres	26.11.09	V.1.3	V.1.4
L. Endr.	19.05.11	V.1.4	V.1.5
L. Endr.	02.04.13	V.1.5	V.1.6
L. Endr.	18.09.13	V.1.6	V.1.7
L. Endr.	05.12.14	V.1.7	V.1.8

Blatt-Nr. 4
Blattzahl 13

Control plate WB 250 ST CONTROL BOX

For Var. 50 = 2 (Control box version VZ.24.000
OTHERWISE AMP7-Module, sheet 13)

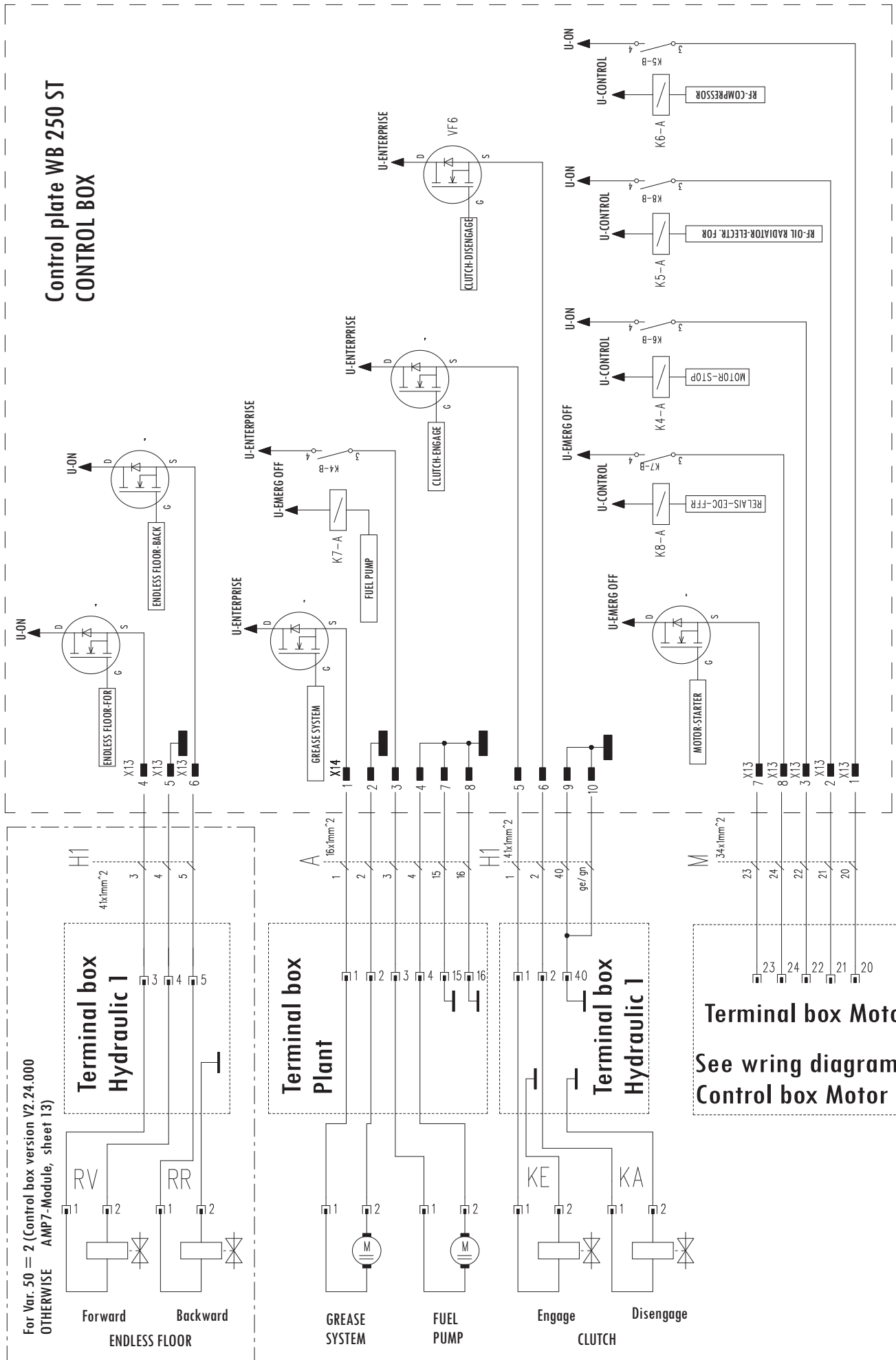

W. tronic 2600 V1.0	
Schaltplan MZA Steuerung	
Ariachne-CAD	Name
Bearbeitet 08.12.05	Endres L.
Geprüft:	Projekt: Willibald W. tronic 2600
	Prüf-/Dateiname: J:\W. tronic 2600\Ariachne Schaltplan\W. tronic 2600 V18.sch

Zustand	Änderung	Datum	Name
V. 1.1	V. 1.2	06.12.07	Endres
V. 1.2	V. 1.3	29.07.08	Endres
V. 1.3	V. 1.4	26.11.09	Endres
V. 1.4	V. 1.5	19.05.11	L. Endr.
V. 1.5	V. 1.6	02.04.13	L. Endr.
V. 1.6	V. 1.7	18.09.13	L. Endr.
V. 1.7	V. 1.8	05.12.14	L. Endr.

Blatt-Nr. 15
Blattzahl 13

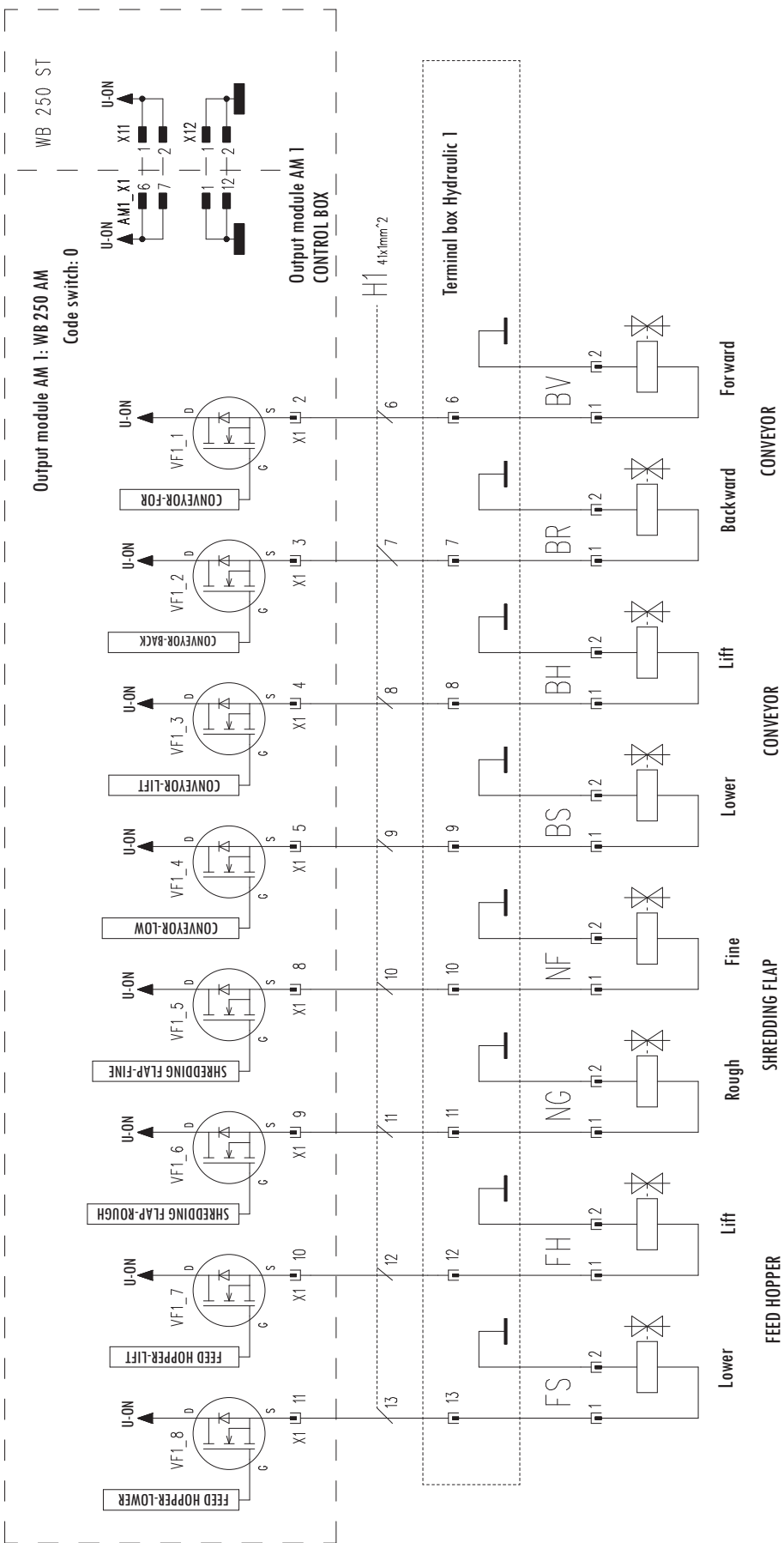

W. tronic 2600 V1.0
Schaltplan MZA Steuerung

Ariachne-CAD	Datum	Name
Bearbeitet	08.12.05	Endres L.
Geprüft:	Projekt: Willibald W. tronic 2600	
Pfad/Dateiname: J:\W. tronic 2600\Ariachne_Schaltplan\W. tronic_2600_V18.sch		

Zustand	Änderung	Datum	Name
V 1.1	V 1.2	06.12.07	Endres
V 1.2	V 1.3	29.07.08	Endres
V 1.3	V 1.4	26.11.09	Endres
V 1.4	V 1.5	19.05.11	L. Endr.
V 1.5	V 1.6	02.04.13	L. Endr.
V 1.6	V 1.7	18.09.13	L. Endr.
V 1.7	V 1.8	05.12.14	L. Endr.

Blatt-Nr. 16
Blattzahl 13

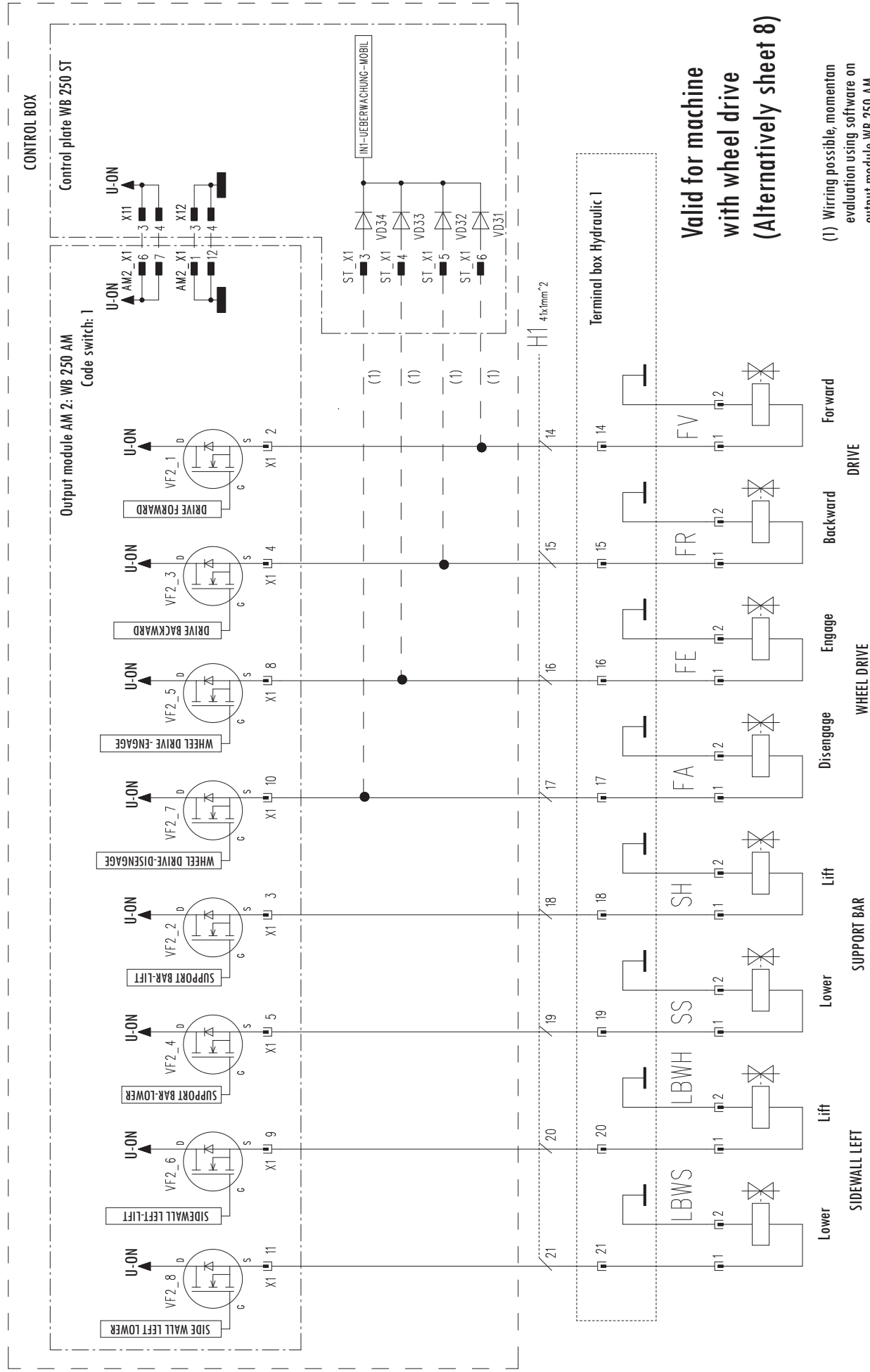

**Valid for machine
with wheel drive
(Alternatively sheet 8)**

(1) Wiring possible, momentan
evaluation using software on
output module WB 250 AM



W.tronic 2600 V1.0	
Schaltplan MZA Steuerung	
Ariadne-CAD	Datum
Bearbeitet	08.12.05
Geprüft:	Endres L.
Projekt:	Projekt: Willibald W.tronic 2600
Projad./Filename:	J:\Wtronic 2600\Ariadne_Schaltplan\Wtronic 2600 V18.sch

Zustand	Änderung	Datum	Name
V 1.1	V 1.2	06.12.07	Endres
V 1.2	V 1.3	29.07.08	Endres
V 1.3	V 1.4	26.11.09	Endres
V 1.4	V 1.5	19.05.11	L. Endr.
V 1.5	V 1.6	02.04.13	L. Endr.
V 1.6	V 1.7	18.09.13	L. Endr.
V 1.7	V 1.8	05.12.14	L. Endr.

Blatt-Nr.:	7
Blattzahl:	13

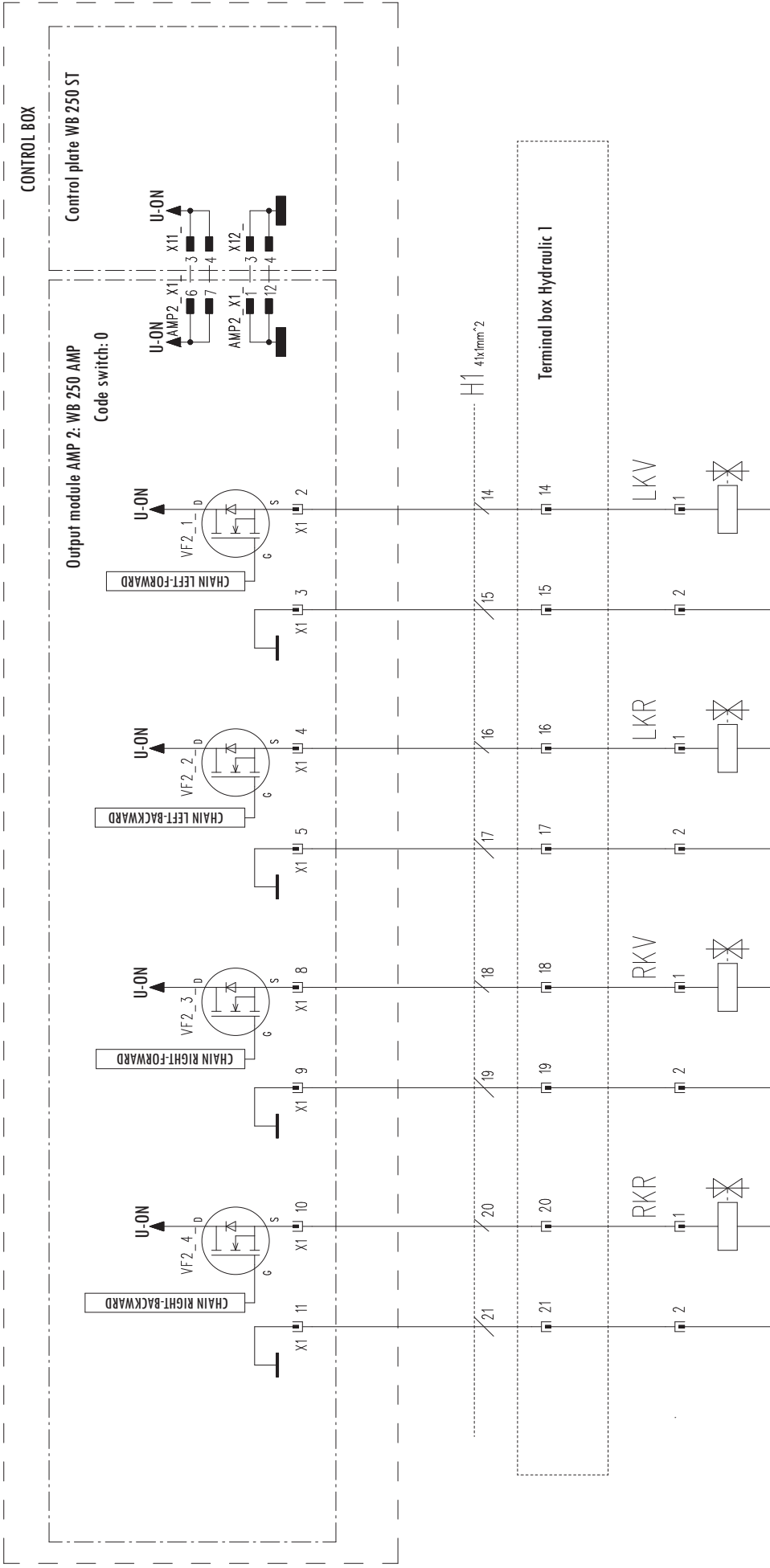

**Valid for machine
with wheel drive
(Alternatively sheet 7)**



W. tronic 2600 V1.0
Schaltplan MZA Steuerung

Ariachne-CAD	Datum	Name
Bearbeitet	08.12.05	Endres L.
Geprüft:	Projekt: Willibald W. tronic 2600	
Pfad/FileName: J:\W. tronic 2600\Ariachne Schaltplan\W. tronic 2600 V18.sch		

Zustand	Änderung	Datum	Name
V 1.1	V 1.2	06.12.07	Endres
V 1.2	V 1.3	29.07.08	Endres
V 1.3	V 1.4	26.11.09	Endres
V 1.4	V 1.5	19.05.11	L. Endr.
V 1.5	V 1.6	02.04.13	L. Endr.
V 1.6	V 1.7	18.09.13	L. Endr.
V 1.7	V 1.8	05.12.14	L. Endr.

Blatt-Nr. 18
Blattzahl 13

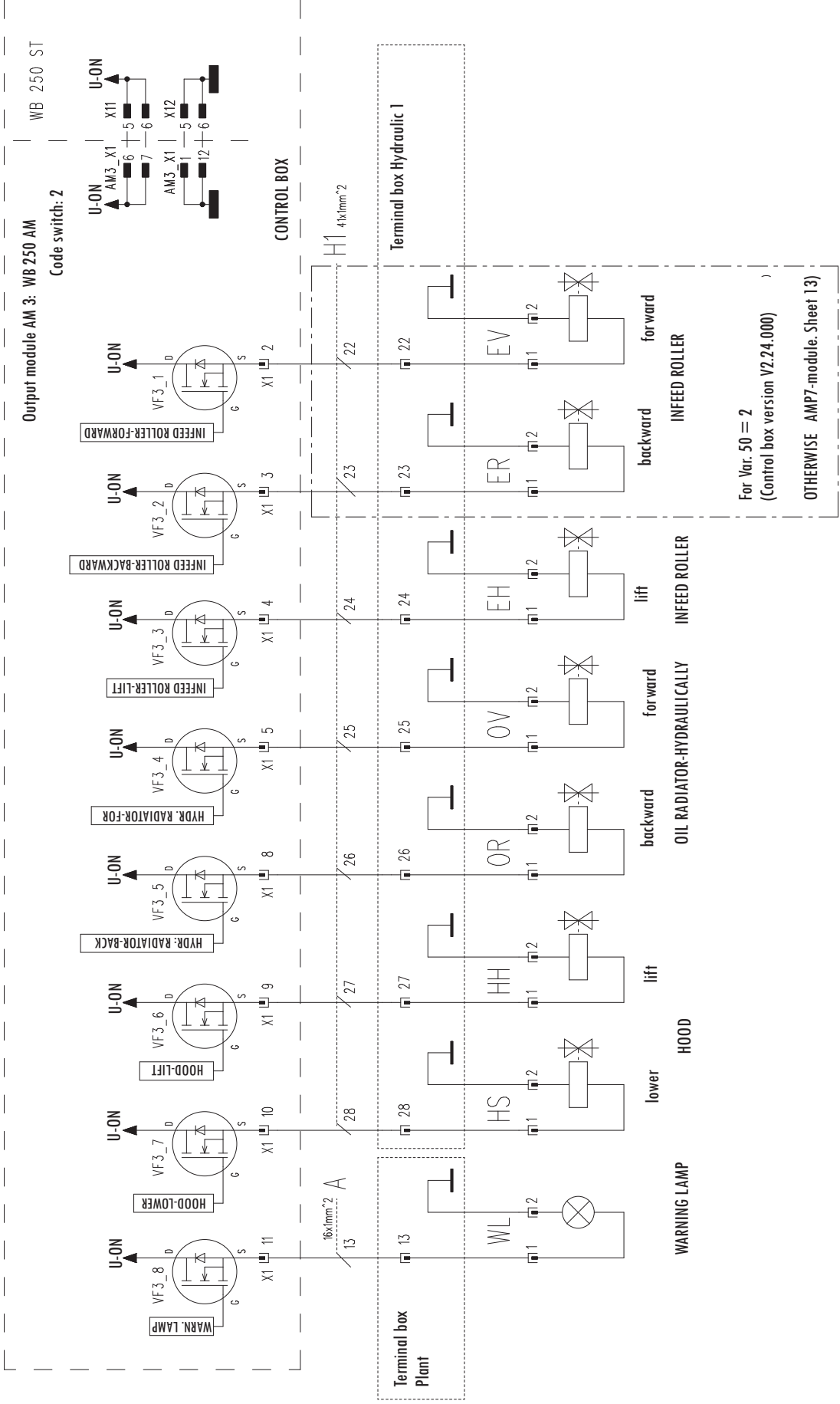

W. tronic 2600 V1.0
Schaltplan MZA Steuerung

Ariadne-CAD	Datum	Name
Bearbeitet	08.12.05	Endres L.
Geprüft:	Projekt: Willibald W. tronic 2600	

Zustand	Änderung	Datum	Name
V 1.1	V 1.2	06.12.07	Endres
V 1.2	V 1.3	29.07.08	Endres
V 1.3	V 1.4	26.11.09	Endres
V 1.4	V 1.5	19.05.11	L. Endr.
V 1.5	V 1.6	02.04.13	L. Endr.
V 1.6	V 1.7	18.09.13	L. Endr.
V 1.7	V 1.8	05.12.14	L. Endr.

Blatt-Nr. 9
Blattzahl 13

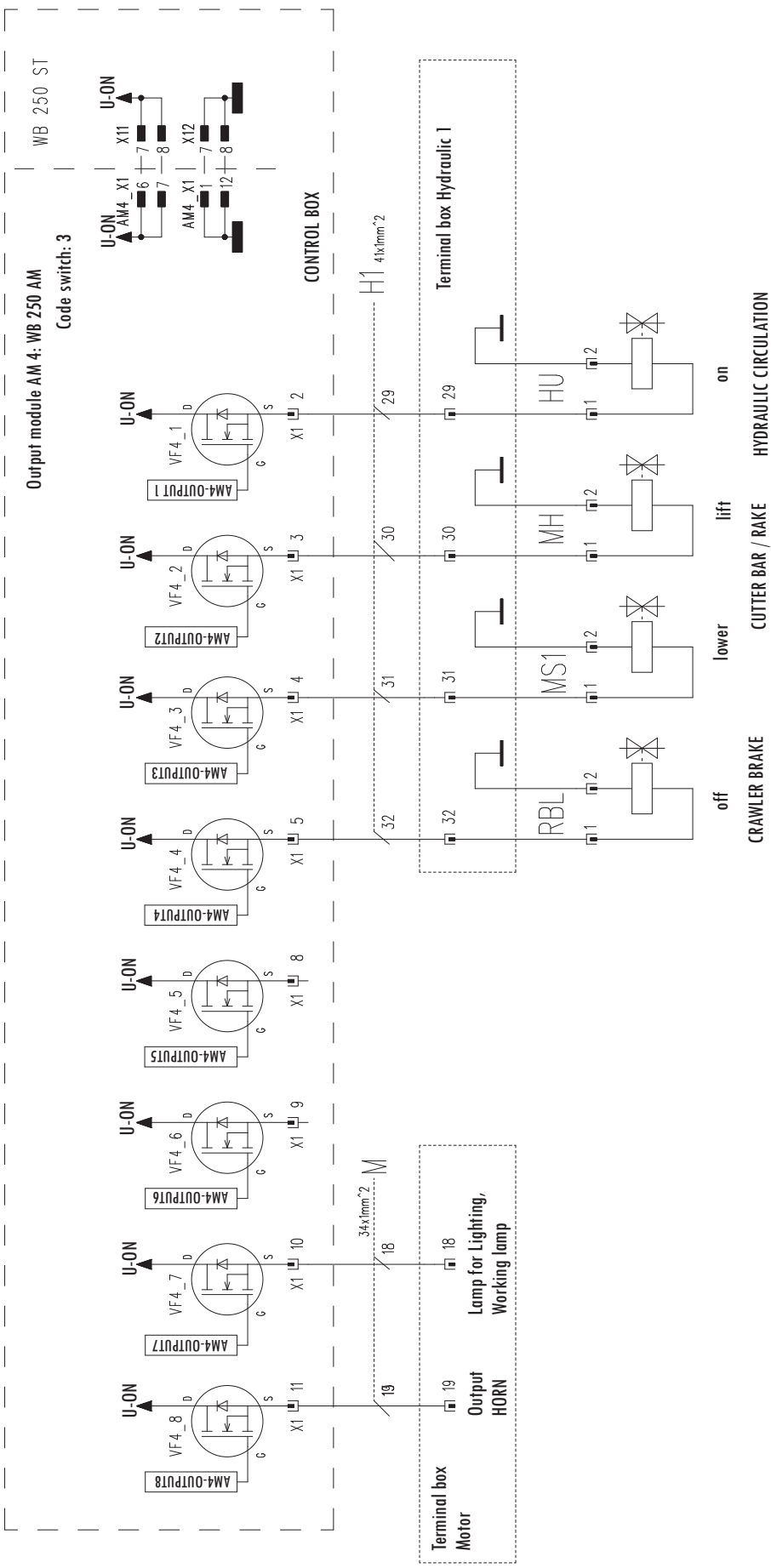

W. tronic 2600 V1.0
Schaltplan MZA Steuerung

Ariadne-CAD	Datum	Name
Bearbeitet	08.12.05	Endres L.
Geprüft:	Projekt: Willibald W. tronic 2600	
Projad./Filename: J:\W. tronic 2600\Ariadne Schaltplan\W. tronic 2600 V1.0.sch		

Zustand	Änderung	Datum	Name
V 1.1	V 1.2	06.12.07	Endres
V 1.2	V 1.3	29.07.08	Endres
V 1.3	V 1.4	26.11.09	Endres
V 1.4	V 1.5	19.05.11	L. Endr.
V 1.5	V 1.6	02.04.13	L. Endr.
V 1.6	V 1.7	18.09.13	L. Endr.
V 1.7	V 1.8	05.12.14	L. Endr.

Blatt-Nr. 10
Blattzahl 13

off CRAWLER BRAKE
lower CUTTER BAR / RAKE
lift HYDRAULIC CIRCULATION
on

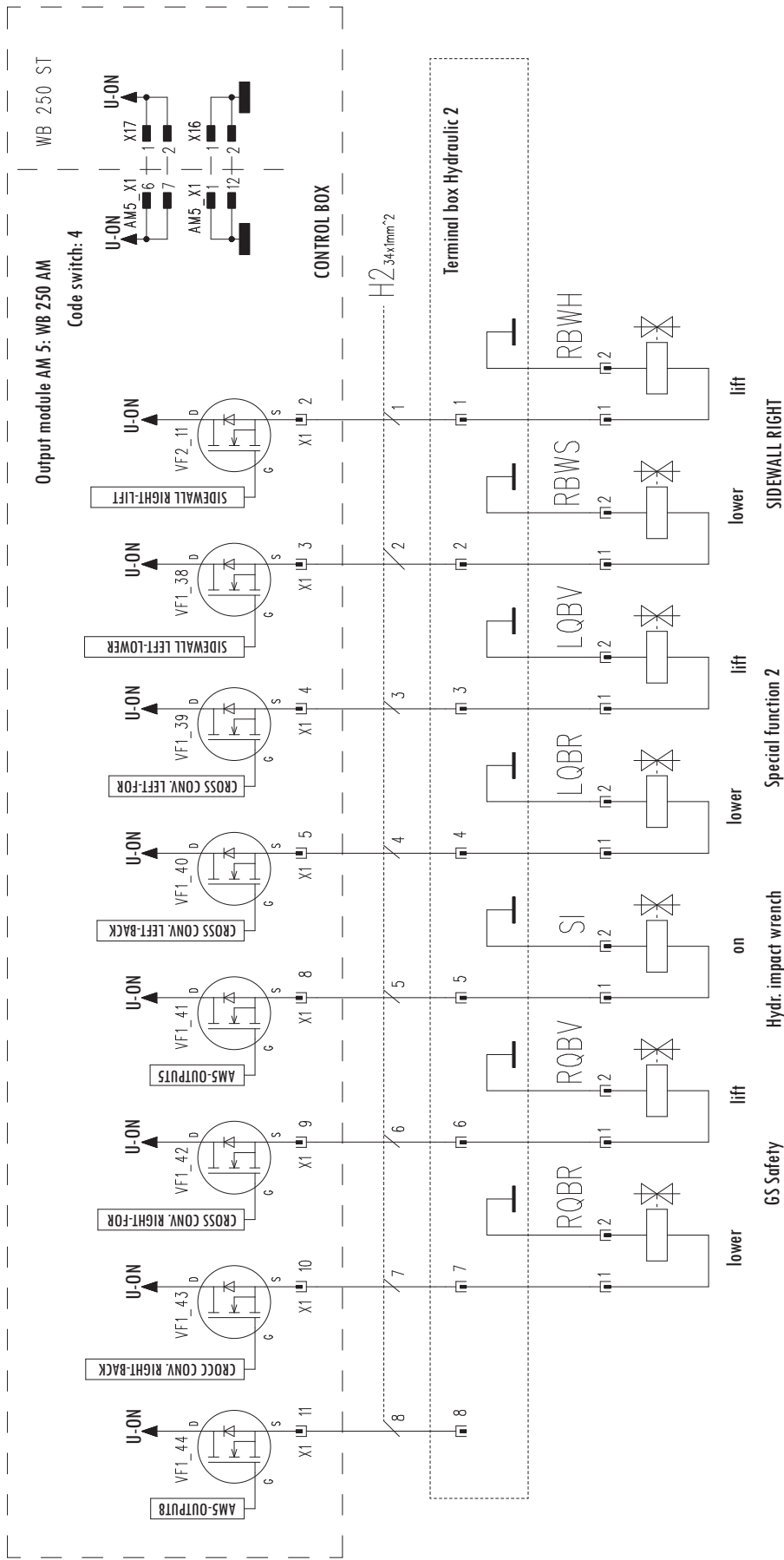

W. tronic 2600 V1.0
Schaltplan MZA Steuerung

Ariachne-CAD	Datum	Name
Bearbeitet	08.12.05	Endres L.
Projekt:	Projekt: Willibald W. tronic 2600	

Zustand	Änderung	Datum	Name
V 1.1	V 1.2	06.12.07	Endres
V 1.2	V 1.3	29.07.08	Endres
V 1.3	V 1.4	26.11.09	Endres
V 1.4	V 1.5	19.05.11	L. Endr.
V 1.5	V 1.6	02.04.13	L. Endr.
V 1.6	V 1.7	18.09.13	L. Endr.
V 1.7	V 1.8	05.12.14	L. Endr.

Blatt-Nr.	11
Blattzahl	13

Projod/FileName: J:\W. tronic 2600\Ariachne_Schaltplan\W. tronic_2600_V1.0.sch

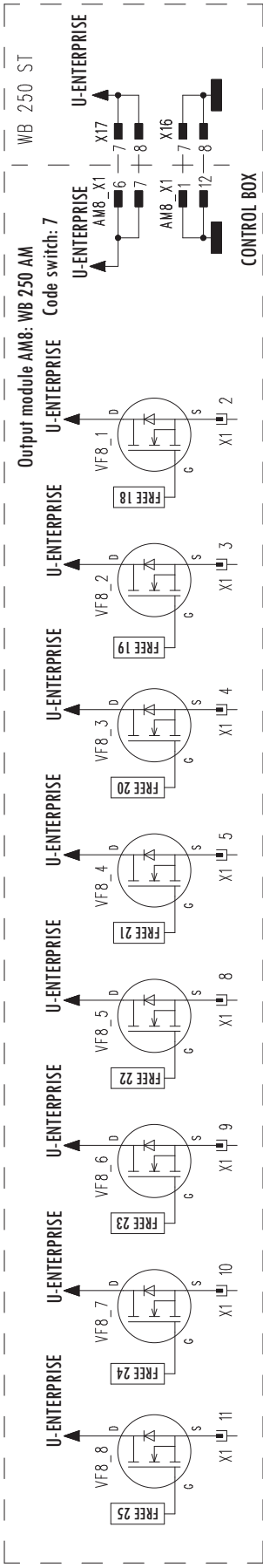
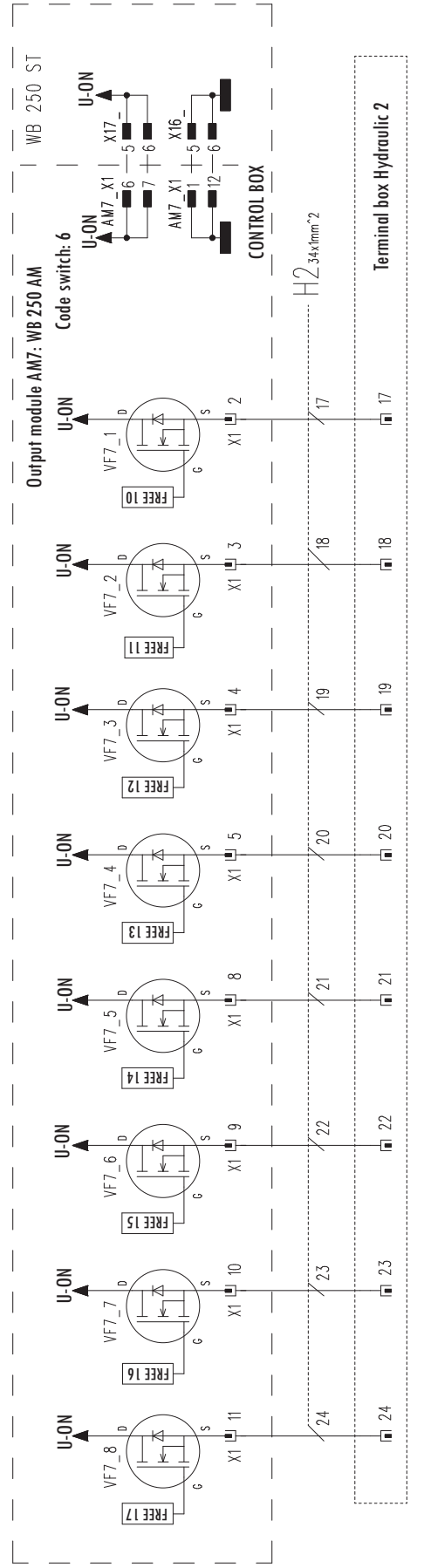
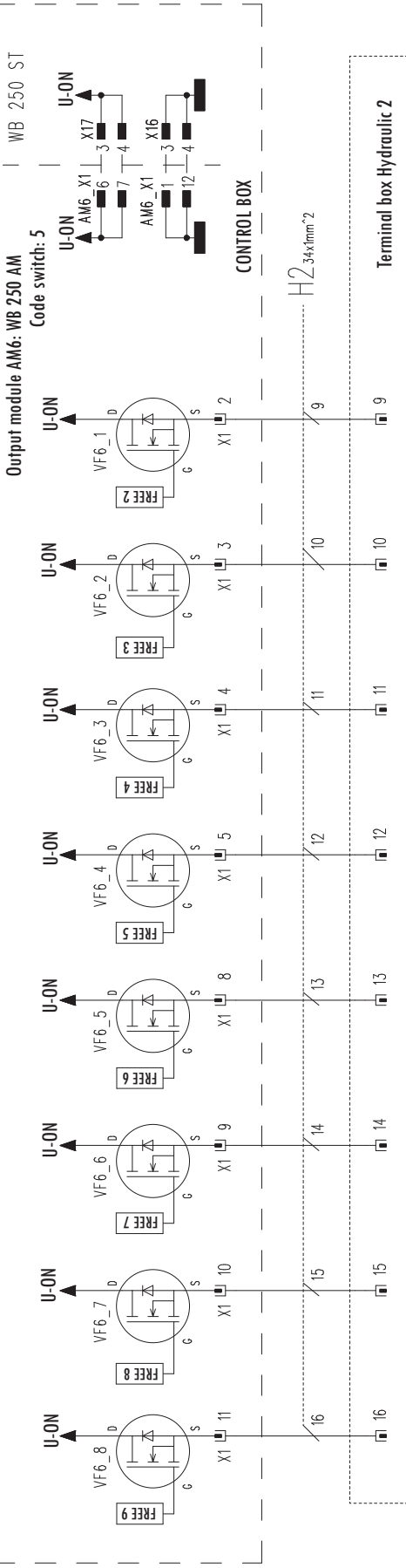

For Var. 50 = 2
Control box version V2.24.000
(OTHERWISE AMP7 - Module
Scheet 13)



W. tronic 2600 V1.0	
Schaltplan MZA Steuerung	
Ariachne-CAD	Name
Bearbeitet	Endres L.
Geprüft	Projekt: Willibald W. tronic 2600
Projed./Filename	J:\W. tronic 2600\Ariachne Schaltplan\W. tronic 2600 V18.sch

Blatt-Nr.	12
Blattzahl	13

Zustand	Änderung	Datum	Name
V. 1.1	V. 1.2	06.12.07	Endres
V. 1.2	V. 1.3	29.07.08	Endres
V. 1.3	V. 1.4	26.11.09	Endres
V. 1.4	V. 1.5	19.05.11	L. Endr.
V. 1.5	V. 1.6	02.04.13	L. Endr.
V. 1.6	V. 1.7	18.09.13	L. Endr.
V. 1.7	V. 1.8	05.12.14	L. Endr.

Shredding flap 0-10V Input
Rake flap 0-10V Input
Rotor-Clutch-Pulse
Rotor pulses

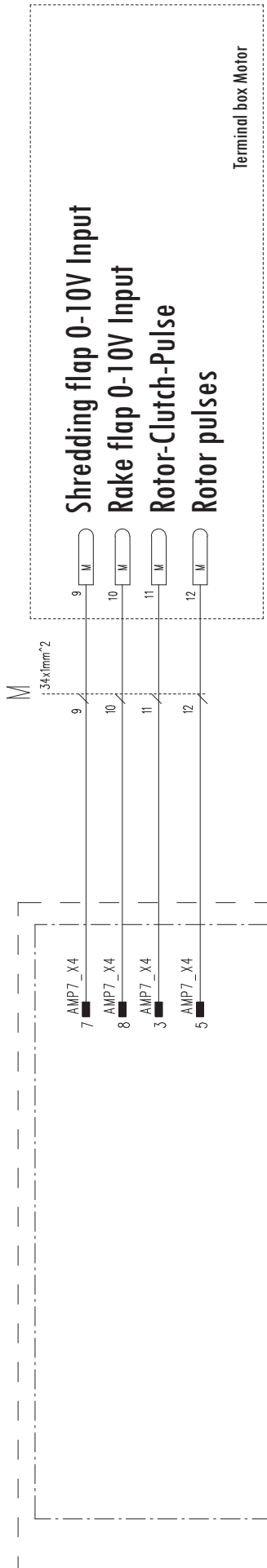

Terminal box Motor

CONTROL BOX

Control plate WB 250 ST

Output module AMP7: WB 250 AMP

Code switch: 6

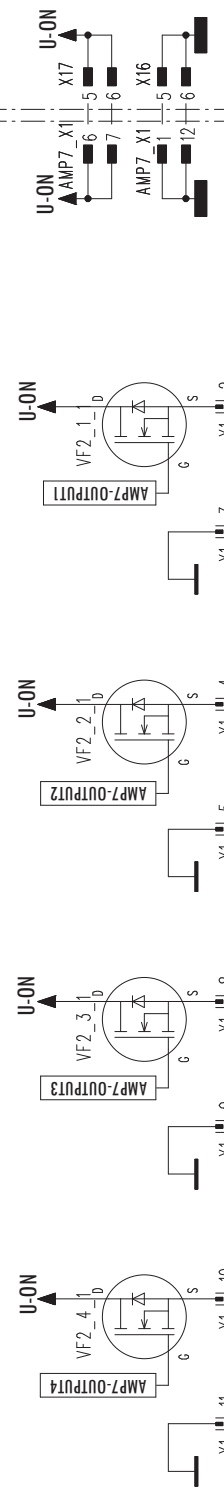

H1 4x1mm²

Terminal box Hydraulic 1

Valid for Var. 50 = 0 und 1
Control box from V3.00.000
with module AMP7

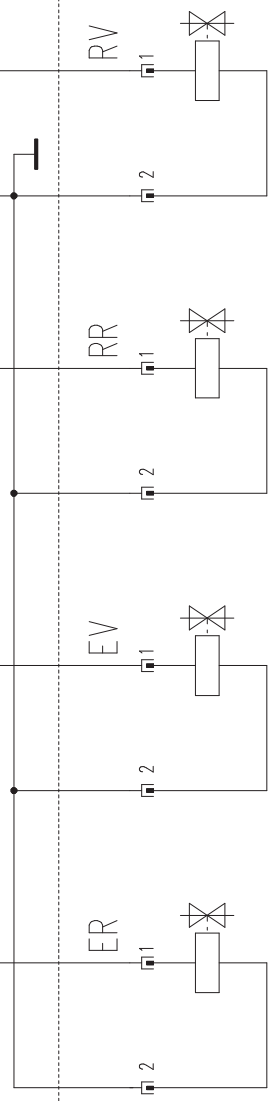

forward

backward

forward

backward

Endless floor

Infeed roller

forward

backward

forward

backward



W. tronic 2600 V1.0
 Schaltplan MZA Steuerung

Ariachne-CAD	Datum	Name
08.12.05	08.12.05	Endres L.

Projekt: Willibald W. tronic 2600
 Pfad/FileName: J:\W. tronic 2600\Ariachne Schaltplan\W. tronic 2600 V18.sch

Zustand	Änderung	Datum	Name
V 1.1	V 1.2	06.12.07	Endres
V 1.2	V 1.3	29.07.08	Endres
V 1.3	V 1.4	26.11.09	Endres
V 1.4	V 1.5	19.05.11	L. Endr.
V 1.5	V 1.6	02.04.13	L. Endr.
V 1.6	V 1.7	18.09.13	L. Endr.
V 1.7	V 1.8	05.12.14	L. Endr.

Blatt-Nr. 13
 Blattzahl 13

(ALTERNATIVELY module AM7, sheet 12)

6.0 COMMISSIONING / START-UP

6.1 Introduction

CAUTION

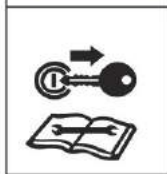

Thoroughly read and observe all information, warnings and safety notes contained in this operation manual *before* commissioning and start-up of the machine!

Keep this operation manual always ready to hand and, in case the machine is sold or ownership is transferred otherwise, make sure to pass it on to the new owner(s)!

Comply with all relevant rules and prescriptions operative and in force in regard to accident prevention by all means. Also make sure to comply with all generally acknowledged rules and prescriptions on safety technique, industrial medicine and road traffic.

Strictly observe the indicated servicing intervals!

You avoid accidents, dispose the machine ready for operation and have got the manufacturer's warranty.



DANGER

Drawing-in danger across moving endless floor and rotating infeed roll

Movable endless floor and rotating infeed roll can cause serious injury.

- Nobody must stay on the endless floor, when starting the motor!
- Make sure nobody stays within the danger zone (Illustration 2.2, Danger zones) of the EP 5500 Shark during maintenance work!
- Make sure that the machine can not be started by unauthorized persons!



DANGER

Danger of rolling away the EP 5500 Shark

The EP 5500 Shark weighs about 18 tons and when the machine is in motion unintentionally, can result in serious injury to death.

- Take care of approximately horizontal place!
- When commissioning the EP 5500 Shark, always make sure that EP 5500 Shark is secured against rolling away!





WARNING

Crushing hazard due to open and closed the hood!

Lowering the hood can result in serious injury to death.

- Nobody must stay in the danger zone during commissioning!
- No person must be at and under the hood when it is lowered!



DANGER

Danger due rotating rotor!

Danger caused from flying parts during working at the machine

The shredded and defibrated material, the caused by foreign bodies (for example stones) is thrown out of the EP 5500 Shark at very high speed!

- Nobody must come into discharge area of the EP 5500 Shark.
- Before starting the motor makes sure that there is no person between the rotor and discharge conveyor.
- Make sure nobody stays within the danger zone (Illustration 2.2, Danger zones) of the EP 5500 Shark when starting the motor!
- Make sure that nobody can succeed into the discharge area of the EP 5500 Shark when the machine is running!



DANGER



Drawing-in danger and crushing hazard due rotating idler roll and Power belt!

The drive motor brings the rotor in motion and the rotor rotates at very high speed, 1200 min⁻¹. Therefore, the pulley and power belts are protected with a fixed fairing.

No care these suggestions can have duty effects of health, till vital wound with and without death result.

- The motor must never be started, until on all protect parts for the power belt fixed are screwed.
- Make sure that the machine can not be started by unauthorized persons!





DANGER

Crushing hazard in area of discharge conveyor Danger of injury due moving discharge conveyor

Linearly moving parts can cause serious injury.



- During operation, no moving parts to interfere or tamper with moving parts.
- Make sure nobody stays within the danger zone (Illustration 2.2, Danger zones) of the EP 5500 Shark when starting the motor!
- Make sure that nobody can succeed into the discharge area of the EP 5500 Shark when the machine is running!

WARNING

Hearing loss from noise

The noise level of the EP 5500 Shark is approximately 83 dB (A).



NOTICE

During operation of the EP 5500 Shark has therefore always have suitable hearing protection must be worn.



CAUTION

Irritation of the eyes

Danger to your eyes because throwing out of the particles and due to increased production of dust while operating the EP 5500 Shark.



NOTICE

Always wear appropriate safety glasses, therefore!

6.2 Transport of the EP 5500 Shark

What is to be checked?

The following items must be assured, checked and controlled each time before driving on a public road:

Illustration 6.1

Transport EP 5500 Shark

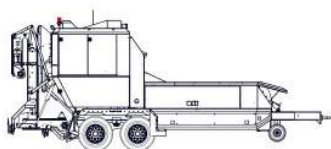

Transport position



1. Are the chassis and EP 5500 Shark at the licensing office registered?
2. Are the permissible trailer weight at the towing vehicle sufficient, in order to pull the EP 5500 Shark?
3. Has the EP 5500 Shark been coupled properly to the trailer coupling of the towing vehicle?
4. Is the trailer couplings ring in good condition?
5. Are the screws existing at the hitch of the EP 5500 Shark properly fixed and does not damage?
6. Are the two braking air hoses undamaged and correctly connected with the towing vehicle?
7. Are the plugs for the driving electrical connection put into the appropriate plug socket at the towing vehicle?
8. Is the discharge conveyor in transport position?
9. Is the lighting bar installed, and put and secured the pins for the lighting bar?
10. Does lighting, turn signal, brakes function?
11. Are the side flaps and sides doors right fixed?
12. Does the prescribed tire pressure exist in all 4 wheels?
13. Is the parking brake unlocked?
14. Is the wheel drive disengaged?

Illustration 6.2
EP 5500 Shark
Brake air distributor

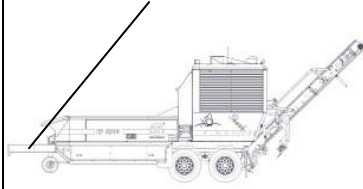

15. Is the button existing at the brake air distribution of the EP 5500 Shark pressed (position "open"). (Illustration 6.2) and is it engaged? It is assume, when wheel drive is checked.



Brake air distributor



WARNING

If the EP 5500 Shark of a towing vehicle without ABS is pulled or if the ABS at the towing vehicle or at the EP 5500 Shark is defective, must be counted during a danger braking on a longer stopping distance.

The total weight of the EP 5500 Shark will approximately 18 t and in such case the EP 5500 Shark needs to be equipped with an antiskid system for the operation brakes of the running wheels.

If the EP 5500 Shark is pulled by a towing vehicle, which is equipped with an ABS, the plug for the ABS must be put into the existing plug socket at the towing vehicle?

The efficiency of the ABS is indicated in the towing vehicle during a control light. If the ABS works correctly, this control light must expire at a speed of max. 10 km/h. If the light does not expire, a authorised workshop is to be visited.

It is permitted with a total weight over 13 tons a transport in connection with towing eye by 50 mm in diameter only!

Illustration 6.3
EP 5500 Shark
Start-up of the machine

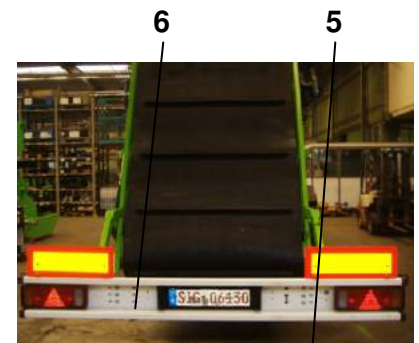
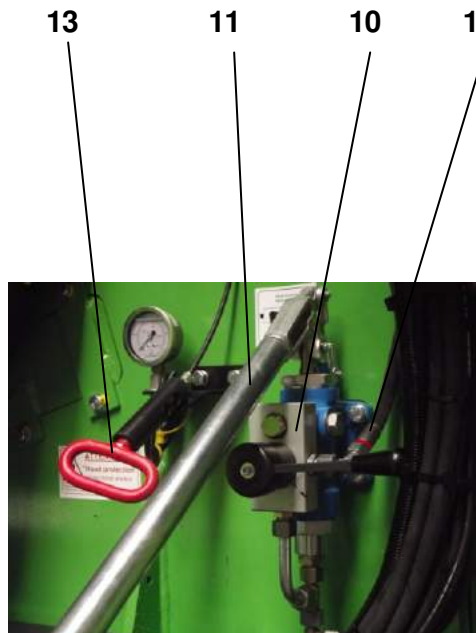
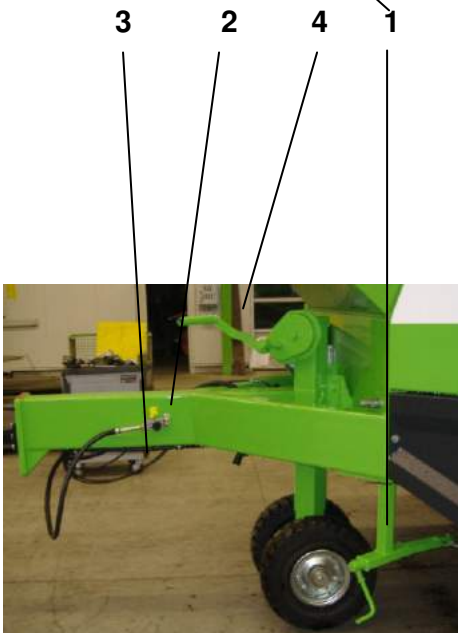
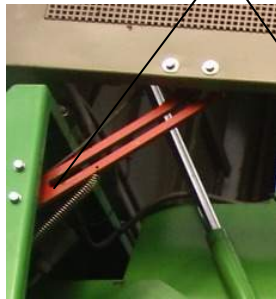
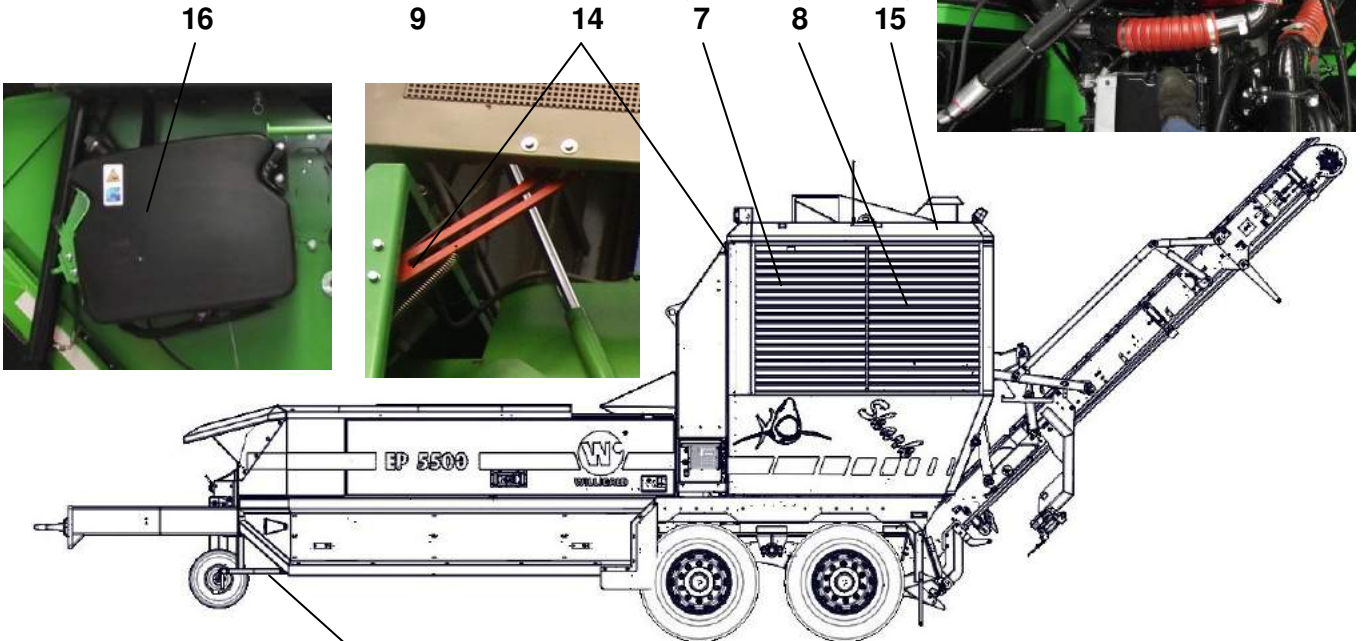
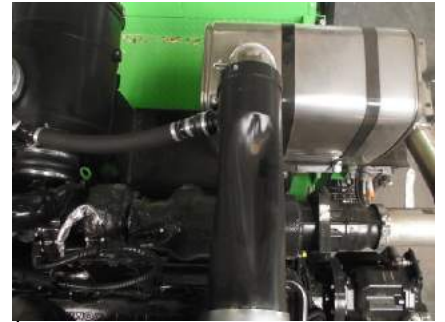

6.3 Start-up of the machine (Illustration 6.3)

6.3.1 Safety information



NOTICE

Read and observe the general safety and the safety instructions in this chapter before starting work.

The instructions must be followed and you must act cautiously to avoid accidents, personal injury and property damage.

The commissioning of the machine must be carried out by staff of WILLIBALD or by WILLIBALD trained personnel only.

WARNING



Danger of incorrect commissioning

Commissioning requires trained personnel with sufficient experience. Errors in the start-up can lead to life-threatening situations and lead to significant property damage with it.

- Commissioning is carried out by WILLIBALD employees.
- Also of WILLIBALD trained personnel should carried the commissioning with permission of WILLIBALD only.

6.3.2 Setting up the EP 5500 Shark

Pull the EP 5500 Shark to the provided operation place.

Take care of approximately horizontal place!

- Block the locking brake by turning the crank handle (1) clockwise.
- Disconnect and remove both brake lines (2) from the towing vehicle.
- Unplug all trailer cables (3) from the towing vehicle.
- Lower the wheel drive during turning the crank handle (4), that is no more necessary the trailer jack on the towing vehicle, alternatively during hydraulic wheel drive.
- Uncouple the EP 5500 Shark from the towing vehicle,
- Pull out the lighting plug (5), lighting bar (6) remains at the conveyor.

6.3.3 Motor hood opening



WARNING

Crushing hazard due to open the hood!

Lowering the hood can result in serious injury to death.

- No one must be in the danger zone during opening the hood!
- Do not carry out commissioning if the hood has not engaged in securing the hood.

Opening the hood occurs in the following steps:

1. Fold out discharge conveyor into the working position.
2. Switch at the hand pump (10) valve lever (12) downwards.
3. Pump up the hood with manual lever (11) until the hood is open complete.

Hood lifting /lowering over Hand pump



Bolt is not engage in the hood securing.

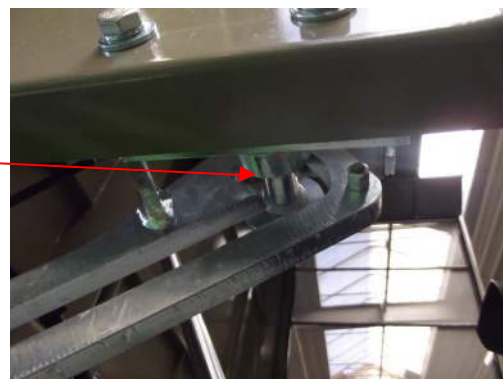

Switch valve level downwards



5. Switch the valve lever to right.
6. Then close the hood until the hood bolt in the hood securing (14) engages.

7. Switch the valve lever (12) back down.



Bolt is engage in the hood securing.



Switch valve level to right



The hood is completely opened and locked.

Filling socket 2



Level indicator 1

Check of hydraulic oil, engine oil level and fuel level before any operation. Refill hydraulic oil, engine oil, diesel fuel if necessary.

6.3.4 Checking the hydraulic oil level

Check the hydraulic oil level.

The level indicator (1) on the side of the hydraulic tank shows the hydraulic oil level. Oil level must lie between the markings "min." and "max". If the oil level is too low, (2) of hydraulic oil filling socket fill up until the "max." is reached (See chapter 8.7 types of oil).

WARNING

Fire hazard due to highly flammable hydraulic oil!

Hydraulic oil is inflammable!

Dirt accumulations in the motor compartment may lead to fire hazard and severe to fatal injuries.

- Fill hydraulic oil, when the motor is switched off only.
- Ensure cleanliness in the motor compartment. Cleaning is permitted with the switched off motor only.
- The hydraulic system should be checked before starting the motor for damage and leaks.



NOTICE

Extinguishing the warranty claims due to non-approved oils!

When using non-approved oils will extinguish the warranty claims. (See chapter 8.7 types of oil).

- Use the authorized fuels use only.

6.3.5 Checking the motor oil level

Check the motor oil level (8).

- Pull out the dipstick of the motor and wipe off that with clean rag.
- Insert the dipstick to the end stop again and pull out that again. Oil film on the dipstick must end between markings "min." and "max". If necessary, fill up with motor oil (see motor manual).



NOTICE

Component damage caused by overfilling

Motor damage can occur when filling of motor over the max-marking.

- Motor oil does not fill over the max mark on the dipstick.

6.3.6 Checking the diesel fuel level

Check the diesel fuel level (9).



WARNING

Fire hazard due to diesel fuel

Diesel fuel is inflammable!



- No smoking and no open fire when handling fuel.
- Refuel when the motor is switched off only.
- Ensure cleanliness in the motor compartment.
- Do not spill the diesel fuel.



The fuel level is seized by a float with resistance giver in the tank. The announcement of the control shows the current condition. ( Chapter 5.0 description W -Tronic 2600). A tank filling is enough for approx. 8-10 h.

6.3.7 Checking the coolant level

Closing cap



Check the coolant level (15).

- Unscrew the closing cap, that has no lead seal.
- The cooler is properly filled, when the refrigerant reaches up to the upper edge of the opening at the surge tank.

CAUTION



Risk of burns from hot surface or liquid

- Check coolant at a coolant temperature below 50 °C only!

6.3.8 Checking the AdBlue- System

Wenn the first commissioning, ensure that:

- AdBlue has a quantity of at least 15 liters in the tank.
- work area is clean and in order.
- coolant pipes, compressed air lines and carbamide lines are checked for sealing.

NOTICE



Component damage caused by overfilling

AdBlue freezes at temperatures below $-11\text{ }^{\circ}\text{C}$, and expands. Therefore, there is a risk of damage due to overfilling of the AdBlue tank.

- Do not overfill the carbamide tank (15).

6.3.9 Motor hood closing

WARNING



Crushing hazard due to close the hood!

Lowering the hood can result in serious injury to death.

- No person must be at and under the hood when it is lowered!
- Nobody must be stay in the danger zone at closing the hood.

Closing the hood occurs in the following steps:

1. Open the hood complete with hand pump, so that that is put out of the hood securing.

Valve lever shows downwards.



Switch valve level to right

2. Pull the red lever and turn the valve lever to the right.

Hood closes automatically.



7.0 OPERATION

General safety information

The operation of the machine must be performed by trained personnel or by professional staff only.

WARNING



Danger of incorrect operation

Improper operation can cause serious person or property damage.

- Make sure before starting work, all covers and safety devices are working properly.
- Never use safety equipment during operation except power.
- Ensure cleanliness and tidiness in the work area! Loosely superposed lying parts and tools are sources of accidents.

7.1 Starting, short description

DANGER



Danger of injury due moving parts

Linear motion components can cause serious or even fatal injuries.

- During operating, the machine must be monitored permanently and it may be turned away at short time only.
- Eye contact must exist always, when the moving pull up equipment is in use.
- Check, that nobody stays within the danger zones of the machine ( Illustration 2.2).

NOTICE



Danger due to incorrect starting

- See you W-tronic 2600 Quick reference.
- Check that there is nothing lies in the fill trough.
- The parking brake is light don, when building is not even!
- The wheels must still turn.

- Turn the key-code switch to the right. The plant is switched "ready for use". The announcement ENTERPRISE shines. Initialization waits for.

- Turn the key further: the starter is activated and the plant is turned on.

When the motor does not start, interrupts the starting procedure after maximally 20 seconds and repeat after approximately 1 minute.

- Let the motor run and warm up.

- Press the wheel drive.

- Activate key "**COUPLING ON**", announcement in display operates announces this procedure and wait to the rotor runs along (audibly).

Couple the rotor on and out with idling speed only!

- Wait 1 - 2 minutes till the coupling is engaged completely. One is depended from hydraulic oil temperature.

- The key **CRUSHING FLAP** - setting the desired particle size.

- The key **Numbers of revolution ADJUSTMENT** - setting desired speed, for example:

1900
1750.

- Press the key **DISCHARGE BELT FORWARD**. The discharge conveyor is switched into operating condition. Announcement in the display shows this procedure.

- Press the key **Numbers of revolution R.P.M. +** after completely coupling.

- Press the key **INFED ROLLER FORWARD**. The infeed roller is activated. Announcement in the display announces this procedure.

- Press the key **ENDLESS FLOOR FORWARD**. The endless floor is activated. Announcement in the display announces this procedure.

- Switch on the key **REMOUT CONTROL**. Announcement in the display announces this procedure.

Attention! Functioning may be operated during radio control on hand held transmitter only. Exemption: Emergency off.

- Feel with material.

WARNING



With operation the machine via radio control the operator must be able to the access the control panel, the located right side of the machine as well as the EMERGENCY-OFF switches provided at both sides of the machine (Illustration 2.2) at any time without any risks.

7.2 Adjustments (Illustration 7.1)

In feed roll, wheel drive, endless floor, discharge conveyor

There is control block on the left side of machine. On the control block there are the valves to adjust the speed of the draw-in roller, wheel drive, endless floor and discharge belt.

Turning it to the right will reduce the speed, turning it to the left will increase it. (Loose the catch for adjusting).

The endless floor conveyor is proportionally regulated.

The speed of the draw-in roller must be reduced if:

- the RPM protection often react,
- the material to be shredded is rather coarse and solid (e.g. wood, strong tree limbs, branches, bales of hay, humid grass etc.);
- the draw in roller is frequently running in inverse direction because the material to be shredded is too coarse or because the material heap on the endless floor is too high;
- the shredded material must have finer degree.

The speed of both heavy duty floor conveyor (endless floor) and draw-in roller can be increased if:

- the material heap is light crushed,
- the material heap on the endless floor is of minor height;
- the shredded material must have rougher degree.

If hood over control block is opened, the shut-off tap (13) beside hand pump (10) must to be closed.

Illustration 7.1

Valve for speed control of the infeed roller, wheel drive, endless floor, discharge conveyor

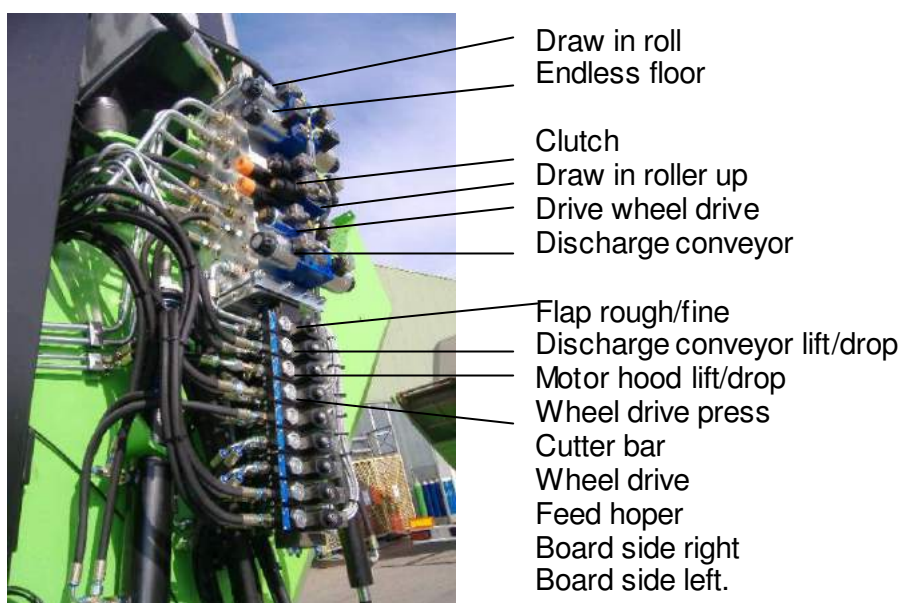
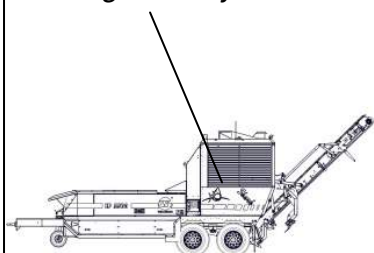

7.3 Turning out, short description



DANGER

Danger due rotating rotor!

The rotor will be running for several minutes after switching off the motor, and all dangers existing, when the motor is running will last on!

- Do not come into the draw-in and discharge area of the EP 5500 Shark.



Danger caused from flying parts during working at the machine

The shredded and defibrated material the caused by foreign bodies (for example stones) is thrown out of the EP 5500 Shark at very high speed!

- Nobody must come into discharge area of the EP 5500 Shark.
- Before starting the motor makes sure that there is no person between the rotor and discharge conveyor.
- Make sure nobody stays within the danger zone ( Illustration 2.2, Danger zones) of the EP 5500 Shark when starting the motor!
- Make sure that nobody can succeed into the discharge area of the EP 5500 Shark when the machine is running!

Turning out

- ( Chapter 5.0, Description W-Tronic - 2600)
- If possible, let the EP 5500 Shark continue to work until the complete heavy duty floor conveyor (endless floor) is empty.
- When it is impossible, switch the endless floor over to **BACKWARDS MOTION** and switch the infeed roller over to **BACKWARDS MOTION** too, and let the EP 5500 Shark continue to work, until the rotor does no more slides at the shredded material. *Audible! Do not look for it!*
- Switch the **ENDLESS FLOOR** and **DRAW-IN ROLLER** keys over to **OFF ("AUS")** position.
- Press the **MOTOR R.P.M.** key (**r.p.m. (-)**) provided on the control pad (no load running). This condition is signalled by display.
- Switch the **COUPLING** keys over to **OFF ("AUS")** position. This condition is signalled by display.
- Switch the **DISCHARGE CONVEYOR** key over to **OFF ("AUS")** position. This condition is signalled by display.
- Activate the **STOP** key. The plant switches to the OFF state. This condition is signalled by display.

7.4 Emergency-off function

Several **EMERGENCY-OFF push buttons** have been provided at the machine. If one of these buttons was pushed, the motor will be stopped immediately and all hydraulic drives are taken out of service (Chapter 5.0, Description W-Tronic - 2600).

Motor and power belts are very strong charged, when the EP 5500 Shark switched off with EMERGENCY-OFF push button. EMERGENCY-OFF push buttons may therefore be activated in an emergency case only and must not be used for normal switch-off.

Such, the following emergency cases could occur:

- Imminent danger that persons might get into the pull in and discharge area of the EP 5500 Shark or on the endless floor conveyor.
- Danger that material which - by reason of its size, nature and structure - cannot be defibrated, might get caught by the draw-in rollers (e.g. big stones, metallic objects etc.)

*Illustration 7.2
V-belt protection is closed*



and locked with a lock



7.4.1 Press back the idler roll

After an emergency stop can the idler roller stay engaged.

For pressing the idler roller back:

Switch on ignition.

Run the motor briefly.

When motor is running, the rotor turns and the idler roller is pressed back by itself. In this case, the V-belt protection must be closed and locked. (Illustration 7.2)

If, after an emergency stop, the motor cannot run, (for example, if the rotor is blocked), the following steps are necessary to restart:

- Eliminate a cause for the emergency.
- Idler roller must be relieved.

For this work the V-belt protection must be opened.

DANGER



Danger due to restarting by unauthorized persons!

Drawing-in danger across V-belts!

Ignoring this safety information can have heavy effects of health, till vital wound with and without death result.



- Make sure that the machine can not be started by unauthorized persons!
- Perform maintenance work when the machine is stopped only.
- Motor must not be started with engaged idler roller!

Next Steps:

- Open the motor hood over the hand pump,
- Open the protection door of the V-belts,
- Examine, that the hydraulically operated idler (clutch) is pressed and the power belts are completely relaxed. If this is not the case, the idler must be pressed with the help of a lever with switched on ignition upward
- Closed the protection doors of power belts.
- Start the EP 5500 Shark, proceed as described in Chapter 7.1, "Starting".

Illustration 7.3: Idler roll (1) is released, hydraulic cylinder (2) is completely to back repressed, the power belts are released

Illustration 7.3
EP 5500 Shark
Coupling

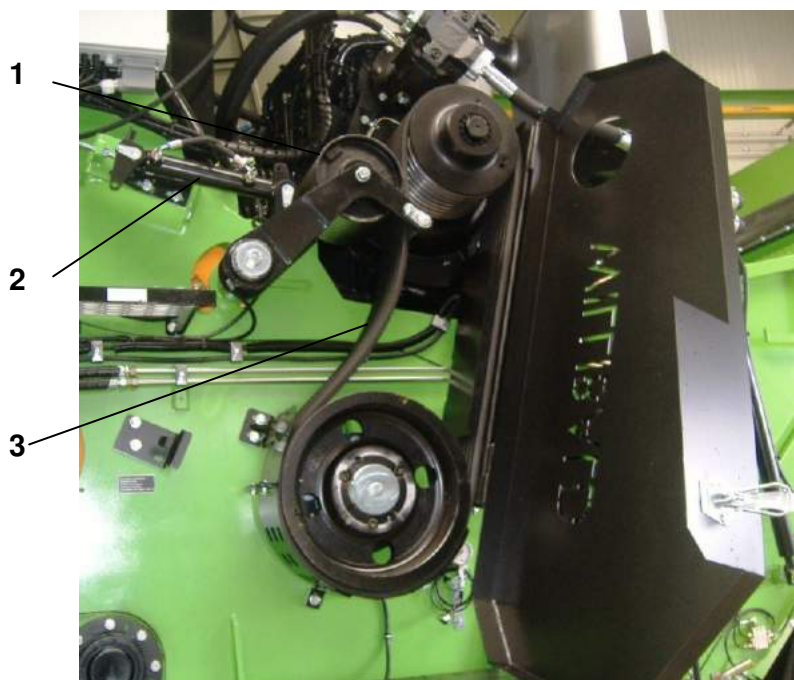
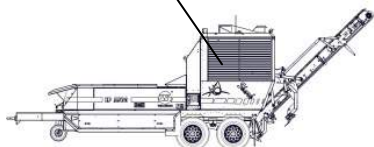

7.5 Transfer of machine

7.5.1 Machine without wheel drive

DANGER



Danger caused from flying parts during working at the machine

The shredded and defibrated material the caused by foreign bodies (for example stones) is thrown out of the EP 5500 Shark at very high speed!

- No persons must stay in the danger zones ( Illustration 2.2)!
- Nobody must come into discharge area of the EP 5500 Shark.
- Before starting the motor makes sure that there is no person between the rotor and discharge conveyor..

At its latest, the EP 5500 Shark must be transferred, i.e. driven away from the new formed compost windrow by some meters if the rotor starts scraping the new formed up windrow or if the windrow reaches the same height as of the discharge belt.

For this purpose, the EP 5500 Shark motor must not be turned off (stopped) (i.e. infeed roller, endless floor conveyor and discharge conveyor: STOP); however, it is recommended to reduce the motor r.p.m. down to no-load speed.



DANGER

Danger of rolling away the EP 5500 Shark

The EP 5500 Shark weighs about 18 tons and when the machine is in motion unintentionally, can result in serious injury to death.

- When transferring the EP 5500 Shark, always make sure both towing vehicle and EP 5500 Shark are protected against wheeling away!
- Use the Willibald wheel wedges to prevent rolling the machine.



- Couple the towing vehicle to the EP 5500 Shark.
- Protect the towing vehicle against rolling away.
- Release the locking brake of the EP 5500 Shark.
- Tow the EP 5500 Shark away from the compost heap by approx. 1-2 metres.
- Block locking brake of the EP 5500 Shark.
- Uncouple the EP 5500 Shark from the towing vehicle.

7.5.2 Machine with wheel drive



DANGER

Danger caused from flying parts during working at the machine

The shredded and defibrated material the caused by foreign bodies (for example stones) is thrown out of the EP 5500 Shark at very high speed!

- No persons must stay in the danger zones (Illustration 2.2)!
- Nobody must come into discharge area of the EP 5500 Shark.
- Before starting the motor makes sure that there is no person between the rotor and discharge conveyor..

At its latest, the EP 5500 Shark must be transferred, i.e. driven away from the new formed compost windrow by some meters if the rotor starts scraping the new formed up windrow or if the windrow reaches the same height as of the discharge belt.

For this purpose, the EP 5500 Shark motor must not be turned off (stopped) (i.e. infeed roller, endless floor conveyor and discharge conveyor: STOP); however, it is recommended to reduce the motor r.p.m. down to no-load speed.



DANGER

Danger of rolling away the EP 5500 Shark

The EP 5500 Shark weighs about 18 tons and when the machine is in motion unintentionally, can result in serious injury to death.

- When transferring the EP 5500 Shark, always make sure both towing vehicle and EP 5500 Shark are protected against wheeling away!
 - Use the Willibald wheel wedges to prevent rolling the machine.
- Couple the towing vehicle to the EP 5500 Shark.
 - Protect the towing vehicle against rolling away.
 - Release the locking brake of the EP 5500 Shark.
 - Fold away the wheel drive.



But there are two possibilities: over switchgear cabinet or over radio. (See Chapter 5.0 W-Tronic 2600).

Disengaging the wheel drive: First press the grey release key: Display message: „Decontrol for releasing traction drive” than activate within 3 seconds the key for releasing the wheel drive.

Transfer the machine on the desired place now.

Clap the wheel drive again and work with machine as usually: motor is full throttle, draw in roll, endless floor and discharge belt on.

Engaging the wheel drive: Press the key, until the wheel drive is completely engaged.

7.6 Turning of the EP 5500 Shark, start of new compost, windrow forming procedure



DANGER

Danger of rolling away the EP 5500 Shark

The EP 5500 Shark weighs about 18 tons and when the machine is in motion unintentionally, can result in serious injury to death.

- When transferring the EP 5500 Shark, always make sure both towing vehicle and EP 5500 Shark are protected against wheeling away!
- Use the Willibald wheel wedges to prevent rolling the machine.

A new compost windrow can now be stratified and formed. Before doing so, make sure to comply with all information, notes and danger sources indicated in Chapter 6.0 "Commissioning". Regarding the execution of the steps listed above, please observe Chapter 7.5.1.

- Couple the towing vehicle to the EP 5500 Shark.
- Release the locking brake of the EP 5500 Shark.
- Move the machine to another compost windrow.
- Block locking brake of the EP 5500 Shark.
- Uncouple the EP 5500 Shark from the towing vehicle.



7.7 Replacement of wear parts



WARNING

Danger of injury by improper replacement parts

Incorrect or faulty spare parts can cause damage, malfunction or failure and impair safety.

- No parts other than original **WILLIBALD** spare parts must be used to replace worn off wear parts. If otherwise, we cannot guarantee for the proper functioning and operating safety of the unit
- Before performing any of the works described in Chapter 7.7, make sure the motor is turned out and the main battery switch is in OFF position ( Illustration 3.1).

By changing the wearing parts discharge conveyor must be brought into the maintenance position.

DANGER



Danger of crushing in all maintenance and repair work!

By maintenance work discharge conveyor must be brought into the maintenance position.

There are a free space between crushing unit and discharge conveyor at maintenance position. When the hydraulic cylinders come in motion, is occurred mortal danger to human life.

- No one is allowed to stay in the danger zone ( Illustration 2.2 danger zones), as long as the discharge conveyor is moving!
- Do not perform maintenance and repair work without securing of the discharge conveyor cylinder.



7.7.1 Taking the discharge conveyor in maintenance position

Transport position



*Function
„Conveyor lift / lower“*



1. Take the discharge conveyor from the transport position to in the work position;

2. Select the function “Conveyor lift / lower, lift the conveyor

Intermediate position



Work position



Arm fix with bolts

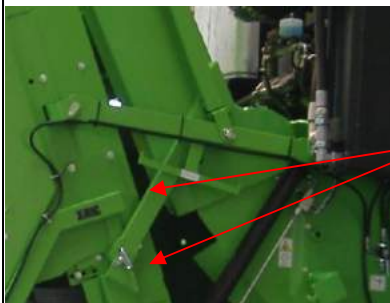

3. Attach the parallel arm into position and fix with bolts;



4. Open and pull out the linch pin;

5. Remove the bolt;

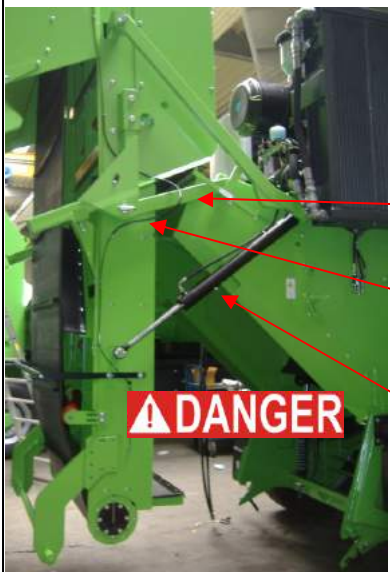

Control danger area, nobody may stay in danger area!

Parallel arm

Bolts

Hydraulic cylinder

Function „Conveyor lift / lower“



6. Select the function "Conveyor lift / lower"

7. Lower the discharge conveyor

CAUTION



Collision danger!

Caution! Press the button until the discharge belt has reached the vertical position only!

If the discharge belt is moved over the vertical position also, then touching the belt, the hood and it can cause damage!

A red marker will appear on the crushing unit. This means the end of the discharge conveyor movement.

Red marking

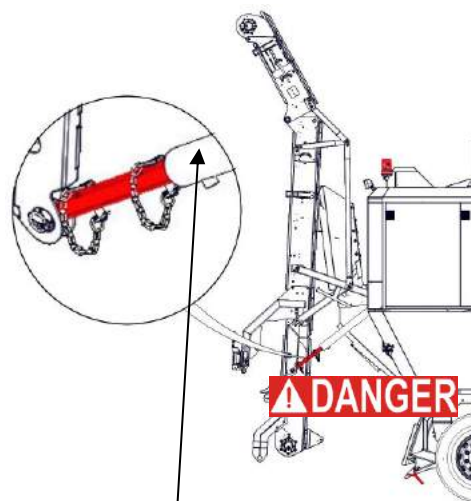

Hydraulic cylinder

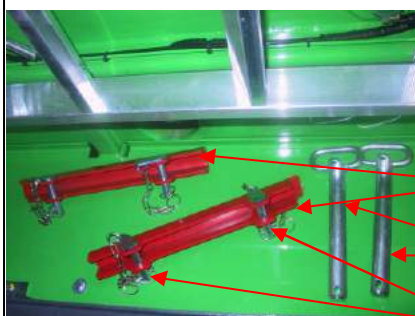

Position: 50 % moved out, discharge conveyor is vertical.

Position > 50% Collision danger

U-Profile (support rod)

Bolts

Linch pin

*Cylinder securing both sides
Bolts are inserted and with
linch pin secured*



8. Attach the U-Profile (Support rod) on both sides to the piston rod of hydraulic cylinder and secure with bolts and linch pin

The maintenance work can be begun, when cylinder securing is appropriate to both hydraulic cylinders of the discharge belt only, for example replacement of wear parts!

Illustration 7.4
Drive off border of flail

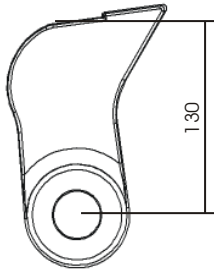

7.7.2 Replacement of flails

Imbalance leads to vibrations of the rotor. The with a wear below the driving off border of 130 mm of the flail turning point flails (illustration 7.4) lead to excessive energy expenditure and wear of the rotor, up to the imbalance. Therefore the flails must be changed with reaching the driving off border.

Danger by replacement of flails



DANGER

Danger due rotating rotor!

Danger caused from flying parts!

The rotor will be running for several minutes after switching off the motor, and all dangers existing, when the motor is running will last on!

- Do not come into the draw-in and discharge area of the EP 5500 Shark!
- Machine parts touch only when they are stopped completely.

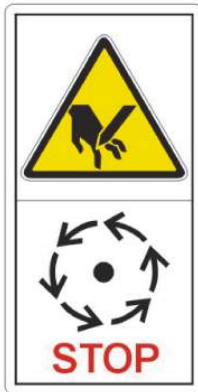

WARNING

Danger of crushing in all maintenance and repair work!

Danger of imbalance of the rotor!

The rotor is no longer balanced if the plug-in shaft is removed by pulling it out. The rotor will turn! For all maintenance and repair work without coupling securing the rotor, one could start to move and cause serious injury.



Coupling securing

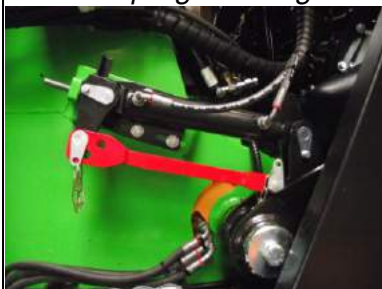

Securing of conveyors cylinder



- Perform maintenance and repair work when the machine is stopped only.
- Before performing any maintenance or repairs the coupling cylinder must be secured with securing rod and bolts.
- Before performing any maintenance and repair work both band cylinder must be secured with support rod and bolts.
- Replace the flails always in sets.
- When replacing them, comply with the prescribed mounting directions.

*Illustration 7.5
Unscrew the cover plate*

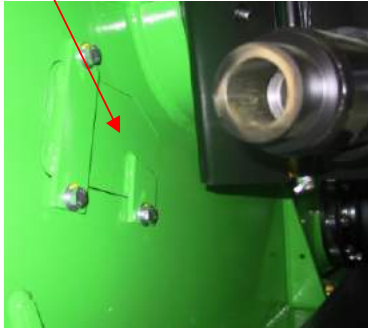

Threaded hole



*Illustration 7.6
Remove the securing screw 3*

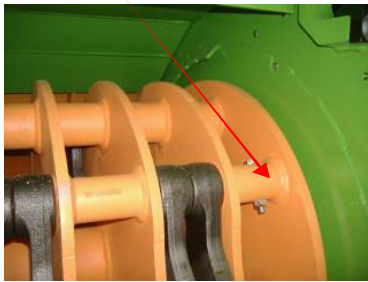

Illustration 7.7



Illustration 7.8



The manual exchanging the flails

The flails can be manual or with hydraulic shaft pulling device (as extra option) exchanged.

1. Preparing the machine

- Let the EP 5500 Shark continue to work until the complete endless conveyor floor is empty.
- Tow the EP 5500 Shark away from the compost windrow by approx. 5 m.
- Open the hood and check that hood is engaged in hood securing.
- Crushing flaps drive upward and basket drive downwards.
- Bring the discharge conveyor in maintenance position.
- Turn the motor out.
- Turn the main battery switch "OFF" ("AUS"), (Chapter 7.3, Turning out, short description).
- Unscrew the cover sheet underneath of the rotor bearing (Illustration 7.5)
- Unscrew the safety screw (3) on the rotor plug-in shaft. (Illustration 7.6).

- Turn the rotor till a thread hole provided in the plug-in shaft becomes visible in the opening underneath of it.
- Clean the thread hole.

2. Remove old flails

- Screw tightly the guide bar (2) into the thread hole. (Illustration 7.7).

- Beat with the striking weight (1) the plug-in shaft from the rotor (Illustration 7.8).

Illustration 7.9



The flails fell to the lower basket (Illustration 7.9).

Illustration 7.10



3. Insert new flails

- Introduce the guide bar and the greased plug-in shaft again into the rotor and cautiously knock it in using the striking weight. (Illustration 7.10).
- Gradually, let your assistant slip the new flails in pairs onto the plug-in shaft.
- Make sure to comply with the prescribed mounting direction!

4. Insert next flails

- Screw the safety screw into the plug-in shaft again tightly.
- Screw the guide bar out off the plug-in shaft and turn the rotor until the next thread hole in the opening becomes visible;
- Now replace the flails as described here above.
- Screw the cover sheet (Illustration 7.5) down again underneath of the rotor bearing.
- Remove the securing of cylinders;
- Bring the discharge conveyor into work position.
- Turn main battery switch "ON" ("EIN").
- Turn the motor on.

Illustration 7.11

Examine the free run of the flails



- Switch on the rotor; examine the free run of the flails (Illustration 7.11).

- If everything is correct, switch off the machine.
- Close the hood.

The exchanging the flails with hydraulic axle extractor

Illustration 7.12
Hydraulic axle extractor



1. Preparing the machine

- Let the EP 5500 Shark continue to work until the complete endless conveyor floor is empty.
- Tow the EP 5500 Shark away from the compost windrow by approx. 5m.
- Open the hood.
- Start the machine.
- Bring the discharge conveyor into work position.
- Crushing flaps drive upward and basket drive downwards.
- Turn the motor out.
- Turn the main battery switch "OFF" ("AUS"), ( Chapter 7.3, Turning out, short description.
- Unscrew the cover sheet underneath of the rotor bearing (Illustration 7.5)

2. Safety measure

Coupling securing



- Bring the securing rod on clutch cylinder and secure with bolts,
- Close the belt protection.
- Block the crushing flap during ball cock.

Securing of conveyors cylinder



- Attach the support rod over hydraulic cylinders of discharge conveyor and secure with bolts and linch pin.

3. Remove old flails

Illustration 7.13
Fold out the pulling device



- Fold out the pulling device. (Illustration 7.13).
- Unscrew the auf der Steckwelle entfernen (Abbildung 7.6).

Illustration 7.14

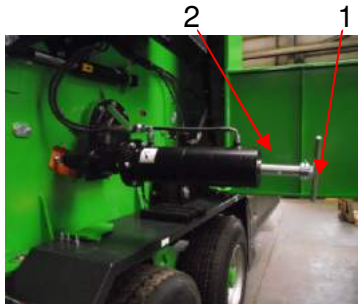

- Screw tight the auxiliary shaft (2) with the swing (1). (Illustration 7.14).
- Motor on; stand gas, rejust the panel on funk.

By distant control may be use the function “Crushing flap” or “Stop” only.

- During simultaneous pushing the “Crushing flap” on the radio control and opening hydraulic plug on the cylinder of one person, can be the shaft bit by bit pull out.

Illustration 7.15
Insert the distance sleeve



- After one full stroke come back the cylinder and apply the distance bush (3) and pull again. (Illustration 7.15).

- Screw out the auxiliary shaft after 3-Th bush; rescrew the swing (1) on the shaft.

- Pull out the plug-in shaft with the same step as the auxiliary shaft only.
- Motor Stop.
- Take out the plug-in shaft from pulling device, clean that, use possibly again.

4. Insert new flails

Two distance sleeves



- Fold on side the shaft pulling device.
- Built the new flails in pairs with one person.
- When replacing them, comply with the prescribed mounting directions.
- Screw the safety screw again.
- Repeat all step from the point “Fold out the pulling device” until all flails are exchanged.
- Motor Stop.

Three distance sleeves



- After changing the flails fold off the pulling device on side and screw that again.
- Screw the cover sheet on the light side of rotor again.
- Open the V-belt protection, delete the securing rod on the clutch cylinder, and close the V-belt protection.
- Open the crushing flap during ball cock.
- Motor on, stood gas.
- Turn the rotor on, check the free running of flails.
- If everything is correct, switch off the machine.
- Remove the securing of conveyors cylinder.
- Bring the discharge conveyor into work position.
- Close the hood.

The manual exchanging the flails by Rotor with 32 flails

Illustration 7.16
Rotor with 32 flails



Illustration 7.17
Flails

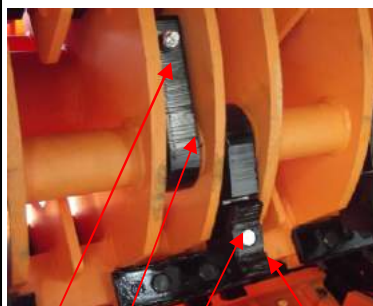

3 1 4 2

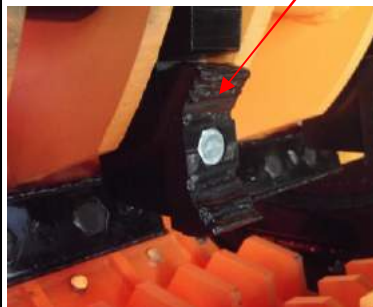



Illustration 7.18
Examine the free run of the flails



1. Preparing the machine

- Let the EP 5500 Shark continue to work until the complete endless conveyor floor is empty.
- Tow the EP 5500 Shark away from the compost windrow by approx. 5m.
- Open the hood.
- Start the machine.
- Bring the discharge conveyor into work position.
- Crushing flaps drive upward and basket drive downwards.
- Turn the motor out.
- Turn the main battery switch "OFF" ("AUS"), ( Chapter 7.3, Turning out, short description.

2. Exchanging the tools

The flail consists of the main body (1), the exchange peak (2), the screws (3) and nut (4). Illustration 7.17

The exchange peaks reach the driving of border faster than flail main body and must be replaced.

The exchange peaks are replaced manually without pulling out the plug-in shaft.

- Turn the rotor manual and unlock the screws and nuts from tools;
- Exchange the exchanging peaks;
- Tighten the screw with torque 300 Nm

If the tools are changed, then:

Open the V-belt protection, delete the securing rod on the clutch cylinder, and close the V-belt protection.

- Open the crushing flap during ball cock.
- Motor on, stood gas.
- Turn the rotor on, check the free running of flails. Illustration 7.18
- If everything is correct, switch off the machine.
- Remove the securing of conveyors cylinder.
- Bring the discharge conveyor into work position.
- Close the hood.

3. Exchanging the flails completely

When the main body of the flails are worn, the plug-in shafts must be pulled out. See description exchanging the flails with 48 und 40 tools

7.7.3 Replacement the rakes of crushing basket

WARNING



Danger of crushing by changing the rakes!

The rakes of crushing basket located in the catchment area of the machine, where are the infeed roller and rotor. If these parts come in motion, can be result in serious injury or even death.

- Replacement the rakes when the machine is stopped only.
- Make sure that the machine can not be started by unauthorized persons!
- Lift the infeed roller high hydraulically and secure with bolt.

Infeed roller securing



Securing of conveyors cylinder



- Bring the discharge conveyor into maintenance position.
- Secure both discharge conveyor cylinders with support rod and bolts.

CAUTION

Danger of falling down of heavy rakes

The rakes weigh approximately 60 kg and if that falls, accidents can happen.

- Rakes should be by an assistant or a forklift removed from the machine.
- Secure the rake against falling down with ropes.



Screws

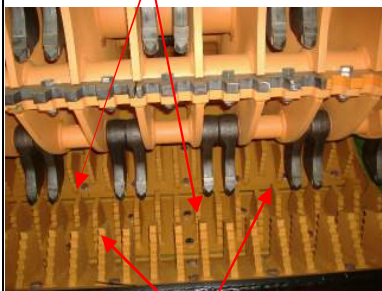

Rakes
Nuts

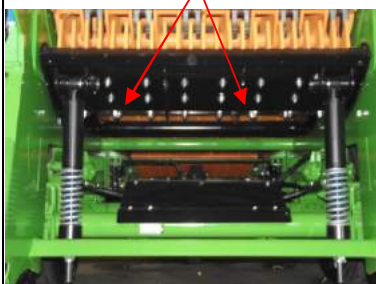

Rakes are changed according to the following steps:

- Turn the motor out;
- Turn the main battery switch "OFF".
- Loose the screw and nuts of changing rakes;
- Assistant with forklift removes the rake;
- Insert new rake and tighten slightly the screw.
- Turn the rotor slightly and examine the free run of the flails;
- Adjust the rake with the flails (move left or right).
- Tighten the screws finally;
- Remove the securing of conveyors cylinder.
- Bring the discharge conveyor into work position.
- Turn the rotor on, check the free running of flails again;
- Drive up the crushing flap;
- The machine is ready for operation.
- Check the screws for 5-10 hours for tightness.

7.7.4 Replacement of the shredding flap



DANGER

Crushing hazard due to discharge conveyor by replacement the shredding flap!

By replacement the shredding flap discharge conveyor must be brought into the maintenance position. Trained person must work in the danger zone. Without security of conveyor cylinders occurs deadly threat to human life.

Danger zone by replacement of shredding flap



Securing of conveyors cylinder

- Replacement the shredding flap when the machine is stopped only.
- Make sure that the machine can not be started by unauthorized persons!

- Bring the discharge conveyor into maintenance position.
- Secure both discharge conveyor cylinders with support rod and bolts



Shredding flap is changed according to the following steps:

- Turn the motor out;
- Turn the main battery switch "OFF".

Crushing flap consists of two segments which are fastened with 6 screws (in each case 3 screws).).

Screws



- Loose the fixing screws;
- Remove the segments;
- Screw new segments;
- Tighten the screws finally;
- Remove the securing of conveyors cylinder;
- Bring the discharge conveyor into work position;
- The machine is ready for operation.

7.7.5 Replacement of power belt

DANGER



Drawing-in danger and crushing hazard due rotating idler roll and Power belt!

The drive motor brings the rotor in motion and the rotor rotates at very high speed, 1200 min⁻¹. Therefore, the pulley and power belts are protected with a fixed fairing.

No care these suggestions can have duty effects of health, till vital wound with and without death result.



- The motor must never be started, until on all protect parts for the power belt fixed are screwed.
 - Perform maintenance work when the machine is stopped only.
 - Make sure that the machine can not be started by unauthorized persons!
- Power V-belt is changed according to the following steps:

*Illustration 7.19
EP 5500 Shark
Replacement of power belt*



- Open the motor bonnet and secure it ( Chapter 6.3.3, Motor hood opening).
 - The motor is turned out; the rotor stopped and stands still.
 - The main battery switch must be turned "OFF".
- Caution! The parts are weighty!
- Open and unhook the protective case (1), before parts be unscrewed.
 - Mark the place.

- Unscrew the lower belt protection (2).
- Loose the V-belt protection (3).
- Loose and pull out the screw (4).
- Hanging out the clutch cylinder.
- Press back the idler roll.
- Remove the used old power belts and fit new belts.
- Turn down the idler roll again.
- Screw the lower belt protection (2) and (3).
- Sling the coupling cylinder again.
- Check the distance between power belts and belt protection.
- Sling and close the protection flap (1). Make the trial run.
- Unsecured and close the motor hood.

Take care the power belt does run absolutely well. It must not graze at the belt guides!

7.8 Fault indications at the control



WARNING

Danger of injury due to improper disposal of fault indication

Improper disposal of fault indication can caused serious personal injury and property damage.

- Perform all maintenance work when the machine is stopped only.
- The main battery switch must be turned "OFF".
- No persons must stay on the endless floor conveyor or within the discharge area of the EP 5500 Shark!

Warning signals

Fault / malfunction	Possible reason	Possible defect	Remedy
Indication „Motor hot“	Cooler clogged, grating		To be cleaned
		Temperature sensor	Contact the client phone service
Indication „No load“	V-belt		Check, v-belt generator, To strain
		V-belt	Replace the V-belt
		Electric generator	Contact the client phone service
Indication „Fuel empty“	Fuel almost empty		Refill
		Fuel giver	Contact the client phone service

Emergency stop signals

Fault / malfunction	Possible reason	Possible defect	Remedy
Indication „Overheating“	Cooler polluted		Clean it using a broom
		Temperature sensor	Contact the client phone service
		Cooler	See indication „Cooling water“
Indication „Lack of oil“	Motor oil level too low		See motor manual. Contact the client phone service
Indication „Cooling water“	Cooling water level too low		Refill cooling water, check both cooling water hose and cooler for leakages and replace it, if necessary
		Sensor	Contact the client phone service
Indication „Air filter“	Preliminary filter clogged (mushroom type)		Clean it using a brush and compressor air
	Air filter strongly polluted	Replace	Need to be cleaned, beat the air filter cartridges out or clean them otherwise
		Pick-up	Contact the client phone service
Indication „Overheating“ Hydraulic oil	Oil filter polluted	Pick-up	Clean it using compressed air
Indication „Hydraulic oil level to low“	Hydraulic oil level too low	Pick-up	Refill hydraulic oil

7.9 Service diagnosis / Fault finding table

Fault / malfunction	Possible reason	Remedy
Draw-in roller or endless floor cannot be deactivated and com to Stop under low load or start running in reverse sense	Motor hot	Cooler strongly contaminated (needs to be cleaned)
		Transmitter defect (to be replaced)
	Low r.p.m. level set too high	(Contact the client phone service) correct the adjustments
	Material jammed up (endless floor, draw-in roller, discharge belt)	(Caution!: unit must be in „OFF“ condition, check and remove jammed up material, if necessary
	Hydraulic oil filter contaminated (oil motors come to Stop at low load)	Replace filter
	Respective pressure switch defectively	Check, (Contact the client phone service) replace
	Control block defective (doesn't switch off)	To check it, switch the valves above the control block manually. If there is no reaction, the control block must be replaced (Contact the client phone service).
	Oil motor defective (endless floor, draw-in roller, discharge come to Stop at low load)	Replace the oil motor. Check the hydraulic pressure.

Fault / malfunction	Possible reason	Remedy
Low r.p.m. protection doesn't respond or pilot lamp shows light constantly	Low r.p.m. protection not properly set	(Contact the client phone service) adjust the low r.p.m. protection
R.P.M. meter indication does not react	Check the corresponding sensor	Check, probably increase tension or replace it
Rotor bearings get hot	Dirt between rotor face and unit side wall or bearing defective, bearing defect, no lubrication	Check the rotor cleaner plates front-side, clean the spaces in-between or replace the cleaner plates, check the bearing and replace it, if necessary
Rotor doesn't turn	Power belts defective	Check and replace, if necessary (set by set)
	Coupling doesn't engage	See malfunction "Coupling engages"
	Rotor frozen up (winter)	Warm it up in a warm room
Coupling doesn't engage	Throttle valve misadjusted	(Contact the client phone service) check and correct the adjustments, if necessary
	Solenoid valve defective Solenoid defective	(Contact the client phone service) check and replace, if necessary
	Safeguard on the control defective	(Contact the client phone service) check and replace, if necessary
	Control fuse blown or defective	(Contact the client phone service) replace

Fault / malfunction	Possible reason	Remedy
The discharge belt stops, moves backwards or permanently changes its movement direction	Discharge belt jammed	Check the discharge conveyor for foreign debris, remove the foreign debris Contact the client phone service
	Pressure switch off defect	
Endless floor moves heavily or comes to stop	Cleaning worm clogged	Needs to be cleaned
	Endless floor clogged	Needs to be cleaned
Radio control doesn't work. Motor stops	Operator is in the radio shadow Remote control not charged (i.e. accumulator empty)	Change operator position Check, if necessary, recharge accumulators
Machine vibrates strongly	Flyweight in the rotor	Check if the flails are wearing out and check if they are complete. Replace flails, if necessary
Rotor produces loud noises	Flails not properly mounted	Check, correct and set straight, if necessary (see Chapter 7.7..1: Replacement of flails)
	Counter blades warped	Check and repair, if necessary
	Machine stands in extremely uneven position	Always make sure the machine is levelled horizontally
Motor does not reach full r.p.m. or runs sputtering	Fuel filter clogged	Clean the fuel filter, replace it, if necessary
		E Pump defective. Safeguard
	No fuel	Refill fuel
	Ad Blue Feed faulty	AdBlue Check system AdBlue Replace Filter Obtain help from manufacturer's service department

8.0 MAINTENANCE

WARNING



Danger of injury due to improper maintenance

- Perform all maintenance work on the EP 5500 Shark when the motor is stopped only.
- Make sure that the machine can not be started by unauthorized persons!
- The main battery switch must be turned "OFF".
- No persons must stay on the endless floor or in the discharge area of the EP 5500 Shark with running motor!

While on duty, the EP 5500 Shark is exposed to strong mechanic strain and to strong production of dust. Moving parts of the unit must be serviced at short intervals, therefore. Regular servicing improves and significantly extends the EP 5500 Shark operating ability.

All greasing points are marked red. Press such a quantity of grease in till it emanates from the bearings to be greased. Thereby, the contaminated and used grease is pressed out of the bearing point together with the condensed water accrued there ( Chapter 8.8, Grease types).

Timely replacement of worn parts maintains the EP 5500 Shark readiness for operation and contributes significantly to maintain its operational safety.

After the first 10 service hours, check all screws and bolts for tightness and from that point on check them each day and retighten them, if necessary.

The maintenance intervals indicated are based on a daily one-shift operation of the EP 5500 Shark.

Information in regard to fuel and cooling agent can be learned from a separate instruction manual issued by the motor producer.

NOTICE



For the maintenance of the drive motor is the separate operating instructions for the engine manufacturer's instructions.

This must be performed by an authorized service center.

Details for the lubrication can be found in the separate operating instructions of the manufacturer.

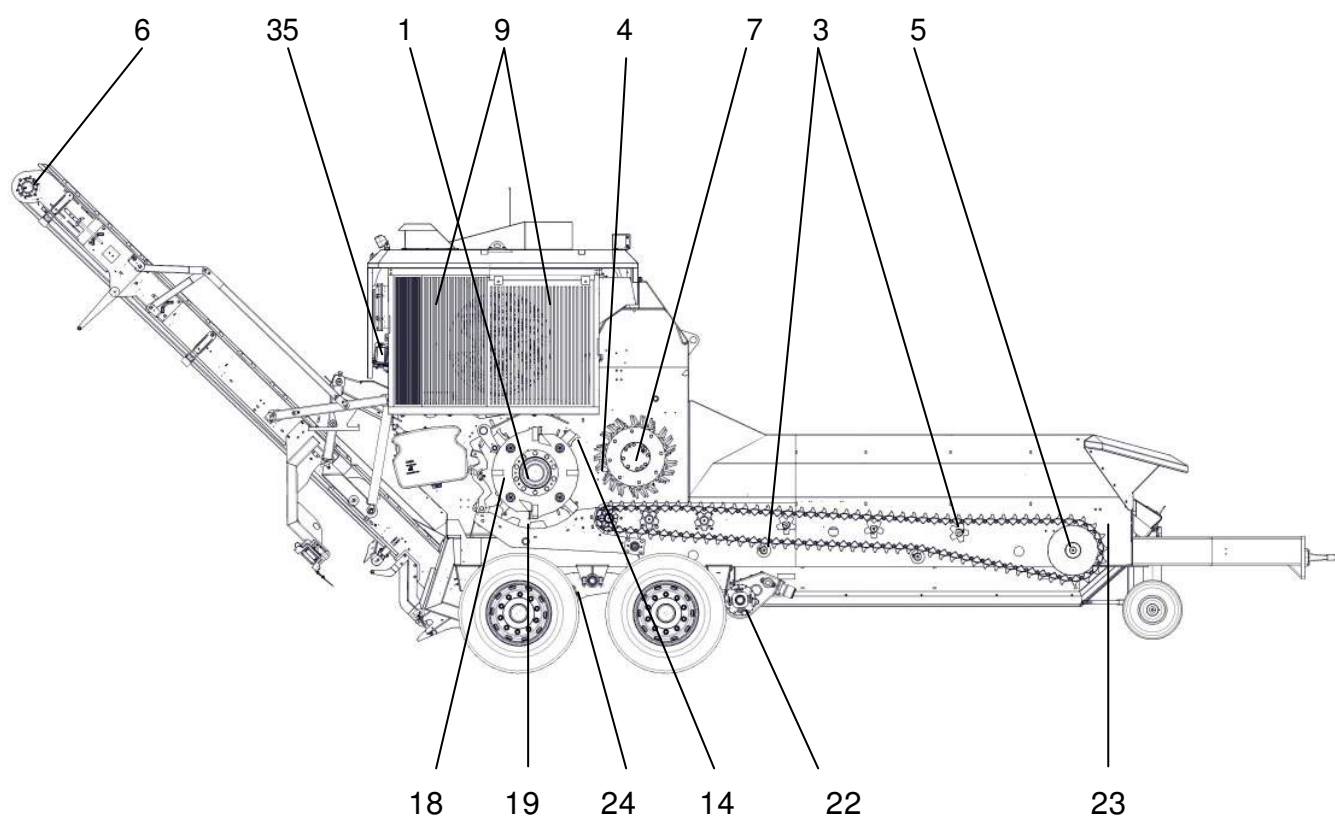

Illustration 8.1

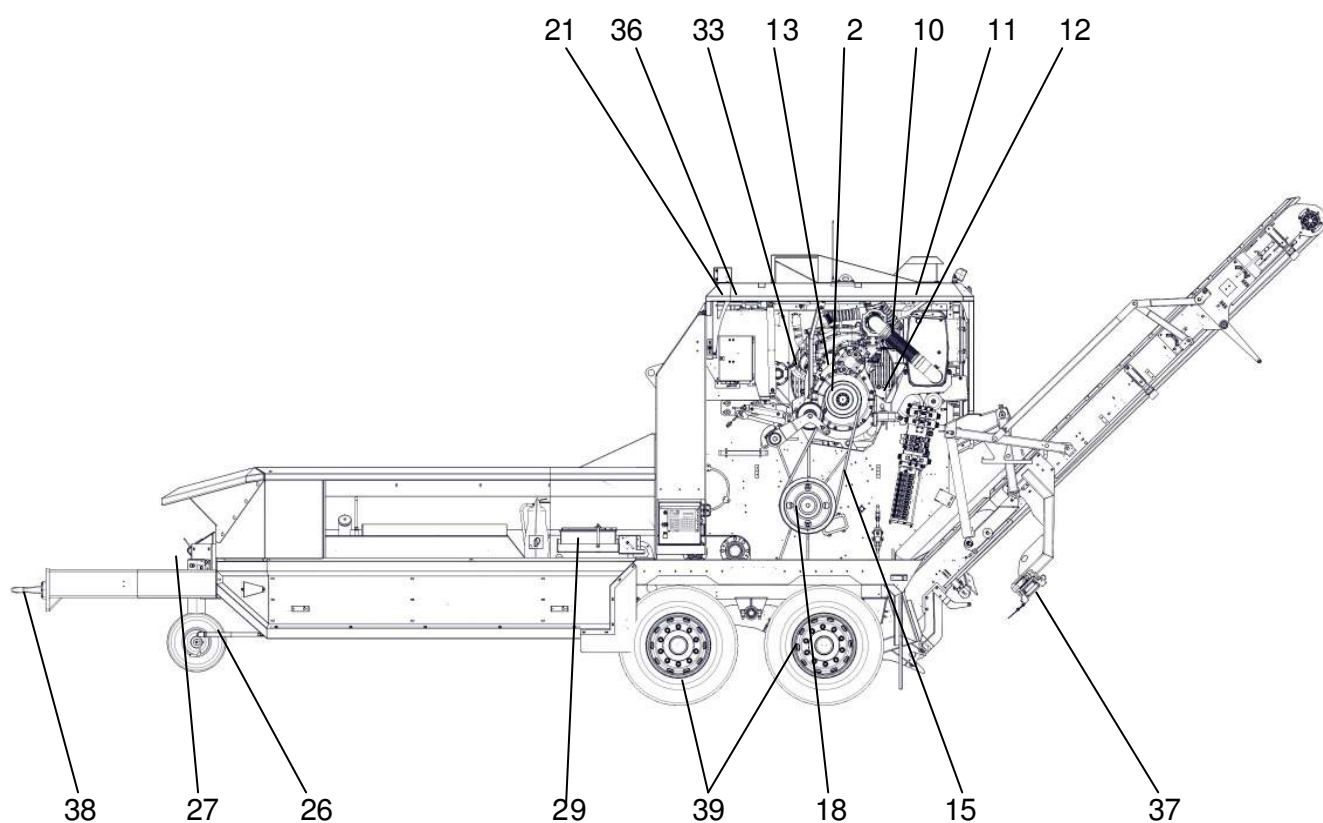

Illustration 8.2

8.1 Lubrication plan (Illustrations 8.1 and 8.2)

No.	Service points	What must be done?	Process materials, tools	Maintenance intervals
1	Rotor bearing	Grease at both sides, approx. 2-3 grease gun strokes will suffice	Roller bearing grease, grease gun	2 x each day
2	Motor output	To be greased, low quantity will suffice, approx. 1 grease gun press stroke	Roller bearing grease, grease gun	2 x each day
3	Endless floor guides	Grease all carrying shaft bearings left and right side	Roller bearing grease, grease gun	Each day
4	Drive cage	To be greased at both sides	Roller bearing grease, grease gun	Each day
5	Reversing worms	To be greased at both sides	Roller bearing grease, grease gun	Each day
6	Discharge belt	To be greased left and right side	Roller bearing grease, grease gun	Each day
7	Bearing of the draw-in rollers	To be greased	Roller bearing grease, grease gun	Each day
8	Magnetic drum	Lubricate the bearing	Roller bearing grease, grease gun	Each day
9	Cooler and oil cooler	Visual control, remove eternal dirt accumulations or pollutions, if necessary	Hand broom, compressed air	each day, probably several times each day
10	Air filter	Check for pollutions and clean it, if necessary	Compressed air	Each day, (depending on material)
11	Preliminary filter	Make visual controls and clean in case of contamination	Brush, compressed air	Each day, (depending on material)
12	Oil level indicator (dip stick) motor	Check oil level, refill motor oil, if necessary	Motor oil in compliance with the oil type prescribed	Each day
13	Motor	Clean	Pressure air	Each day probably several times each day
14	Tools / flails	Visual control, flails, scraper must be replaced two by two if worn strongly	Striking weight	Each day

8.2 Other maintenance works (Illustration 8.1 und 8.2)

No.	Service points	What must be done?	Process materials, tools	Maintenance intervals
15	Main drive belt (power belt)	Visual control, replace two by two if damaged, check the belt tension (with uncoupled rotor, the clamping cylinder (back pressure rollers) must not be run out completely. If this was the case, the clamping cylinder must be dislocated downwards and the holding fork be readjusted.		Each day
16	Store tank of the central lubrication system	To be filled	Roller bearing grease, grease gun	Control each day (inspection glass)
17	Screws and bolts	Check for tightness		Service or as need be each day
18	Rotor	Visual control, check the lateral scrapers and replace, if necessary		Each day
19	Rakes / Basket	Visual control, replace at the strong wear		Each week
20	Rubber belt, discharge conveyor	Check the rubber belt of damage and run.		Each week
21	Exhaust connection for the hydraulic oil	Must be cleaned (blown out)	Compressed air	Each week
22	Wheel drive	Grease the bearing at both sides	Roller bearing grease, grease gun	Each week
23	Endless floor tension	The endless floor may be by switching off drive max. 5 cm sag, otherwise must be the endless floor left and right equable restretch. Is the swing reach, may the endless floor during taking out several links shortening.		Each month

No.	Service points	What must be done?	Process materials, tools	Maintenance intervals
24	Springs and brake levers on the axes	To be greased	Roller bearing grease, grease gun	Each month
25	Drainage valve on brake air boiler	Condensation blow out		Each month
26	Parking brake crank	To be greased	Roller bearing grease, grease gun	Each month
27	Sustainers crank	To be greased	Roller bearing grease, grease gun	Each month
28	Wheel drive gear Draw-in rollers, endless floor, belt gear	Check oil level and refill, if necessary make an oil change	Control plug, (inspection glass)	Each month 1 x after 500 hours and all 2000 hours from there on
29	Battery	Control the battery acid level. (refill, if necessary)	Distilled water	By service
30	Shackles	Control screws and bolts, retighten, if necessary (important with wheel drive)		By service
31	Cooling agent	Control the antifreeze compound	Water, antifreeze compound pursuant to the indications issued by the motor producer	By service For winter
32	Oil change including oil filter change on the motor	To be performed by an authorized workshop of the motor producer		Consider the date of motor producer. 1 x after 100 hours and all next 400 hours
33	Fuel filter	Replacement of filter		1 x after 100 hours and all 400 hours from there on
34	AdBlue filter cartridge	Must be replaces		All 500 hours
35	Hydraulic filter cartridge	Must be replaces		1 x after 100 hours and all 400hours from there on.
36	Hydraulic oil change			1 x after 500 hours and all 2000 hours from there on
37	Lighting	Operational test		Each time before using public roads
38	Trailer coupling ring	Visual control, replace warped or broken coupling ring and check if is well seated and control if all fastening screws and bolts are in perfect condition		Each time before using public roads
39	Tyres	Check tire pressure (8.5 bars) and tire profile. Pump or replace		Each time before using public roads. as required

8.3 Replacement of the trailer coupling ring

Replace the trailer coupling ring when that has becomes warped. When changing it, replace the spring lock washer, too. Use 10.9 screws with torque.

8.4 Replacement of the brake lining

If the brake linings have reached their wear limits, must be replaced in an authorized workshop.

8.5 Changing of the wheels



DANGER

Danger of rolling away the EP 5500 Shark

When the EP 5500 Shark unintentionally set in motion, it can result serious or even fatal injuries.

- Secure the EP 5500 Shark against rolling away with wheel wedges.
- To change the wheels, the EP 5500 Shark can be lifted at the axis.
- Tighten wheels with torque.





8.6 Hydraulic oil change

NOTICE

Extinguishing the warranty claims due to non-approved operating supplies!

When using non-approved operating supplies will extinguish the warranty claims.

- Use the authorized fuels use only.
- Make sure to comply with the instructions of the respective hydraulic oil producer when replacing mineral oil by bio oil or vice versa.
- Before replacement of the complete hydraulic oil, please contact our service department. ( Chapter 8.10, Service addresses)

For maintenance works or service routines to be performed at the motor and for refilling of hydraulic oil, use the hand pump to open the motor hood. ( Chapter 6.3, Commissioning).

Before replacement of the complete hydraulic oil, please contact our service department. ( Chapter 8.10, Service addresses)

After 5 - 10 service hours check all screwed connections of the hydraulic system for tightness and retighten them, if necessary.

Make sure to comply with the instructions of the respective hydraulic oil producer when replacing mineral oil by bio oil or vice versa.



8.7 Recommended hydraulic oil types

Producer	Oil type HLP/Type name	Viscosity in mm ² s at 40 °C
ARAL	Vitam GF 46	40-50
ARAL	Vitam GF 68	60-80
AVIA	Fluid RSL 46 M	40-50
AVIA	Fluid ZAD 46 M	40-50
AVIA	Fluid RSL 68 M	60-80
BP	Energol HLP HM46	40-50
BP	Bartan 46	40-50
BP	Bartan SHF-S46	40-50
BP	Energol HLP HM68	60-80
BP	Bartan 68	60-80
CASTROL	HYSTIN AWS 46	40-50
CASTROL	Paradene 46 AW	40-50
CASTROL	HYSTIN AWS 68	60-80
CASTROL	Paradene 68 AW	60-80
CHEVRON	Hydraulic Oil AW 46	40-50
CHEVRON	Hydraulic Oil AW 68	60-80
ESSO	NUTO H 46	40-50
ESSO	Hydraulic Oil HLP 46	40-50
ESSO	NUTO H 68	60-80
ESSO	Hydraulic Oil HLP 68	60-80
FUCHS	RENOLIN MR 15 VG 46	40-50
FUCHS	RENOLIN B 15 VG 46	40-50
FUCHS	RENOLIN ZAF 46 B	40-50
FUCHS	RENOLIN MR 20 VG 68	60-80
FUCHS	RENOLIN MR 68 MC	60-80
FUCHS	RENOLIN B 20 VG 68	60-80
FUCHS	RENOLIN ZAF 68 B	60-80
MOBIL	Mobil DTE 25	40-50
MOBIL	Mobil DTE Excel 46	40-50
MOBIL	Mobil DTE 26	60-80
MOBIL	Mobil DTE Excel 68	60-80
SHELL	Shell TELLUS 46	40-50
SHELL	Shell TELLUS DO46	40-50
SHELL	Shell TELLUS S 46	40-50
SHELL	Shell TELLUS 68	60-80
SHELL	Shell TELLUS DO 68	60-80
SHELL	Shell TELLUS S 68	60-80
MEQUIN	Mequin HVLPD46	22-46
MEQUIN	Mequin HVLP68	68
MOTOREX	Focus QTM SAE 10W/40	
MOTOREX	Gearoil Universal SAE 85W/140	
MOTOREX	Gear Compound Plus	
MOTOREX	Corex HV 68	
MOTOREX	Corex HVLP-D 46	

Bio oil types:

Based on the characteristics and the releases on hand and issued by the suppliers of the hydraulic system components integrated in the shredding unit, it is recommended to use "HEE" hydraulic liquid types only (synthetic ester). Oils of this type comply with the standards according to DIN 51524 T2 or T3.

Producer / Type name

Aral	EHT 46 Vitam
Agip	Agip Arnica S 46
Avia	Avia Synthofluid 46
BP	Biohyd 46 SE
DEA	Econa E 46
ELF	Hydrelf Bio 46
ESSO	EGL 45947
Fuchs	Plantosyn 3268 E 00
Oest	Bio Synth. HYD 46
PANOLIN	HLP Synth. 46
SHELL	Naturelle HF-E 46
TOTAL	Equivis Bio 46
WENZEL + WEIDMANN	Ukabiol HE 46
WESTFALEN AG	Bio Forbex E 46
MOTOREX	DEKOSYNT HEES 46

8.7.1 Oil filling amounts for the gears

Infeed roller	1,5 l	Megol Hypoid-Getriebeöl GL5 SAE 85W-140
Endless floor	3.5 l	Mequin Getriebeöl CLP 320
Wheel drive	3.5 l	Mequin Getriebeöl CLP 320
Discharge conveyor	0.75 l	Mequin Getriebeöl CLP 320
Magnetic separator	0,5 l	Mequin Getriebeöl CLP 320

Gear oils: It should be used oils with viscosity 320 mm²/s at 40 °C only.

8.8 Grease types to be applied

The roller bearing grease types should be used basically, which the application of temperature ranges are from - 20 °C up to + 135 °C only.

The NLGI no. for penetration is: "2"(no liquid grease).

Do not use the liquid grease for central lubrication system.

Producer type

Autol Top 2000
Meguin Langzeitfett C2LP

8.9 Refill coolant

CAUTION



Cooler cap



Risk of burns from hot surface or liquid

- When opening the hot cooling system can cause hot steam escape.
- Always wear protective clothing and gloves when working near hot components
- Prior to working to ensure that all components have cooled to ambient temperature.
- Solve the radiator cap and drain off excess pressure..
- Refill coolant up to the top of the surge tank.
- Close radiator cap securely.

Producer	Manufacturer's designation	Viscosity in mm ² /s at 20 °C
ARAL	Antifreeze Extra	20-30
Filling amount		82 l

8.10 AdBlue

AdBlue is a high purity, synthetically manufactured 32.5% carbamide-water solution, as clear as water.

The high degree of purity and the consistent quality are guaranteed through the use of AdBlue in accordance with DIN 70070 only.

If AdBlue cooled below $-11\text{ }^{\circ}\text{C}$, it freezes.

AdBlue is stored at the original sealed containers 12 months under conditions listed below:

- Storage temperature $> -10\text{ }^{\circ}\text{C}$ respectively $< 25\text{ }^{\circ}\text{C}$;
- Protection from direct sunlight;
- Closed containers.

8.11 Proof of service routines

Date	Mach. hours	Service routine	Signature

8.12 Service addresses

J. Willibald GmbH
Maschinenfabrik
Bahnhofstraße 6
D- 88639 Wald - Sentenhart
Tel.: +49 (0) 7578 / 1890
Fax: +49 (0) 7578 / 189150
E-Mail: info@willibald-gmbh.de
www.willibald-gmbh.de

Service & Instandsetzungszentrum
Im Wolfgraben 5
D-36414 Unterbreizbach
Tel: +49 (0) 3 69 62 / 5 14 10
Fax: +49 (0) 3 69 62 / 5 14 18
E-Mail: info.ubba@willibald-gmbh.de

9.0 REPAIR

WARNING



Danger of injury due to improper repair

Improper repair can caused serious personal injury and property damage.

- Perform all maintenance work when the machine is stopped only.
- The main battery switch must be turned "OFF".
- No persons must stay on the endless floor conveyor or within the discharge area of the EP 5500 Shark!

NOTICE



Property damage caused by incorrect repair

In case of inobservance of the above items we deny assuming any claims for guarantee services and refuse to assume any liabilities in the event of personal injury and/or damage to property.

- Make sure all working cycles are strictly complied with in the prescribed order. Unauthorized manipulations of devices prohibited.
- No other than as the fuels and process materials listed herein must be used.
- Apply original spare parts only, do not use any parts other than those listed in the spare parts list.
- Work on the W-Tronic can be performed by a qualified electrician only.
- All maintenance works beyond those described in Chapters 7.7 and 8.0 must be cleared and discussed with the competent service agency first (Chapter 8.10 Service addresses).

10.0 PUTTING THE MACHINE OUT OF ACTION

The decommissioning and recommissioning of the EP 5500 Shark may be performed by trained personnel only.

WARNING



Danger of injury due to improper works

Improper works can cause serious personal injury and property damage.

- Make sure that the motor can not be started by unauthorized persons!
- The main battery switch must be turned "OFF".
- All bearings must be greased after washing the machine.
- Radiator (antifreeze control).
- See the motor operation manual.

11.0 CLEANING AND CARING

Regular care helps maintain the value of the machine. Clean the machine on a designated wash area only. Dispose of empty containers and used cleaning materials environmentally friendly manner.

11.1 Indoor cleaning

11.1.1 Motor compartment

Highly flammable materials - diesel fuel, oils and fats



WARNING

Fire hazard due to highly flammable materials!

Dirt accumulations in the motor compartment can cause a fire hazard and severe to fatal injuries.

Pieces of wood and wood dust are inflammable!

Fuel and hydraulic fluid are inflammable!

- Cleaning is permitted with the switched off motor only.
- Do not use the flammable cleaning agents.
- Clean the motor compartment with compressed air only.



NOTICE

By cleaning with compressed air increased amounts of dust is produced and the eyes are at risk.

Use the safety goggles to protect the eyes from flying small parts.

11.2 Outdoor cleaning



NOTICE

Danger of property damage due to incorrect handling with high pressure cleaners

Move the water jet during the cleaning, when cleaning with high pressure cleaner. To avoid damage, do not focus the water jet directly onto electrical components and electrical connectors.

12.0 DISPOSAL



CAUTION

Environmental hazard by incorrect handling

At an incorrect handling of environmentally hazardous substances, especially at a incorrect disposal, significant damage can occur to the environment.

- Observe always the below prescribed information.
- When accidentally get environmentally hazardous substances reach into the environment, take immediate and appropriate action. When in doubt, you must inform the responsible local authority of the loss.

The following environmentally hazardous substances are used:

Lubricants

Lubricants such as greases and oils contain toxic and environmentally hazardous substances. They must not be released into the environment. Disposal must be made by a waste disposal contractor.

Diesel fuel

Diesel fuel contains toxic and environmentally hazardous substances. They must not be released into the environment. Disposal must be made by a waste disposal contractor.

Coolant

Coolant contains toxic and environmentally hazardous substances. They must not be released into the environment. Disposal must be made by a waste disposal contractor.

AdBlue

AdBlue can be exploited by microbes and is therefore very easily degradable. This means that AdBlue presents only very minimal risk to the environment. Due to its degradability, small quantities of AdBlue can be emptied into the sewerage system when diluted with a copious quantity of water.

Large quantities of AdBlue must not enter the environment. The disposal must be carried out by an appropriate qualified disposal company.

Hydraulic oil

Hydraulic oils contain toxic and environmentally hazardous substances. Hydraulic oils must not enter drains. Avoid the intrusion into surface and groundwater as well as ground. Make sure that used oils are collected!

When leakage of absorbent material, collect this and dispose at suitable refuse site. Do not use water.

Old parts and wear parts

Old parts, as well as wear parts are subject to the mandatory inclusion in the current value of waste disposal.

13.0 Instructions for ordering of spare parts

Use the exclusive original WILLIBALD - spare parts only.

Our approved original spare parts are checked by us and thus have the suitable conditions for the use of the machine only.

For these parts, the reliability and safety has been established. For other products, we cannot do this, despite ongoing market monitoring to judge, and cannot vouch for it.

WARNING



Danger of injury by improper replacement parts

Incorrect or faulty spare parts, in particular wear parts can cause damage, malfunction or failure and impair safety.

- Use Willibald-original spare and wear parts only.

NOTICE

Orders for spare parts must be provided to and placed with the competent dealer and must contain the following particulars:

1. Machine type and machine no.
2. Part number and description of the required individual part.
3. Quantity of the desired spare parts
4. Indication of shipment address and postal code.
5. Desired way of shipment

The vehicle identification plate is attached to draw bar, right in the direction of travel of the machine.



Information on hydraulic components:

In case hydraulic components of the machine must be repaired we recommend and advise to replace complete components only.







The illustrations shown in the spare part list will not always correspond exactly to the original spare parts, as parts may have changed due to technical advancement after completion of the list.







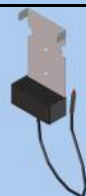

When ordering parts, the part number of which cannot be determined safely, a sample piece must be provided to WILLIBALD to avoid delivery of wrong parts.

If no demand to return said samples is made, these will be scraped.

Timely repair of the machine saves time and money!

14.0 Inventory list

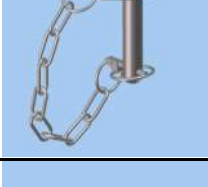
N	Designation	Picture	Willibald-No.	Quantity
1	Fire extinguisher		660-81-012	1
2	Protective film for fire extinguishers		660-81-013	1
3	Wheel wedges		053-01-001	2
4	Ladder		665-80-001	1
5	Radio remote control		911-90-011	1
6	Charging holder radio		911-90-009	1
7	Securing rod, coupling securing		665-80-007	1
8	Bolt, coupling securing		660-30-010	2

N	Designation	Picture	Willibald-No.	Quantity
9	Striking weight, flail shaft extractor		423-80-018	1
10	Auxiliary shaft, Hydraulic flail shaft extractor		660-81-027	1
11	Screw, Hydraulic flail shaft extractor		660-80-011	1
12	U-Profile, Hydraulic flail shaft extractor		665-80-006	3
13	Lever for the hand pump		665-22-501	1
14	Bolt, infeed roller securing		665-40-100	1
15	Support rod, discharge conveyor securing		665-50-398	2
16	Bolt, discharge conveyor securing		660-30-010	4
17	Bolt, discharge conveyor securing		665-50-294	2

15.0 Annex to chapter 1.3 Undertakings to be given by the personnel

Date	Forename	Name	Read confirmation of operation manual	Signature



16.0 General terms and conditions J. Willibald GmbH Maschinenfabrik, 88639 Wald-Sentenhart

- The invoice amount becomes due on the day after the invoice date; our invoices are due for payment within 8 days, of the invoice date, or according to the individual terms of payment mentioned on the invoice in question.
- If payment of an invoice becomes overdue, we will charge interest at 8% (per year) above the bank rate of the German Central Bank from the due date. Payment is considered to be late after the 30th day after the invoice date and there will be no special reminder.
- If part payments have been agreed, the total remaining sum will become due for payment immediately - without taking into consideration the due date of any bills of exchange - if the purchaser, who is a non-trader, will be totally or partly in arrears with a minimum of two back-to-back instalments and if the amount which is in arrears is minimum 1/10 of the purchase price.
- If the purchaser, who is a trader, will be 14 days in arrears with one instalment, or if he stops payment, or if composition or bankruptcy proceedings are applied to his assets.
- Payment instructions, cheques and bills of exchange will be accepted for payment but collection and discount charges will in this case always be applied.
- The purchaser may only offset against our claims if he has valid title or if his counter-claim against us is undisputed. Any right of retention for the purchaser, who is trader, is excluded and a claim can moreover only be lodged in so far as the claim is based on the contract of sale in question.
- If the purchaser is in arrears with payments, where part payments have been agreed with arrears of two back-to-back instalments, we can without prejudice assert our rights under Section II and give written notice of a period of grace of 14 days with the declaration that after the expiry of this period we can decline the completion of the contract by the purchaser. If the period of grace expires without a successful outcome, we are entitled to give written notice that we are withdrawing from the sales contract or to claim for compensation due to non-fulfilment.

II. Retention of title

- Until the settlement of bills outstanding from the contract, the object of the contract is our property. The retention of title also applies to all bills outstanding, which we have against the purchaser in connection with the object of the contract, for example because of repairs or spare parts deliveries as well as other services, which have been purchased subsequently.
On request from the purchaser we are bound to abandon the retention of title if the purchaser has paid all bills outstanding in connection with the object of the contract and if for the remaining bills outstanding in the current business relationship otherwise adequate collateral exists.
As long as the purchaser is meets his obligations out of the retention of title and is not in default of payment, he is authorised during the period of the retention of title to own and use the object of the contract. If the purchaser is in default of payment or if he does not meet his obligations out of the retention of title, we can demand the return of the object of the contract (even in part) from the purchaser and after written notice with a appropriate period, dispose of the object of the contract at the best possible price through private sale, making a charge for the disposal against the purchase price.
All costs of taking back and disposal of the object of the contract shall be borne by the purchaser. This shall, if there is no evidence, be 10% of the revenue from the disposal, including purchase tax. If we can provide evidence of higher costs, or if the purchaser can demonstrate lower costs, then they must be set higher or lower. The proceeds will be credited to the purchaser, after deduction of costs and other receivables incurred by us out of the contract of sale.
- For the period of retention of title, the purchaser undertakes to use the object of the contract carefully, to carry out services as scheduled and to take prompt action when repair work is necessary. As far as our ownership through a connection with a different product expires, it is agreed, that the customer's (co-) ownership of the same item will pass to us as a proportional value of the invoice amount. Our prior consent is required for pledges or transfers by way of security to a third party. The receivables accrued to the purchaser out of the resale or out of any other cause in law concerning the reserved goods are to be surrendered to us in full as a precaution. This must be disclosed to the third-purchaser.

III. Delivery and default in delivery

- Delivery dates or delivery periods, which may be agreed as binding or non-binding, must be submitted in writing. Delivery periods start with the signing of the contract. In the event of subsequent alterations to the contract, a new delivery date or period must be agreed at the same time.
- In case of non-binding delivery periods, the purchaser is may make a request in writing that we should deliver within an appropriate period. Once this period expires, we are in default. Only if there is a charge of intent or gross negligence against us, may the purchaser claim compensation for the delay in addition to delivery.
In the event of default the purchaser may give us a fair period of grace, in written form, notifying us that he will, after expiry of the period of grace, decline acceptance of the object of the contract. After expiry of the period of grace without a successful outcome the purchaser may withdraw from the contract in writing or claim compensation for non-fulfilment. In the event of late delivery due to slight negligence, compensation for the purchaser is restricted to a maximum of 10% of the purchase price. If the purchaser is a legal entity in public law, a separate estate under public law or a trader, for whom the contract is part of the operation of his business, he is only entitled to make a claim if there is intent or gross negligence on our part. In the cases described in this paragraph, any claim for delivery is excluded.
If when we find ourselves in areas it is impossible to make a delivery, we would then notwithstanding be liable under the terms of Paragraphs 1 and 2, unless the damage would also have occurred in the event of a timely delivery.
- If we overrun a binding delivery time/period we are already in default. In this case, too the rules of default stipulated in Item 2 above, shall apply accordingly.
- After notification of readiness to make delivery has been received, the purchaser is bound to accept the object of the contract at the latest within 14 days. Within this period he has the right, to inspect the object of the contract at the agreed place of acceptance.
If the object of the contract shows serious defects, which must be reported in the above mentioned 14-day period, that cannot be completely put right within a further 14 days, then, the purchaser may refuse to accept. If the purchaser does not observe the contractual acceptance period we can set a period of grace of a further 14 days, with the mention that we will decline any acceptance after expiry of this period. We are entitled, after unsuccessful expiry of the period of grace, to withdraw from the contract in writing or to claim compensation due to non-fulfilment. In the event of a final refusal from the purchaser, or if it is manifest that in case of a period of grace he still would not be able to pay the purchase price, a notification of readiness to make delivery and the setting of a period of grace, are not required.
- In the event of a delay in acceptance of delivery we claim compensation of 15% of the purchase price. If the purchaser can provide evidence for a lower claim or we can provide evidence for a higher claim, the amount of compensation must be set higher or lower.
- In the event of a delay in acceptance we are entitled to dispose of the object of the contract as we wish and within an appropriate period deliver an equivalent object of the contract to fulfil the terms of the contract.
- Force majors, rebellion, strike, lockout and extensive breakdown through no-one's fault shall cause delivery dates and delivery periods to be changed by the duration of the interruptions brought about through these circumstances.

IV. Changes to the object of the contract

We reserve the right to make changes during the delivery period to the design or shape, and to vary colours as well as to make changes to the scope of delivery provided the object of the contract is not changed extensively and the changes are acceptable to the customer. The figures and the specifications in catalogues and brochures are the reference without obligation. Details in valid descriptions on conclusion of a contract are subject matter of the contract; they are to be considered as

approximate and do not describe guaranteed qualities. They serve as standard for identification of the correctness of the object of the contract.

V. Liability

Our liability, regardless of on which legal ground is restricted to cases of culpable cause, also by our legal agent or assistant. In cases of intent or gross negligence we are liable without restriction to the purchaser according to the stipulations of Product Liability Law.
In the event of slight negligence our liability is subsidiary to any social security benefits, private accident insurance or private property insurance. If these insurance policies do not completely cover our liability then we are also liable in cases of slight negligence, but this is limited to a maximum of 10 % of the contract price. Depreciation of the object of the contract, loss of use and loss of profit will not be replaced in the context of liability for slight negligence. The same applies for damages caused by rectification of defects.
The purchaser's rights of the purchaser are unaffected by this.
The purchaser must notify us in writing of damages and losses for which we are answerable and create the opportunities for us or a third party specified by us to deal with them accordingly.
The liability of our legal agents, assistants and employees towards the purchaser are limited to cases of intent and gross negligence.

VI. Place of performance and delivery

Delivery is always made at the risk of, and in the case of ex-works deliveries also on the account of, the ordered or recipient. Unless there is an arrangement to the contrary, Wald-Sentenhart is the place of performance.

VII. Warranty

We guarantee that the current state of technology of the appropriate type for the object of the contract will be free of faults for 6 months in the case of used machines, 12 months for new machines from the time of delivery, assuming one-shift operation.
The warranty calls for compliance with the agreed terms of payment. It includes the replacement free of charge ex-works of all parts that are found to be unserviceable during the warranty period when used properly in on e-shift operation due to material defect, design fault or defective execution. Natural abrasion is excluded from this warranty.
For processing of the claims by the purchaser for the rectification of defects, it is agreed that claims will be asserted at our company or at the local Willibald-agency through which the object of the contract was purchased. The company against whom the claim is made must be notified in writing of the defect immediately it is discovered or the company must be allowed to record it for itself.
If additional specified servicing becomes necessary because of the rectification of defects, the costs will come by us, including the cost of any materials and lubricants required.
The parts installed during the rectification of defects are guaranteed until the expiry of the warranty period for the object of the contract on the basis of the contract of sale. Any extended guarantee beyond that is excluded.
In the event that the object of the contract is not serviceable as a result of a defect covered by the warranty, the purchaser must contact our nearest authorised workshop. This company will decide if the necessary work will be carried out on the spot or in a workshop. In the latter case the purchaser will not be charged towing costs.
If a defect cannot be rectified or if the purchaser finds further attempts to rectify the defect are unacceptable, he may request conversion (cancellation of the sale contract) or contraction (reduction of payment) instead of the defect rectification. He does not have the right to request a replacement; however we can specify that we will deliver by way of compensation a service of equal performance in place of the object of the contract originally delivered.
Change of ownership of the object of the contract does not affect the obligations under the warranty.

Incorrect handling, failure to report damage, the hindrance of opportunities to rectify defects, overuse of the object of the contract, repairs and maintenance carried out by unauthorised companies, installation of parts from other companies, which we have not approved for use, unauthorised changes to the object of the contract and offence against duty of care are excluded from our warranty.

In the absence of guaranteed qualities, any claim for compensation because of non-fulfilment remains unaffected.

Existing warranty claims lapse on expiry of the warranty obligations according to No. 1. For claims asserted within the warranty period, but where the fault has still not been rectified, the warranty will apply until rectification of the same. The limitation period is put back to this extent for this fault.

There can be no further warranty claims, in particular for compensation for consequential damage caused by defects and further claims arising from a definite default in performance of contract, unless there is liability insurance.

VIII. Written form

All contracts are not deemed to have been concluded until they have been confirmed by us in writing. This also applies to subsidiary agreements and confirmations as well to subsequent contract changes. Sales conditions that conflict with our terms of payment and delivery are only valid if we have expressly stated in writing that we are in agreement with these; otherwise we herewith agree that our general terms and conditions shall have priority.

The transfer of rights and duties arising out of the contract require our written agreement.

IX. Court of Jurisdiction

The court of jurisdiction shall the District Court in Constance/Local Court in Überlingen. This court of jurisdiction applies for all current and future claims arising out of the business relationship with full traders, including bills of exchange and cheque receivables.

The same court of jurisdiction applies if the purchaser does not have a general court of jurisdiction in his own country, or if after conclusion of the contract he changes his residence or usual domicile in his own country or if his residence or usual domicile is unknown at the time when the claim is lodged.

X. Other agreement/ruling in individual cases

The general business and delivery terms of our current contracting partners shall not have any effect in reciprocal relationships, unless this was confirmed by us individually in each case when the contract was concluded.