

Operating Instruction

Mobile Processing Shredder

WILLIBALD EP 5500 Shark 5

with MAN engine EU stage V

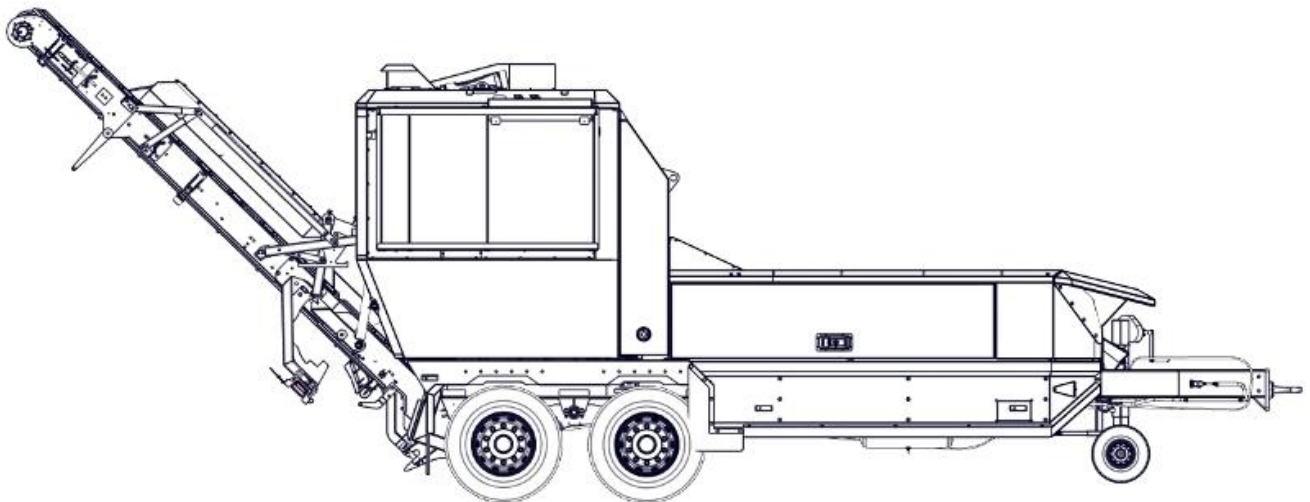

TRANSLATION OF THE ORIGINAL INSTRUCTIONS

Table of contents

| | | Page |
|------------|---|-----------|
| 1.0 | GENERAL | 6 |
| 1.1 | Foreword | 6 |
| 1.2 | Operator's obligation | 6 |
| 1.3 | Undertakings to be given by the personnel | 6 |
| 1.4 | Explanation of symbols | 7 |
| 1.5 | Guarantee and liability | 8 |
| 1.5.1 | Warranty and fair trading requests | 8 |
| 1.5.2 | Acknowledgement and compensation | 9 |
| 1.5.3 | Special agreements | 9 |
| 1.6 | Copyright | 10 |
| 2.0 | DESCRIPTION OF THE PRODUCT | 11 |
| 2.1 | Tasks of the machine | 11 |
| 2.2 | Intended use | 12 |
| 2.3 | Working place | 13 |
| 2.4 | Technical characteristics | 15 |
| 2.5 | Equipment | 16 |
| 3.0 | SAFETY PRESCRIPTIONS | 20 |
| 3.1 | Personnel requirements | 20 |
| 3.1.1 | Skills | 20 |
| 3.1.2 | Training of personnel | 20 |
| 3.1.3 | Personal protective equipment | 21 |
| 3.1.4 | Informal safety measures | 22 |
| 3.1.4.1 | Symbols and markings on the machine | 22 |
| 3.1.4.2 | Overview labels and warning signs | 23 |
| 3.1.4.3 | Illustration labels and warning signs | 24 |
| 3.1.4.4 | Position labels and warning signs | 27 |
| 3.2 | SAFETY INFORMATION and potential dangers in use of the machine | 31 |
| 3.2.1 | Protective devices | 31 |
| 3.2.2 | Safety measures in normal operation | 31 |
| 3.2.3 | Machine control | 31 |
| 3.2.4 | EMERGENCY STOP device | 32 |
| 3.2.5 | Dangers caused by electric energy | 33 |
| 3.2.6 | Dangers caused by hydraulic energy | 33 |
| 3.2.7 | Passing out of noxious steams and gases | 34 |
| 3.2.8 | Noise level produced by the machine | 34 |
| 3.2.9 | Service and maintenance, elimination of faults | 34 |
| 3.2.10 | Constructional modification of machine | 35 |
| 3.2.11 | Cleaning of machine and disposal | 36 |
| 3.3 | WARNINGS and special dangers in use of the machine | 37 |
| 3.3.1 | Fire hazard in motor compartment | 37 |
| 3.3.2 | Fire hazard by replenishing with fuel | 37 |
| 3.3.3 | Danger resulting coolants -antifreeze and anti-corrosion agent | 38 |

| | | |
|------------|---|-----------|
| 3.3.4 | Damage resulting from crystallized reducing agent AdBlue® | 38 |
| 3.3.5 | Dangers due to hot surface or liquid | 39 |
| 3.3.6 | Dangers due wiring harnesses and plug connections | 39 |
| 3.3.7 | Danger due to strong magnetic fields | 40 |
| 3.3.8 | Danger by filling the machine | 41 |
| 3.3.9 | Danger by hydraulic feed-hopper | 42 |
| 3.3.10 | Danger by discharge conveyor | 42 |
| 3.3.11 | Danger due rotating rotor | 43 |
| 3.3.12 | Danger due rotating idler roll and power belt | 43 |
| 4.0 | FUNCTIONING | 44 |
| 4.1 | Processing task | 44 |
| 4.2 | Construction | 44 |
| 4.3 | Functional principle | 44 |
| 4.4 | Safety equipment | 47 |
| 4.4.1 | Emergency off button | 47 |
| 4.4.2 | EMERGENCY STOP button on the radio | 47 |
| 4.4.3 | Main battery switch | 47 |
| 4.4.4 | Siren | 48 |
| 4.5 | Safety equipment for maintenance and repair work | 49 |
| 4.5.1 | Motor hood securing | 50 |
| 4.5.2 | Coupling securing | 52 |
| 4.5.3 | Infeed roller securing | 51 |
| 4.5.4 | Discharge conveyor securing | 52 |
| 5.0 | OPERATION MANUAL T-Wision 1.5 | 53 |
| | (See separate operating instructions in the machines documentation, point 2.) | |
| 6.0 | COMMISSIONING / START-UP | 54 |
| 6.1 | Introduction | 57 |
| 6.2 | Transport of EP 5500 Shark | 60 |
| 6.3 | Start-up of the machine | 60 |
| 6.3.1 | Safety information | 60 |
| 6.3.2 | Setting up the EP 5500 Shark | 60 |
| 6.3.3 | Motor hood opening | 61 |
| 6.3.4 | Checking the hydraulic oil level | 62 |
| 6.3.5 | Checking the motor oil level | 62 |
| 6.3.6 | Checking the diesel fuel level | 63 |
| 6.3.7 | Checking the coolant level | 63 |
| 6.3.8 | Checking the AdBlue® - System | 64 |
| 6.3.9 | Motor hood closing | 64 |
| 7.0 | OPERATION | 65 |
| 7.1 | Starting, short description | 65 |
| 7.2 | Adjustments | 67 |
| 7.3 | Turning out, short description | 68 |
| 7.4 | Emergency-Off function | 68 |
| 7.4.1 | Press back the idler roll | 69 |

| | | |
|-------------|---|------------|
| 7.5 | Transfer of machine | 71 |
| 7.5.1 | Transfer machine without wheel drive | 71 |
| 7.5.2 | Transfer machine with wheel drive | 72 |
| 7.6 | Turning of the EP 5500 Shark, start of a new compost windrow forming procedure | 73 |
| 7.7 | Replacement of wear parts | 74 |
| 7.7.1 | Taking the discharge conveyor in maintenance position | 75 |
| 7.7.2 | Replacement of flails | 78 |
| 7.7.3 | Replacement the rakes of crushing basket | 87 |
| 7.7.4 | Replacement of the shredding flap | 88 |
| 7.7.5 | Replacement of power belt | 89 |
| 7.7.6 | Adjusting the angle sensor | 90 |
| 7.8 | Fault indication at the control | 92 |
| 7.9 | Fault finding table | 94 |
| 8.0 | MAINTENANCE | 97 |
| 8.1 | Lubrication plan and other maintenance works | 100 |
| 8.2 | Lubricant table EP 5500 Shark | 104 |
| 8.3 | Replacement of the trailer coupling ring | 105 |
| 8.4 | Replacement of brake linings | 105 |
| 8.5 | Changing of wheels | 105 |
| 8.6 | Changing of hydraulic oil | 105 |
| 8.7 | Recommended hydraulic oil types | 106 |
| 8.7.1 | Oil filling amounts for the gear | 107 |
| 8.8 | Grease types to be applied | 107 |
| 8.9. | Engine oil change | 108 |
| 8.10 | Refill coolant | 108 |
| 8.11 | Proper function of the emission reduction system | 109 |
| 8.11.1 | AdBlue® / DEF quality | 109 |
| 8.11.2 | Refill AdBlue® / DEF tank | 109 |
| 8.11.3 | EU Stage V - Emission Requirements | 110 |
| 8.12 | Proof of service routines | 111 |
| 8.13 | Service addresses | 112 |
| 9.0 | REPAIR | 113 |
| 10.0 | PUTTING THE MACHINE OUT OF ACTION | 113 |
| 11.0 | CLEANING AND CARING | 114 |
| 11.1 | Indoor cleaning | 114 |
| 11.1.1 | Motor compartment | 114 |
| 11.2 | Outdoor cleaning | 114 |
| 12.0 | DISPOSAL | 115 |
| 13.0 | INSTRUCTIONS FOR ORDERING OF SPARE PARTS | 116 |
| 14.0 | Inventory list | 117 |
| 15.0 | Annex: Undertakings to be given by the personnel | 119 |
| 16.0 | General terms and conditions | 120 |

PRODUCT IDENTIFICATION

Machine type : EP 5500 Shark
Year of construction :
Machine-No. :
Chassis-No. :
Motor type :
Motor-No. :

Manufacturer address :

| |
|-------------------------|
| J. Willibald GmbH |
| Bahnhofstrasse 6 |
| D-88639 Wald-Sentenhart |
| +49 (0) 7578 / 189 0 |
| +49 (0) 7578 / 189 170 |
| info@willibald-gmbh.de |

Phone-number :

Fax-number :

E-mail-address :

Dealers address :

| |
|--|
| |
| |
| |
| |

Clients Service Address :

| |
|--|
| |
| |
| |
| |

The vehicle identification plate is attached to draw bar, right in the direction of travel of the machine.



1.0 GENERAL

1.1 Foreword

Thoroughly read and observe all information, warnings and safety notes contained in this operation manual *before* commissioning of the machine.

- Knowledge of all basic safety information and warnings contained in this operation manual as well as of the safety prescriptions is the basic prerequisite for the appropriate handling and trouble free operating of this machine.
- This operation manual contains all important information necessary in order to operate the machine in an appropriate and safe manner.
- This operation manual, especially the safety information contained herein, must be observed by all persons working on or with the machine.
- In addition, all rules and prescriptions valid and in force at the place of operation must thoroughly be observed and complied with by all means.

1.2 Operator's obligations

The operator is obliged and undertakes to only allow persons to work on or with the machine who

- are no younger than 18 years;
- are familiar with all basic rules and prescriptions operative and in force in regard to safety at work and to accident prevention and who have been introduced into the handling of this machine and have been assigned to their duties;
- Have read and fully understood the chapter contained in this manual referring to safety information and warnings and who have confirmed to have done so by their signature.
- The operator undertakes to control his personnel in regard to safety conscious working.

1.3 Undertakings to be given by the personnel

Before starting to work, all persons charged to work on or with this machine commit themselves

- to observe the basic rules and prescriptions valid and in force in regard to safety at work and prevention of accidents;
- to read the chapter on safety information and warnings contained in this operation manual and to confirm to have fully understood its contents and to have done so by their own signature. See you table on the page 119.

1.4 Explanation of symbols

In this operation manual the following safety symbols, warnings and descriptions are used to mark possible dangers:



DANGER

This symbol indicates an imminently dangerous situation which will result in death or serious injury if the safety measures are not followed. Inobservance of this guidance entails serious consequences to the health of persons and can cause severe bodily or fatal injuries.



WARNING

This symbol indicates a potentially dangerous situation that can result in death or serious injury if the safety measures are not followed. Inobservance of this guidance can entail serious consequences to the health of persons, be causal for severe bodily injuries or be fatal.



CAUTION

This symbol indicates a potentially dangerous situation that can lead to minor injuries when security measures are not followed. Inobservance of this guidance may result in light injuries or be causal for damage to property.

NOTICE

This symbol indicates a potential for property damage which may arise when security measures are not followed.

This symbol indicates important information given in regard to the appropriate handling of the machine.

Inobservance of this information may result in disturbance or malfunction of the machine or may cause interferences with the environment.



This symbol indicates important information, application tips as well as other useful information.

The above symbols are to help you to utilize all functions of your machine in the best possible way.

1.5 Guarantee and liability

Basically, our "General Standard Sales and Delivery Conditions" are operative, of which the operator, at its latest, will receive a copy at the date of the conclusion of contract. See annex on the page 120. The producer does not assume liability for any personal injury and damage to property whatsoever if any such damage is attributable to one or several of the following causes:

- Machine not applied in compliance with the intended use;
- Inexpert mounting, commissioning, start-up, handling and servicing of the machine;
- Operation of machine with defective, inoperative or not properly mounted safety devices and protective gear;
- Non-observance of information and warnings contained in this operation manual in regard to transport, mounting, commissioning, operation and set-up of the machine;
- Use of parts that aren't original WILLIBALD spare parts;
- Unauthorized constructional modification of the machine;
- Unauthorized modification of the EP 5500 Shark (e.g. gear ratios, output and r.p.m.), hydraulic pressure;
- Insufficient control of machine parts subject to wear;
- Repairs performed in an inexpert manner;
- Disasters caused by the influence of foreign bodies or substances or by force majors.

1.5.1 Warranty and fair trading requests

a) Warranty and fair trading requests require written form. Here our warranty and fair trading request form must be used.

b) Parts, units or sets changed under the guarantee coverage must - without being asked to do so - be provided to us *free of costs* for detailed examination and be sent in no later than four 4 weeks after occurrence of the damage complained about.

c) Basically, all spare parts, sets and units ordered from us will be billed to our customers, no matter if needed for any works to be performed under the granted guarantee coverage or not. A possible credit note can take place only after examination and acknowledgment of the appropriate warranty and fair trading request.

d) Transport damages do not go in principle to our loads.

e) Warranty or fair trading requests is to have arrived 2 weeks, at the latest 4 weeks after damage entrance with us. Later received requests can be worked on only after previous arrangement.

1.5.2 Acknowledgement and compensation

If the customer's application for services to be rendered under the granted guarantee coverage and/or for accommodation ex gratia was acknowledged, WILLIBALD shall compensate for the following:

a) After our discretion and in the context of our business obligation appearing necessary construction units, see page 111 of maintenance proof.

b) Subject to our discretion: all expenditure of works as deemed necessary for the replacement of parts and components under said guarantee coverage.

c) Subject to our discretion: costs spent on travelling to WILLIBALD, which applied only, however, if the customer – due to important reasons – cannot be expected to visit an after-sales-workshop. The compensation from hourly rate and km are from Willibald for guarantees stated.

d) Maintenance and service routines and related expense of works do not form part of the guarantee coverage. Same also applies if the customer has failed to perform such work and routines as prescribed to the result of damages caused to the machine, which the customer tries to have retrieved by works rendered under the granted guarantee term. For cargo is normal transport compensate, only. No Express.

e) Fundamental applies:

The exclusive WILLIBALD - original spare parts must be used.

1.5.3 Special agreements

Any guarantee terms other than the terms set forth herein must be in writing.

Guarantee terms operative for WILLIBALD machines:

a) The guarantee period is 12 months or 1.000 operating hours from delivery - whichever comes first.

b) Warranty for the engine: 24 months or 1.800 operating hours from delivery - whichever comes first.

c) The guarantee for elements and technical components used in the machine other than of our own make, such as hydraulic pumps, hydraulic motors, electronically components etc. can only be assumed insofar as we ourselves can enforce claims against our suppliers under the guarantee coverage granted to us, and only to such extent as we are entitled to receive such performances.

d) The above guarantee does not include wear parts, such as flails, plug-in shaft, tool kit, V-belts, filters, bearing etc.

1.6 Copyright

The company J. WILLIBALD GmbH holds the sole copyright in present operation manual. This operation manual is for the exclusive use by the operator and his personnel.

It contains prescriptions, information and notes, which may neither partially nor completely

- be copied
- distributed or
- communicated otherwise.

Contravention to the above may entail penal measures and result in legal consequences.

J. WILLIBALD GmbH
Recyclingtechnik

2.0 DESCRIPTION OF THE PRODUCT

The Machine EP 5500 Shark is built according to the state of the art and the recognized safety rules.

2.1 Tasks of the machine

- Defibration of organic material of thicknesses of up to 30 cm for composting (gardening wastes, material from the landscape development, sawn timber, wastes from cemeteries).
- Shredding (volume reduction) of used or waste wood to thicknesses of up to 30 cm.

Illustration 2.1
EP 5500 Shark
Side view

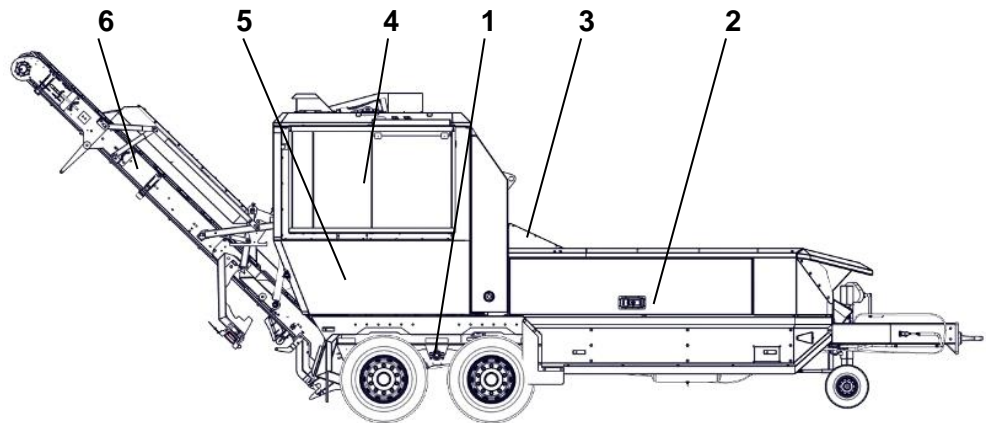

1. Chassis
2. Filling tub with leadership
3. Feed rollers
4. Engine
5. Shredding unit
6. Discharge conveyer

Inexpert use of the machine can result in serious injury to the user or third, respectively, damage to the machine or other property. The machine must be applied only:

- for its intended use;
- in perfect condition that as regards safety technique only.

Any disturbances or malfunctions that could impair safety have to be eliminated immediately.

2.2 Intended use

The mobile processing shredder is built exclusively for shredding organic material and should be used for that only.

Any use beyond this will be considered as not in accordance with the intended use.

J. WILLIBALD GmbH does not assume any liability for damages resulting from it whatsoever.

The risk is taking upon exclusively the operator.

Intended use also means and includes observance of all information contained in this operation manual and due compliance with all inspection works and service routines as prescribed herein.

Unauthorized modifications of the machine exclude liability for any resulting property damage and personal injury.

DANGER



Not intending use danger.

Any use beyond intended use is considered as not in accordance with the intended use and / or other use of the machine, resulting in dangerous situations, and it extinguished operating permit.

The machine should be used as intended only.

The wheel drive must be used on even ground only. Any use beyond that is considered as not in accordance with the intended use. The producer cannot be held liable for damages resulting from any such improper use.

The wheel drive is no substitute the parking brake!

CAUTION



Danger of inappropriate use

Inappropriate use of the EP 5500 Shark may cause bigger damages to the machine and may also affect safety devices and protective gear to the result that the operator's personal safety can no longer be guaranteed.

In particular, the EP 5500 Shark must not be used for the following operations:

- The shredding of rubbish from construction sites and ceramic wastes;
- The shredding of metal scrap and other metal parts;
- The shredding of ceramic scrap.

2.3 Working place

Using area

The machine EP 5500 Shark can be used for the processing of bulky coarse wood (wood packaging, wood, garbage, industrial waste wood, building demolition wood) as a basis for operating biomass cogeneration plants and for the crushing of green waste for composting.

The large volumes material can be crushed on the spot.

Destination

There is the processing of large volumes of raw material savings energy in the shortest possible time.

Operator

The machine is operated by one operator who loads (fills) the machine at the same time.

The machine must be operated in compliance with the instructions by trained personnel who are at least 18 years old.

Working place / Danger zones

Right

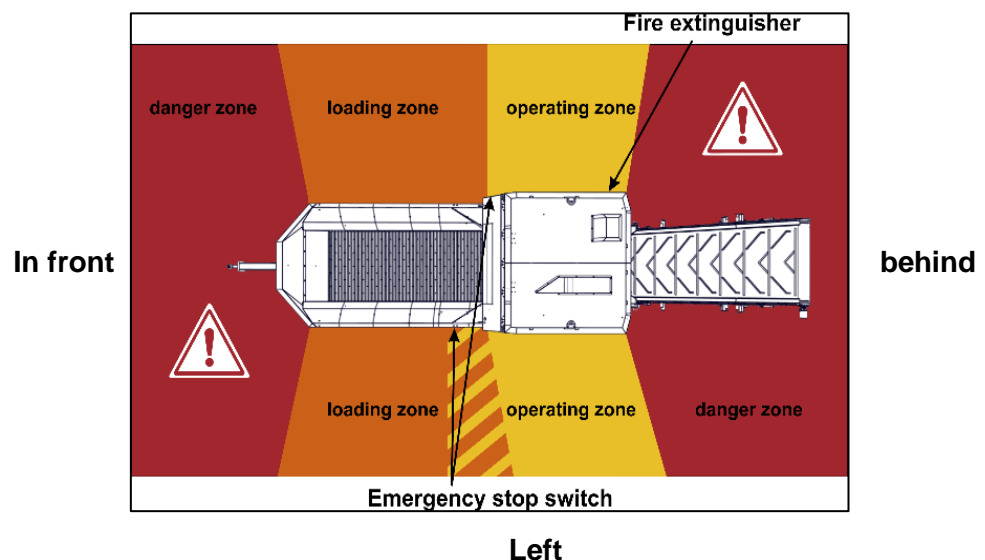

Illustration 2.2
EP 5500 Shark
Danger zones

During the machine is working, the operator must pay attention to the zones marked in illustration 2.2.

In addition, the operator must ensure that there are no other people in the danger area.

Special note: The operating zone "left" in the direction of travel overlaps with the filling zone!

Method

The operation of the EP 5500 Shark is carried out by control cabinet or remote control. Optical function and fault of the central cabinet comply with the latest safety regulations.

All important functions can be easily operated via remote control from the user.

NOTICE

- The machine can run on even ground under constant observation only. Secure a large enough environment so that no hazard may arise from defective or faulty radio communication system!
- In an emergency, use the emergency stop switch on the machine!
- The control cabinet is to hold necessarily closed on account of the ingress of moisture and dust.
- The surface of the keyboard is sensitive to sharp objects. The buttons must be pressed with the finger with gentle pressure only.
- The remote control is so stored, that unauthorized or others use is excluded. This is particularly true during operating the machine.

2.4 Technical characteristics

Illustration 2.3
 EP 5500 Shark
 Side view

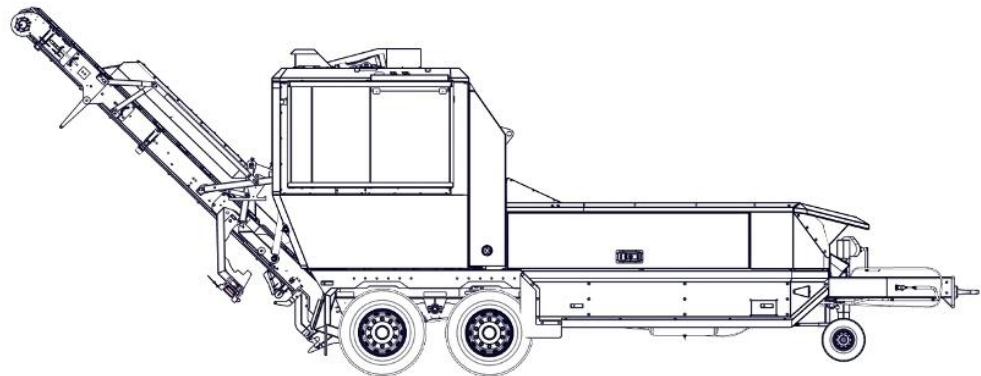

| | |
|---|---|
| Driving speed: | **max 80 km/h with Anti-locking system |
| min. trailer load at traction vehicle.: | ** > 18.000 kg |
| min. trailer support load at traction vehicle | ** > 1.000 kg |
| Throughput: | |
| - green waste | up to 220 m ³ /h |
| - wood waste | up to 130 m ³ /h |
| - pre-shredded wood waste | up to 210 m ³ /h |
| - bark | up to 230 m ³ /h |
| Feed opening | |
| - Width | 1.450 mm |
| - Height | 900 mm |
| Height of loading | 2.200 mm |
| Height of transfer | 3,5 m (optional 4,5) |
| Dimensions: | |
| Transport position (LxWxH) | 9.950x2.500x3.950 mm |
| Work position (LxWxH) | 11.750x2.500x4.500 mm |
| Weight: | **max. 19.000 kg |
| Electrical system: | 24 V |
| Battery: | 2 lead accumulators 12 V / 135 Ah |
| Number of axes: | 2 (tandem type) |
| Brake system: | 2 circuit compressed air brake |
| Engine power EP 5500 Shark | 352 kW / 480 PS 338 kW / 521 PS |
| Rotor r.p.m.: | |
| Variant V1 with 48 flails | 1.150 to 1.250 min ⁻¹ |
| Variant V2 with 40 flails | 1.150 to 1.250 min ⁻¹ |
| Variant V3 with 16 flails | 900 to 980 min ⁻¹ |
| Variant V4 with 32 flails | 900 to 980 min ⁻¹ |
| Variant V5 with 48 tools | 660 to 800 min ⁻¹ |
| Rotor diameter | 1.100 mm |
| Fuel tank: | 500 l Diesel normal operation time |
| Hydraulic tank: | 330 l hydraulic oil |
| Antifreeze: | up to -25° C, factory side |
| AdBlue® / DEF-tank | 80 l |

**** Sizes and weights vary depending on standard equipment and accessories**

2.5 Equipment

Standard version of a mobile processing shredder:

Base frame with running gear, spring born twin axle for drive speeds up to 80 km/h, pneumatic brake system, 385/65 R22.5 tire equipment, endless floor with cleaning worm, top mounted built-on motor, rotor driven via power belts, flail shaft on option either equipped with 48,40,32, 16 or 10 freely swinging flails, power connection via hydraulically operated tension roller, counter blades for optimal defibration of the material process, a hydraulically driven self-cleaning draw-in roller, a complete hydraulic system including 330 l oil tank, load depending automatic regulation of both endless floor and draw-in roller, wheel chock, lighting installation in compliance with StVZO (German Regulations Authorizing the Use of Vehicles for Road Traffic), equipped with a 4 kg fire extinguisher (ABC), lacquering: RAL 6018.

* Additional equipment:

- Rubber discharge conveyor can be folded hydraulically;
- Antiskid system;
- Radio control;
- Wheel drive;
- Central lubrication;
- Reversible fan;
- Acoustic insulation for motor;
- Hydraulic feed-hopper extension;
- Hydraulic folding tail-board increase;
- Hydraulic front wheel;
- Additional fuel tank large / small;
- Working light;
- Crawler track type chassis;
- Magnetic separator;
- Hydraulic axle extractor;
- Water spray system;
- Hydraulic discharge flap.

Designations applied at the machine

Designations, such as type plate and machine no. have been applied right side of the machine at the drawbar; CE sign is on the left side of shredding units above control cabinet.

*** Discharge conveyor**

The discharge conveyor allows forming up compost windrow heaps of up to 3,5 m height to the advantage of higher working safety in the discharge area as well as to the advantage of it is the loose stratification of the shredded materials, thus enabling make up higher heaps.

*** Anti-skid system**

The anti-skid system is prescribed with machines over 10 tons for driving speed of up to 80 km/h. However no anti-skid system is necessary for permission to 60 km/h.

*** Remote (radio) control**

The remote (radio) control enables to operate the control panel partially from a distance, so that there is no need to access the machine directly. The functions that can be remote controlled are: stop, control of the draw-in rollers, the heavy duty floor conveyor (endless floor), discharge belt and motor r.p.m. as well as the non-locking functions such as wheel drive and reshredding control etc.

*** Wheel drive (Driving forward device)**

By wheel drive of an advance EP 5500 Shark on a level and firm ground with a tractor is unnecessary. (The machine can drive automatically (radio)). This has the advantage of continuous filling.

The wheel drive is no substitute the parking brake!

*** Automatic central lubrication system**

The connected lubrication points are lubricated in preset intervals while the machine is on duty.

*** Reversible fan**

The direction of rotation of the fans of the main condenser and oil cooler will reversed by controlling for a short time automatically. This option is used to clean the grille, and also to protect the machine from overheating.

*** Acoustic insulation for motor**

The sound pressure level produced by the machine exceeds 83 dB (A). For the sound insulation of the motor compartment of the machine the inside of the hood in the engine room were provided with insulation material.

*** Hydraulic hopper extension;**

The hydraulic hopper extends filling tub of the machine and is practical for bulky raw material.

* Tail-board increase

The tail-board increase increases the loading area of filling tub.

* Hydraulic front wheel

The front wheel on the drawbar is used to keep the machine at standstill and disengaged in balance. As a standard design the front wheel can raise and lower by turning the crank manually.

The hydraulic front wheel moves over the radio remote control.

* Additional fuel tank large / small

The tank that is used in addition to the main tank of the machine, serves to increase the range or the duration of use. Additional tank large / small

The large additional tank has a capacity of approx. 360 l, the small tank approx. 195 l.

* Working light

With the work lights, which are in the middle of the hood, the loading area of the machine is illuminated.

* Crawler track type chassis

By crawler track is the weight of the vehicle to a larger area distributes and reduces the pressure on the ground. The contact area is increased significantly and captured more points of contact on uneven ground. The total off-road capability is greatly increased.

* Magnetic separator

The magnetic drum separator is a sorter pieces of metal from the processed wood material. The separation effect is that it is magnetisable substances are attracted by the magnetic roller and are then collected in the separator.

* Hydraulic axle extractor

Each machine is equipped with a mechanical axle extractor. The hydraulic shaft extractor is used for faster and easier tool changes.

* Water spray system

When dry material is shredded, the rotor generates dust-containing circulating air. This occurs outside when moving in and ejecting. The water spray system forms a wall of fog and binds the dust.

* Hydraulic discharge flap

Hydraulic ejection flap enables precise loading of the shredded material directly from the discharge conveyor into the transport vehicle.

EC-Declaration of Conformity

Within the meaning the EC Machinery Directive 2006/42 EC, Annex II A

We here confirm that the following machine

Designation of machine: **Mobile Processing Shredder**

Type designation: **EP 5500 Shark**

Machine no.:

Manufacturer: **J. Willibald GmbH, D - 88639 - Wald – Sentenhart**

due to designing and make and the type version marketed by our company meets with the basic and relevant safety and health requirements as specified and set forth in the corresponding EC Directives.

EC directives to be complied with:

- | | | |
|-------------------------------------|--|-------------|
| <input checked="" type="checkbox"/> | EC- Machinery Directive | 2006/42 EC |
| <input checked="" type="checkbox"/> | EMC Directive | 2014/30 EU |
| <input checked="" type="checkbox"/> | EC-Directive on polluting noise emissions of to use in the free one of planned device and machines | 2005/88 EC |
| <input checked="" type="checkbox"/> | EC-Directive on the brake systems of specific vehicle classes and their trailers | 98/12 EC |
| <input checked="" type="checkbox"/> | EC-Directive regarding the harmonization fh the legislative provisions enacted by the Community Member States on measures to be taken to control the emission of aggressive gasiform substances and air-pollutant particles originating from combustion engines used to power mobile equipment an machines | 2006/105 EG |

The following harmonized standards have been applied:

- | | | | | | | | |
|-------------------------------------|----------------|-------------------------------------|----------------|-------------------------------------|-----------------|-------------------------------------|--------------|
| <input checked="" type="checkbox"/> | DIN EN 12100 | <input checked="" type="checkbox"/> | DIN EN 349 | <input checked="" type="checkbox"/> | DIN EN ISO14120 | <input checked="" type="checkbox"/> | DIN EN 4413 |
| <input checked="" type="checkbox"/> | DIN EN 13849-1 | <input checked="" type="checkbox"/> | DIN EN 13849-2 | <input checked="" type="checkbox"/> | DIN EN 13857 | <input checked="" type="checkbox"/> | DIN EN 13850 |
| <input checked="" type="checkbox"/> | DIN EN 14119 | <input checked="" type="checkbox"/> | EN 60204-1 | <input checked="" type="checkbox"/> | DIN EN 620 | <input checked="" type="checkbox"/> | DIN EN 13525 |
| <input checked="" type="checkbox"/> | DIN EN 13683 | | | | | | |

This declaration of conformity becomes invalid if the machine or parts of the machines are changed or altered without our previous agreement and consent.

A complete technical documentation is available and at hand. The machine related operating instructions are available and hand:

- | | | | |
|-------------------------------------|---------------------------|-------------------------------------|---|
| <input checked="" type="checkbox"/> | in their original version | <input checked="" type="checkbox"/> | as version translated into the user`s native language |
|-------------------------------------|---------------------------|-------------------------------------|---|

Person authorized to compile the technical file:

A. Willibald

J. Willibald GmbH, Recyclingtechnik, Bahnhofstraße 6, D-88639 Wald- Sentenhart

Manufacturer:

J. Willibald GmbH, Recyclingtechnik, Bahnhofstraße 6, D-88639 Wald- Sentenhart

Place, Date, Signature

J. Willibald -Managing Director-

A. Willibald - Managing Director-

3.0 SAFETY PRESCRIPTIONS

3.1 Personnel requirements

3.1.1 Skills

In the operating manual the following skills for various activities are identified:

- **Trained staff** is a person who was in a teaching via its assigned tasks and potential hazards of improper behaviour taught.
- **Professional staff** is a person who is due to their specialized training, knowledge and experience and knowledge of the relevant provisions in a position to carry out the tasks entrusted to professional standards.
- **Electrician specialist staff** is a person who is due to their specialized training, knowledge and experience and knowledge of relevant standards and regulations in a position to carry out work on electrical systems, identify and avoid potential hazards.
- **The electrician specialist staff** is responsible for the specified application spot in which it operates, trained and familiar with the relevant standards and regulations.
- **Operating personnel** is the person who is responsible for installing, operating, adjusting, maintaining, cleaning, repairing or transporting machinery.

3.1.2 Training of personnel

WARNING



Danger for unauthorized

- Unauthorized persons do not meet the requirements described here do not know the dangers in the work area.
- The trained and qualified personnel may work on the machine only.
- The responsibilities of the staff should be clearly indicated for the installation, commissioning, operation, maintenance and repair.
- The apprentice personnel must be trained under the supervision of an experienced person on the machine.

3.1.3 Personal protective equipment

At work is the wear of personal protective equipment required to minimize health hazards.

- The required personal protective equipment must be provided by the operator.
- All safety equipment must be checked regularly.
- You must to wear always the necessary personal protective equipment by each operation.
- Comply in the work area existing labels for personal protective equipment.

Helmet



to protect against falling and flying parts.

Protective goggles



to protect the eyes from flying parts.

Hearing Protection



to protect against hearing loss by noise

This label is affixed to both sides of the machine.

Description: take during working the safety helmet, safety glasses and ear protection.



Safety Gloves



There are to protect the hands from friction, scraping, punctures or deep injuries and to protect from hot or caustic parts or fluids.

3.1.4 Informal safety measures

- This operation manual must permanently be kept and be at hand at the place of operation of the machine;
- Present operation manual and all prescriptions contained herein are supplemented by generally operative and local regulations in regard to accident prevention and to environmental protection. These too must be made available and complied with;
- All safety information and warnings applied at the machine must be kept in always legible condition.

3.1.4.1 Symbols and markings on the machine

- These symbols, information signs, pictograms, warning and mandatory signs are stickers with information about the handling of the machine. They are for your safety and must be heeded!
- Ensure that the signs are always legible. In case of damage or loss, the signs must be replaced immediately!

3.1.4.2 Overview labels and warning signs

| Pos | Designation | Quantity | Willibald-N |
|-----|---|----------|-------------|
| 1 | Attention trap-door! | 2 | 199-01-126 |
| 2 | Never walk on the loading area when the motor is on! | 2 | 199-01-127 |
| 3 | Attention rotating parts! | 2 | 199-01-128 |
| 4 | Never open or remove safety devices with running motor. | 1 | 199-01-129 |
| 5 | Never reach into the crushing danger area as long as parts may move. | 2 | 199-01-704 |
| 6 | Obstacle above, danger place! | 2 | 199-01-705 |
| 7 | Warning of fire hazard! Read before commissioning instructions and safety information! | 1 | 199-01-275 |
| 8 | Warning of fire! Fire, naked flame and smoking are banned! | 1 | 199-01-276 |
| 9 | Attention corrosive material AdBlue®! | 1 | 199-01-698 |
| 10 | Attention Magnet! | 2 | 199-01-130 |
| 11 | Take during working the safety helmet, safety glasses and ear protection! | 2 | 199-01-139 |
| 12 | Fire extinguisher | 1 | 199-00-019 |
| 13 | Prior to any repair, maintenance or cleaning work make sure the engine and main battery switch are in "OFF" position! | 1 | 199-01-132 |
| 14 | CE-sign | 1 | 665-81-017 |
| 15 | Machines Quick Guide for Willibald - Shredder | 1 | 199-01-1218 |
| 16 | Notice sign: "gearbox, oil quantity, quality" | 1 | 199-01-369 |
| 17 | Notice sign: "Attention! Grease nipple" | 1 | 199-01-306 |
| 18 | Notice sign: "Ladder" | 5 | 199-01-161 |
| 19 | Notice sign: "Diesel fuel only" | 2 | 199-01-159 |
| 20 | Notice sign: "Tire pressure" | 4 | 199-01-136 |
| 21 | Notice sign: "Hand pump lever " | 1 | 199-01-167 |
| 22 | Notice sign: "Retighten bolts" | 1 | 199-01-149 |
| 23 | Notice sign: " Attach the safety chain" | 2 | 199-01-1227 |
| 24 | Notice sign: „Attention! Hood protection!" | 1 | 199-01-156 |
| 25 | Notice sign: "Close hood" | 1 | 199-01-155 |
| 26 | Notice sign: "Attention! Maintenance position Danger! " | 1 | 199-01-532 |
| 27 | Notice sign: "Attention! Discharge conveyor protection! " | 1 | 199-01-563 |
| 28 | Notice sign: "Functions of the hand pump" | 1 | 199-01-1067 |
| 29 | Notice sign: "Hydraulic flail shaft extractor" | 1 | 199-01-209 |
| 30 | Notice sign: 3-way valve position: Crushing flap/ flail shaft extractor | 1 | 199-01-330 |
| 31 | Notice sign: "Hood lift/lower via Motor/ Hand pump" | 1 | 199-01-558 |
| 32 | Notice sign: "Rotation block" | 1 | 199-01-1073 |
| 33 | Notice sign: "Cylinder block" | 1 | 199-01-1074 |

3.1.4.3 Illustration labels and warning signs

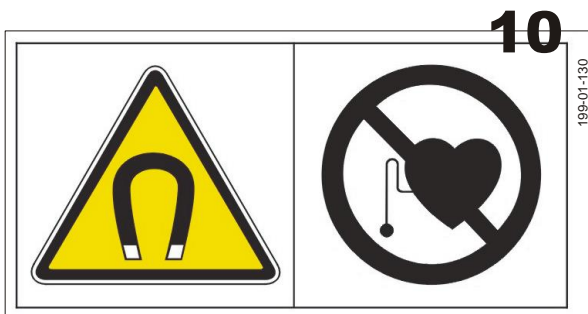

13



Prior to any repair, maintenance or cleaning work make sure the engine is switched off. Main battery switch must be in "OFF" position.

Engage clutch only when engine is running at low speed.



Before initial operation read operating- and safety information carefully.

Use operating supplies in accordance with the manufacturer's information.

199-01-132

14



15

Abbreviated Operating Instructions for WILLIBALD Shredder

(Extract from the operating instructions)

Safety: for details, see operating manual

- Never climb into a running machine.
- Danger zones during shredding: at front and rear in the longitudinal (material may be thrown from the machine), and in the area where loading takes place.
- Do not start the engine when safety devices are open.
- Raise the bonnet until the bonnet lock engages.
- When accessing the shredder rotor, please note: wait for the rotor to stop completely (after-run for a few minutes!)
- When accessing the endless floor, secure the draw-in roller with locking bolts.
- Apply the brakes on sloping terrain and use additional wheel chocks.
- Do not remove any safety devices. No technical modifications may be carried out without the previous consent of WILLIBALD.



Placing the Machine into Service: see also operating instructions

- Align the machine - make sure the surface is as level as possible.
- Ignition key in position 1 and wait until the control has started up.
- Turn the ignition key to position 2 and start the engine.
- Move the discharge conveyor to the working position.
- Press on wheel drive (attention -> wheel drive is not a brake - also apply parking brake).
- Auto-start (clutch on, engine goes to full throttle, intake and discharge conveyor switch on).

Machine loading: see operating manual

- Radio remote controls must always be in possession of the operator.
- Check shredding material for rough foreign objects prior to feeding, if necessary by dumping the first bucket loads onto the ground.
- Assure uniform feeding to the shredder and avoid overloading. (frequent reversal of direction of endless floor and feed roller = incorrect loading).

Switch off the machine: see operating manual

- Auto-Stop (infeed and discharge conveyor switch off, engine goes to idle).
- Auto-stop (switch off clutch).
- Move the discharge conveyor to the transport position.
- Spring the wheel drive away - apply the brake beforehand.
- Switch off the engine.

Regular maintenance and care of the machine is very important.

Daily measures: see operating manual

- Check levels: diesel, Ad Blue, engine oil, cooling water, hydraulic oil, grease.
- Manual lubrication points / Lubricate the feed roller bearings.
- Drain the condensation water on the intercooler.
- If necessary, clean the air filter, radiator and engine several times a day.
- Regular inspection of: rotor, tools, milling strips, scrapers, power belts, sensors, screws, discharge belt, conveyor guide rollers.
- See the separate maintenance and lubrication plan.

ATTENTION: Do not let the machine run unnecessarily in idle, risk of contamination of the particle filter.

Further maintenance and service: see operating manual

- Please refer to the separate lubrication and maintenance plan to find out which maintenance and other service work is regularly required on the WILLIBALD processing machine.
- Optimal use of the shredder can be guaranteed, if all necessary maintenance work is carried out completely and regularly only.

If necessary, our service is available for all questions and support. (See the adjacent QR code with the Willibald phone number).



We wish you safe working with the WILLIBALD shredding machine.

199-01-1218

16

Fuchs Renolin
CLP 320
3,5 L

199-01-369

17



Attention!
Lubricating nipple

199-01-306

18

Ladder

199-01-161

19

Diesel fuel only

199-01-159

20

Tire pressure
 $p_{max} = 8,5 \text{ bar}$

199-01-136

21



Hydr. pump lever



199-01-167

22

Schrauben nachziehen
Retighten bolts
Reserrer les boulons
Apretar los tornillos
Controllare il serraggio delle viti

199-01-139

23

199-01-1227

24



ATTENTION!
"Hood protection"
Open hood always completely

Hood protection

199-01-156

25

Close hood

- Open hood completely via manual pump.
- Pull down red handle and hold it.
- Put manual pump to "OPENNING" hood will come down. After abt. 20 cm let handle go.

199-01-155

26



199-01-532

27

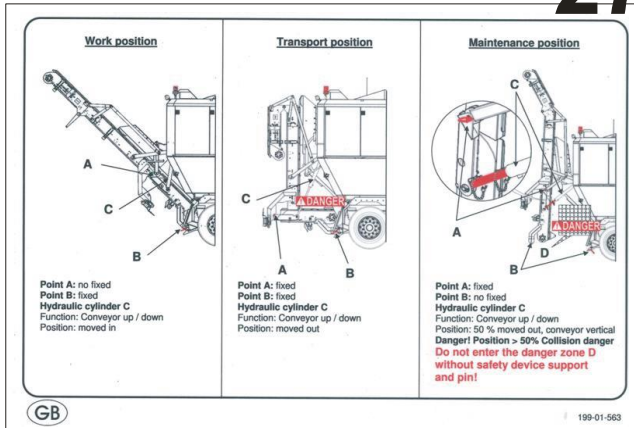

28

Hand pump operation:

1. Unscrew the red button on both seat valves on the cylinder block of the desired function.
2. Execute the function in the desired direction by operating the hand pump and setting the lever on the hand pump.

Normal operation:

3. Close all seat valves on the cylinder block by turning to the right.

199-01-1067 GB

29



30



31

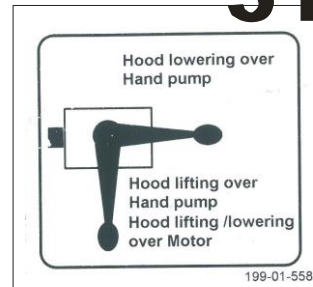

32

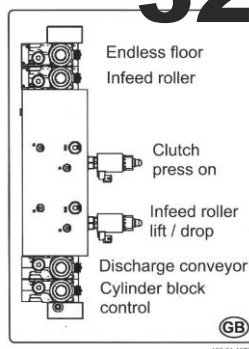

33

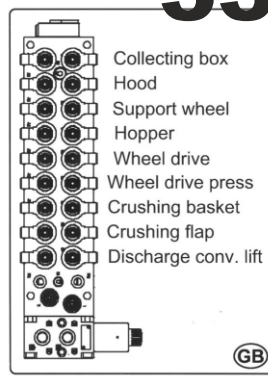

3.1.4.4 Position of the stickers on the machine



6 18 15 13 7 14 12 11



15 7 13 14 20 2 21 12



18 22 20 30 3 18 1 10



9 8 19



6

5



22

24

25



18

4

3

18



18

29

30

22

16

17

3.2 SAFETY INFORMATION and potential dangers in the use of the machine

3.2.1 Protective devices

WARNING

Danger of non-functioning protective devices

- Emergency stop device must be always freely accessible.
- Make sure and control each time before actuation of the machine that all safety devices and protective gear are mounted properly and operative;
- Safety devices and protective gear mounted at the machine may only be removed after complete standstill and only if the machine has been protected against restart;
- In case of delivery of part components, the operator is responsible too that safety devices or protective gear will be mounted and installed as prescribed.

3.2.2 Safety measures in normal operation

- Operate the machine only if sure that all safety devices and protective gear are fully operative;
- Before activation of the machine, make sure that nobody can be injured or endangered by the starting machine;
- Control the machine at least once per shift for visible damages at the outside and check for functionality of safety devices and protective gear.

3.2.3 Machine control

NOTICE

Danger of property damage due to incorrect handling of the control



- The control cabinet must be kept always locked.
- Instructed personnel are authorized to operate the machine control only

3.2.4 EMERGENCY STOP device

The emergency stop device is connected so that during interruption of power supply, or the activation energy supply after an interruption, dangerous situations for persons and property are excluded.

Emergency stop device must be always freely accessible.

WARNING

Danger of non-functioning safety devices

Safety devices ensure maximum safety during operation. Safety devices must not be overridden when work processes will complicate due to safety devices. The security is guaranteed when safety devices are intact only.

- Checks before starting work, all safety devices are installed properly and functional.
- Checks before starting the motor, all safety devices are installed properly and functional.

Two stop buttons are mounted on the machine. If one of those, or the one on the control, will get pushed in, the engine will Stop immediately.

The activated stop button will stay engaged until it will get unlocked through a clockwise rotation under tension.

*Illustration 3.1
EP 5500 Shark
Emergency off button*

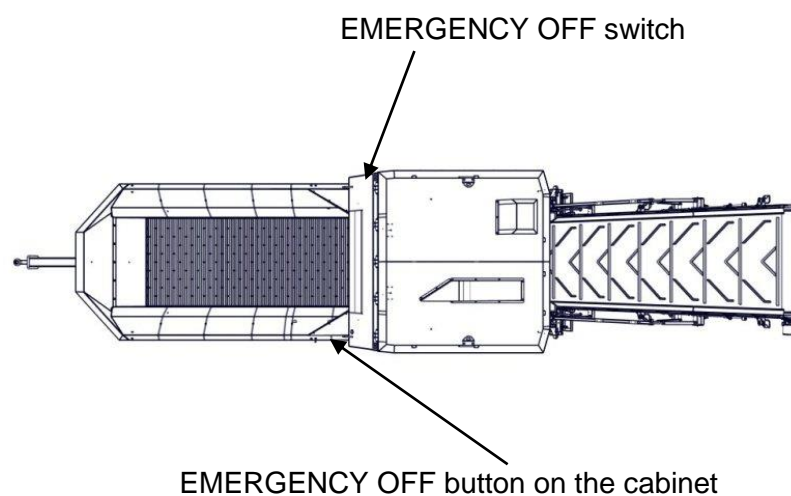

3.2.5 Dangers caused by electric energy

DANGER**Danger due to electrical current**

In case of contact with live parts is immediate danger to life.
Damage the insulation or components can be fatal.

- All works on the electric system must be performed by an expert electrician only;
- Check the electric equipment of the machine regularly.
- Immediately repair and eliminate loose connections and/or cables that are charred through;
- Make sure the switch cabinet is always kept closed. Access is allowed to authorized personnel only;
- In case works on voltage carrying parts or components of the machine need to be performed, provide for a second person's presence that can turn the main switch off in case an emergency situation occurs;
- Before performing any maintenance, cleaning and repair work, switch off power supply and secure against restart.

3.2.6 Dangers caused by hydraulic energy

WARNING**Dangers caused by hydraulic energy**

The hydraulic energy can cause serious or even fatal injuries.
Hydraulically driven components can move unexpectedly.

Due to damage of individual components, hydraulic fluid can leak under high pressure.

- Only specially skilled and experienced personnel familiar with it may work on the hydraulic systems of the machine;
- Before performing any repair works, get free the pressurized system sections and pressure lines that have to be opened for these works;
- Replace hydraulic hoses in appropriate intervals, even if no safety relevant deficiencies can be detected.

3.2.7 Passing out of noxious steams and gases

WARNING



Danger of escape of hazardous gases and vapors

The machine is equipped with a diesel engine that can be emitted during operation of the harmful gases and vapors. The integrated exhaust and filter system prevents at normal use of the machine the escape of harmful substances and gases and ensure compliance with legal limits.

- Mobile shredding units with Diesel generators must not be operated in closed rooms.

3.2.8 Noise level produced by the machine

WARNING



Hearing damage from noise

The sound pressure level produced by the machine exceeds 83 dB (A). Depending on the local operation conditions, a noise pressure level may be produced that can cause noise deafness.

- The operation personnel must in both cases be protected by corresponding safety equipment or safety measures.



3.2.9 Service and maintenance, elimination of faults

WARNING



Danger of injury due improperly performed maintenance, inspection and repair work!

Before performing any service routines, inspection or repair works, make sure the machine is completely off circuit (Illustration 3.2) and the main switch of the machine has been protected against unintentional restart.

- All maintenance operations are carried out in accordance with maintenance schedule;
- Compliance with all time intervals or reaching a certain number of operating hours;
- Take prescribed attitude, maintenance and inspection work punctually and register into the list on the page 111,

- Inform the service personnel before beginning of the maintenance,
- Secure against unintentional start-up all components and operating media such as compressed air and hydraulics,
- Mount and save carefully with lifting witnesses the larger building groups by the exchange,
- Control the solved bolt connections for tightness,
- After completion of the maintenance works or service routines, check all safety devices and protective gear for proper functioning.

3.2.10 Constructional modification of machine

- Never modify the machine or mount any attachments whatsoever without the manufacturer's prior consent. Same also applies for any welding performed on load carrying parts of the machine;
- All modifications whichever are subject to prior written consent by the company J. WILLIBALD GmbH;
- Any machine parts found being not in perfect condition must be replaced immediately;
- Use Willibald-original spare and wear parts only.

Only our approved original spare parts are checked by us and thus have the suitable conditions for the use of the machine. Third-party components is not guaranteed that they are designed to load and safety requirements and manufactured.

WARNING



Danger of injury by improper replacement parts

Incorrect or faulty spare parts can cause damage, malfunction or failure and impair safety.

- Use Willibald-original spare and wear parts only.

NOTICE



Give in all messages and inquiries the machine chassis number.
Order replacement parts by dealers or direct from WILLIBALD.

3.2.11 Cleaning of machine and disposal

Regular cleaning is a basic condition to the preservation of service life and functional capability of the machine. Use approved cleaning agents only.

The cleaning agents must be coordinated with the appropriate material, which should be examined before starting work. The corrosion protection should not attack parts. In general, acids and crude detergent, and solvent-based cleaners are unsuitable and can cause irreparable damage.

To clean should find as possible wetting agent solution with a pH 5-8. Ask the manufacturer in case of doubt on the suitability of the cleaning agent.

All media, stuff and materials must be applied, handled and disposed in the appropriate manner, which particularly applies in regard to

- any works performed on greasing systems and lubrication contrivances
- Cleaning agents used for cleaning purposes.

3.3 WARNINGS and special dangers in the use of the machine

3.3.1 Fire hazard in motor compartment

Highly flammable materials - diesel fuel, oils and fats

WARNING



Fire hazard due to highly flammable materials!

Pieces of wood and wood dust are inflammable!

Fuel and hydraulic fluid are inflammable!

Dirt accumulations in the motor compartment may lead to the break-out of a fire.

- Check the Motor compartment regularly for the accumulation of dirt and other dangerous contaminants. If need be, but at least once every day, clean it using compressed air.
- Before each motor start-up, both the fuel- and the hydraulic system must be checked for damages and/or leakages.
- If the fuel- and/or hydraulic system have incurred damages or leaks, repair and eliminate these defects.
- Pieces of wood, wood chips and dust as well as all other substances of a combustible nature must be removed by all means!
- Cleaning is permitted with the switched off motor only.

This label is located on the left side of the machine in the direction of travel, above the control cabinet:

Description: Warning of fire hazard! Read before commissioning instructions and safety information.

3.3.2 Fire hazard by replenishing with fuel

WARNING



Fire hazard due to highly flammable materials!

Smoking and naked flames forbidden!

Fuel is inflammable!

- Do not smoke while handling with fuel. Always make sure that nobody is smoking in the vicinity or handles with open fire.
- Replenishing is admitted with the motor in stopped condition only.

This label is located on the diesel fuel tank.

Description: Warning of fire! Fire, naked flame and smoking are banned!

3.3.3 Danger resulting coolants -antifreeze and anti-corrosion agent



WARNING

Risk of injury from coolants harmful to health

Coolant contains substances that are harmful to health.

- Observe and follow the safety data sheets of the manufacturer.
- When handling coolant, use always wears protective clothing, chemical resistant gloves and safety goggles.
- Avoid spilling and mist formation.

3.3.4 Damage resulting from crystallized reducing agent AdBlue® (Carbamide)

NOTICE

Component damage resulting from crystallized carbamide

The reducing agent AdBlue® is a non-combustible, colorless-and odorless, water-soluble fluid. The freezing point lies at -11°C.

AdBlue® is classified as non-dangerous.

The reducing agent crystallizes on drying.

On non-stainless steels and non-ferrous heavy metals AdBlue® has a strongly corrosive effect (triggering rust).

- The reducing agent must be immediately washed from metallic surfaces (sheet and aluminum, and also painted) with clear, hot water.
- All components, which come into contact with carbamide, must be immediately rinsed in hot water after disassembly and dried with compressed air.

This label is located on the carbamide tank.

Description: Attention corrosive material AdBlue®!



CAUTION

Irritation of skin and eyes

Contact with AdBlue® can cause despite all precaution an accident.

- Reducing agent must not be allowed to come into contact with the skin, eyes or clothing.
- Change the filter when wearing protective gloves and protective eyewear only.

With high temperatures in the tank (over approx. 50°C, e.g. due to direct sunlight) the reducing agent decomposes. This can lead to the generation of ammonia vapor (pungent smell).

- Do not inhale this vapour.

Ammonia

Ammonia is a colorless, pungent smelling gas.

Inhalation of vapors irritates and is corrosive to mucous membranes and eyes. Brief inhalation can cause inflammation in the airways or pulmonary edema.

WARNING



Danger to health from ammonia vaporous

If AdBlue® / DEF comes into contact with hot surfaces or temperatures that are too high in the tank as a result of leaks, a leaking SCR system, ammonia fumes form.

- Make sure that there is sufficient ventilation.
- Immediately switch off machine with a leaking SCR system.
- Rinse any equipment or the adjacent components with plenty water if it has they have come into contact with gas.

3.3.5 Dangers due to hot surface or liquid

CAUTION



Risk of burns from hot surface or liquid

Contact with hot components can cause burns.

- Always wear protective clothing and gloves when working near hot components
- Prior to working to ensure that all components have cooled to ambient temperature.

3.3.6 Dangers due wiring harnesses and plug connections

NOTICE

Material damage due to mishandling

Damage to the engine control unit, cabinet

- When installing connectors, first fully open the gripping device and then insert the connector and lock.
- Protect disconnected plug connectors and contacts from the ingress of dirt.
- Test wiring harnesses and plug connectors using suitable test equipment only.

3.3.7 Danger due to strong magnetic fields

WARNING**Danger to life due to strong magnetic field in machines with magnetic metal separators**

The EP 5500 Shark can be constructed with the metal separator with magnet roller as an option.

Strong magnetic fields can cause serious injury or death, as well as considerable property damage.

- People with pacemakers should not be in the vicinity of the metal separator. The function of the pacemaker could be affected.
- People with metal implants should not be in the vicinity of the metal separator. Implants can heat up or be attracted.

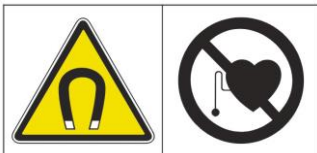

18901-150

This label is located on both sides of the machine when the machine is equipped with metal separator.

Description: Attention Magnet!

3.3.8 Danger by filling the machine

CAUTION



Danger caused from flying parts at filling the machine.

The EP 5500 Shark cannot be filled by hand!

Falling back material can cause injuries

- Use for the filling of the machine a tractor or loader.

WARNING



Drawing-in danger across moving endless floor and rotating in-feed roll

The EP 5500 Shark should not be entered to fill!

Movable endless floor on top and bottom side and rotating in-feed roll can cause serious injury.

- Make sure nobody stays within the danger zone (Illustration 2.2 Danger zones) of the EP 5500 Shark except operator with tractor or loader when starting the motor!
- Make sure that nobody can succeed into the danger area of the EP 5500 Shark except operator with tractor or loader when the machine is running!
- Use for the filling of the machine a tractor or loader.



This label is located on both side of the machine.

Description: Never walk on the loading area when the motor is on!

This label is located on both side of the machine.

Description:

Never walk on the loading area when the motor is on!



Obstacle above, danger place!

3.3.9 Danger by hydraulic feed-hopper

WARNING



Crushing hazard in area of hydraulic feed-hopper!

The hydraulic hopper in the filling trough may cause the pivoting movements or on failure of hydraulic serious injury.

- Make sure nobody stays within the danger zone (Illustration 2.2 Danger zones) of the EP 5500 Shark when starting the motor!
- Make sure that nobody can succeed into the danger area of the EP 5500 Shark when the machine is running!

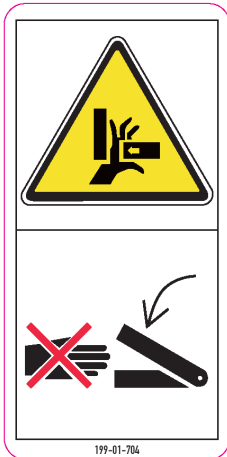

This label is located on the both side of the machine.

Description: Never reach into the crushing danger area as long as parts may move.

3.3.10 Danger by discharge conveyor

DANGER

Crushing hazard in area of discharge conveyor Danger of injury due moving discharge conveyor

Linearly moving parts can cause serious injury.

- During operation, no moving parts to interfere or tamper with moving parts.
- Make sure nobody stays within the danger zone (Illustration 2.2 Danger zones) of the EP 5500 Shark when starting the motor!
- Make sure that nobody can succeed into the danger area of the EP 5500 Shark when the machine is running!



This label is located on the both side of the machine

Description: Attention trap-door! Do not stand in the swing area of devices

3.3.11 Danger due rotating rotor

DANGER



Danger due rotating rotor!

The rotor will be running for several minutes after switching off the motor, and all dangers existing, when the motor is running will last on!

- Do not come into the draw-in and discharge area of the EP 5500 Shark!
- Before starting the motor makes sure that there is no person between the rotor and discharge conveyor.

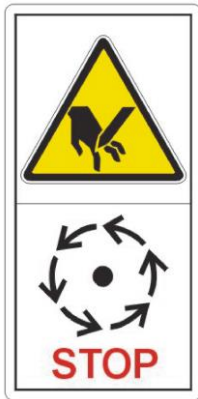

This label is located on the both side of the machine

Description: Attention rotating parts! Machine parts can be touching when they are stopped completely only.

3.3.12 Danger due rotating idler roll and power belt

DANGER

Drawing-in danger and crushing hazard due rotating idler roll and Power belt!



The drive motor brings the rotor in motion and the rotor rotates at very high speed. Therefore, the pulley and power belts are protected with a fixed fairing.

No care these suggestions can have duty effects of health, till vital wound with and without death result.



- The motor must never be started, until on all protect parts for the power belt fixed are screwed.
- Perform maintenance work when the machine is stopped only.
- Make sure that the machine cannot be started by unauthorized persons!

This label is located on the belt protection in on the right side of the machine direction of travel.

Description: Never open or remove safety devices with running motor.

4.0 FUNCTIONING

4.1 Processing task

The mobile shredding unit has been constructed and designed for the shredding and defibration of organic materials.

4.2 Construction (Illustration 4.1)

*Illustration 4.1
EP 5500 Shark
Construction*

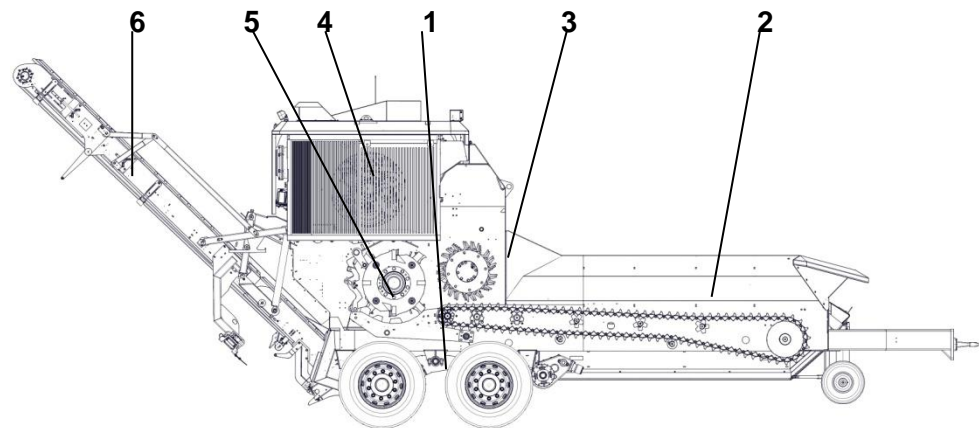

- | | |
|-------------------|--------------------------------|
| 1. Chassis | 2. Filling tub with leadership |
| 3. Draw-in roller | 4. Engine |
| 5. Shredding unit | 6. Discharge conveyor |

4.3 Functional principle (Illustration 4.2)

Loading the machine

The material is fed to the rotor via heavy duty floor conveyor (endless floor). The take-in height of the aggressive draw-in roller of up to 520 mm assures that bulky materials can be shredded, too.

Material infeed

The hydraulic drive of the heavy duty floor conveyor (endless floor) as well as the draw-in roller is infinitely variable, thus assuring optimum adaptation to the material to be processed.

The material is rough-pressed by endless floor conveyor and draw-in roller and then fed to the rotor.

Shredding the material

From top to bottom turning rotor reduces the material and supplies it to the cutting up basket. With the different basket positions as well as the flap position over hydraulic cylinders, can be adjusted the desired cutting up degree.

Discharging the material

After the crushing unit shredded material is discharged with the discharge conveyor.

The discharge conveyor allows shake out compost windrow heaps of up to 3.5 m (4.5 m optional) height. Advantages lie in the work safety in the ejection area, in easily stratification of the shredded material and higher heaps.

Illustration 4.2
EP 5500 Shark
Shredding unit
Functional principle
Variant EP 5500 Shark 5
V1 with 48 flails

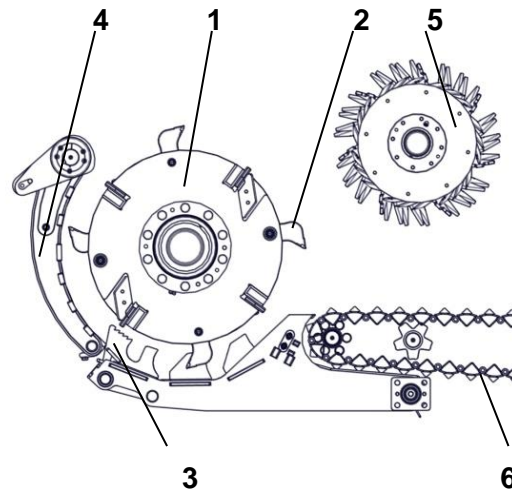

1. Rotor
2. Flail
3. Basket
4. Crushing flap
5. Draw-in roller
6. Endless floor

Shredding unit
Functional principle
Variant EP 5500 Shark 5
V2 with 40 flails

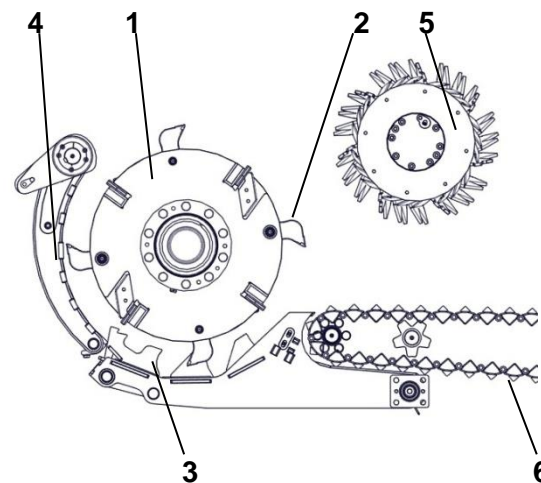

1. Rotor
2. Flail
3. Basket
4. Crushing flap
5. Draw-in roller
6. Endless floor

Shredding unit
Functional principle
Variant EP 5500 Shark 5 -
V3 with 16 flails

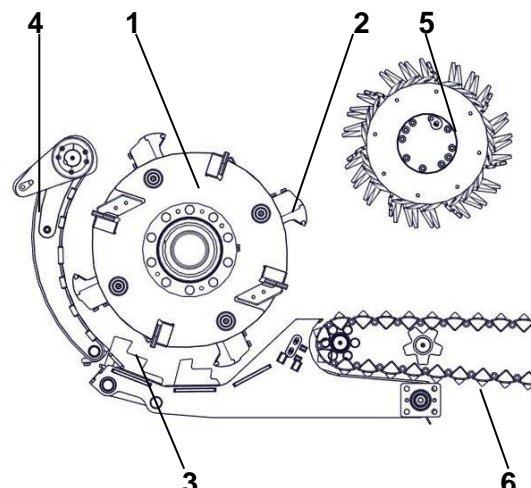

1. Rotor
2. Flail
3. Basket
4. Crushing flap
5. Draw-in roller
6. Endless floor

Shredding unit
Functional principle
Variant EP 5500 Shark 5
– V4 with 32 flails

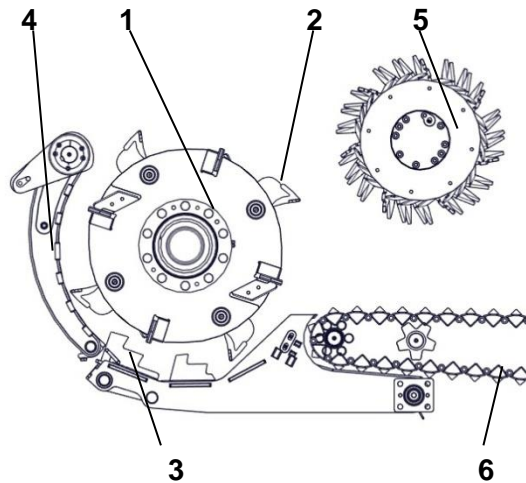

1. Rotor
2. Flail
3. Basket
4. Crushing flap
5. Draw-in roller
6. Endless floor

Shredding unit
Functional principle
Variant EP 5500 Shark 5
– V5 with 10 flails

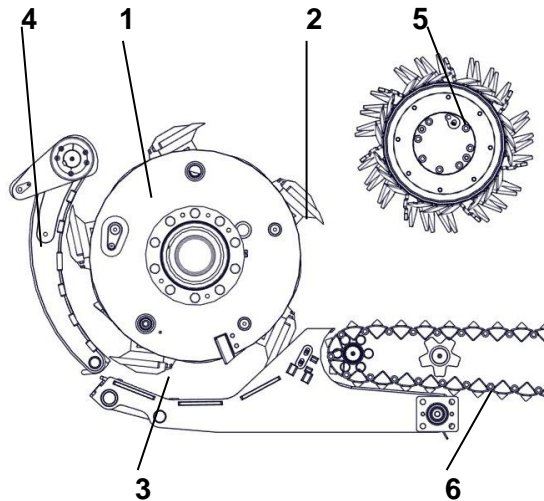

1. Rotor
2. Tools
3. Basket
4. Crushing flap
5. Draw-in roller
6. Endless floor

Emergency off button on the control cabinet



Emergency off switch



Emergency stop button on the radio



Green LED



4.4 Safety equipment

4.4.1 Emergency off button

Two stop buttons are mounted on the machine. If one of those, or the one on the control, will get pushed in, the engine will Stop immediately.

The activated stop button will stay engaged until it will get unlocked through a clockwise rotation under tension.

4.4.2 Emergency stop button on the radio remote control

The emergency stop button is on the radio remote control.

If this key is pressed, the engine will get switched off, hydraulic functions, the central lubrication and the fuel pump will get turned off. After undershoot of the revolution limit the coupling will get disengaged.

4.4.3. Main battery switch

The main electronic battery switch is located in the control cabinet. The electronic main battery switch switches off the machine after all waiting times have elapsed. The extinguished green LED next to the ignition switch signals this condition.

4.4.4. Siren

Siren

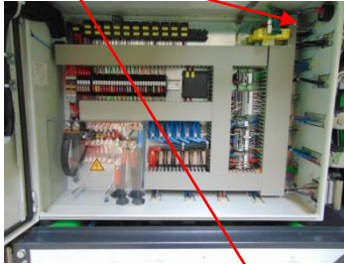

A siren is attached to the machine. The siren is located on the left side in the direction of travel of the machine next to the control box. The siren switches on, if a command from the control cabinet or radio remote control is triggered for functions.



4.5 Safety equipment for maintenance and repair work

4.5.1 Motor hood securing



Motor hood securing

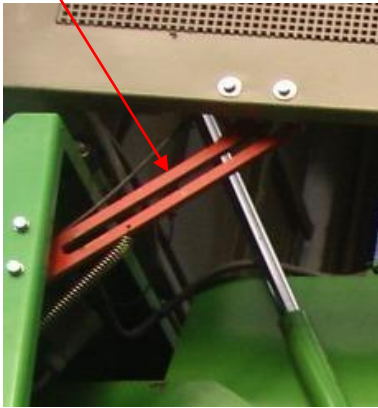

Bolt is engage

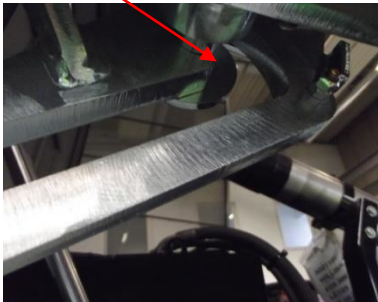

WARNING

Crushing hazard due to open and closed the hood!

Lowering the hood can result in serious injury to death.

Therefore hood is equipped with a hood securing.

For all maintenance and repair work the hood can be opened.

On opening the hood of the bolt must fully engage in the bore of the safety bar. In this case, the hood is completely opened and secured.

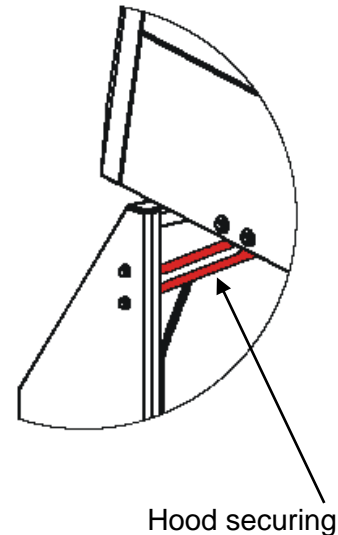
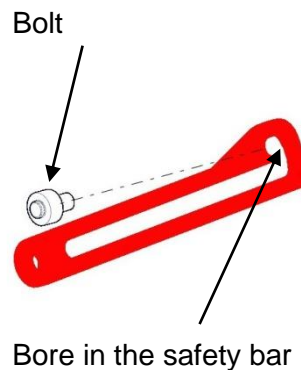

No person must be at and under the hood when it is lowered!

4.5.2 Coupling securing



WARNING

Crushing hazard by all maintenance and repair work!

The rotor is no longer balanced if the plug-in shaft is removed by pulling it out. The rotor will turn! For all maintenance and repair work without coupling securing the rotor could start to move and cause serious injury.

- Perform maintenance and repair work when the machine is stopped only.
- Before performing any maintenance or repairs the coupling cylinder must be secured with securing rod and bolts.

Securing rod

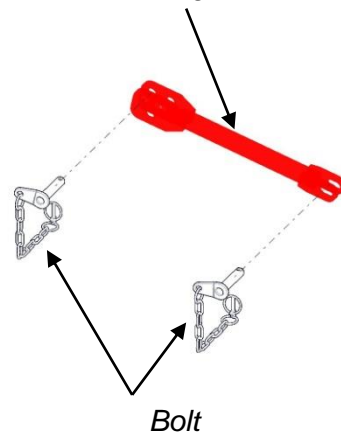

Bolt

Coupling securing

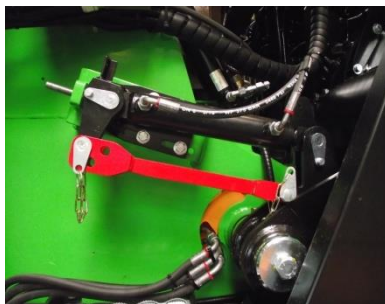

The hydraulic cylinder must be move in. A message "clutch disengaged" comes at the control cabinet.

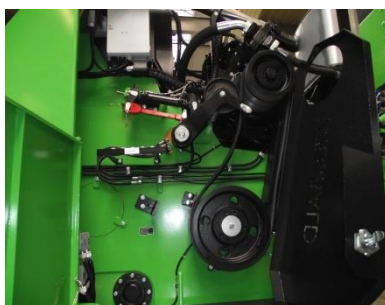
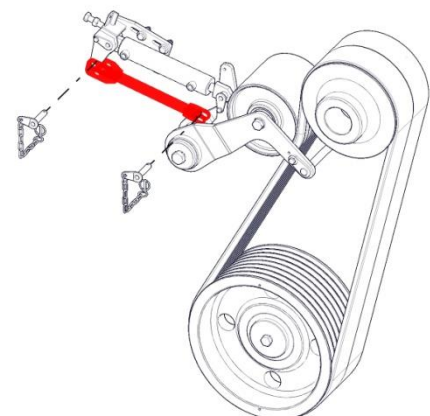

The securing rod must be attached at the hydraulic cylinder and fastened with bolts, so that the hydraulic cylinder does not extend.

4.5.3 Infeed roller securing

WARNING



Crushing hazard by all maintenance and repair work in draw-in area!

For all maintenance and repair work, the infeed roller must move hydraulically to top in order to achieve better the rotor or crushing basket

Infeed roller is down without Bolt



Bolt



When the infeed roller is in motion, this can cause serious injury.

- The infeed roller must be staked out after moving up with the bolt.

Infeed roller is moved up and staked out with bolt



Bolt



4.5.4 Discharge conveyor securing



DANGER

Danger of crushing in all maintenance and repair work!

There is a free space, danger zone D, between crushing unit and discharge conveyor at maintenance position. When the hydraulic cylinders come in motion, is occurred mortal danger to human life.

Not enter the danger zone D without cylinder lock! (Support rod (1) and bolts (2) both sides)

- Read and follow the description of security measures before you start maintenance and repair work. See Chapter 7, Point 7.7.

Securing discharge conveyor cylinders maintenance position



Bolts

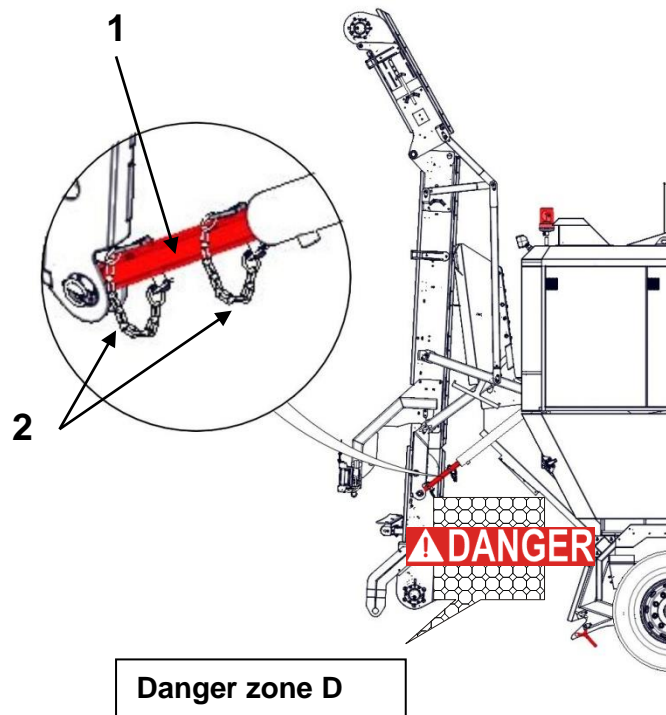

- Insert the support rod on both sides over hydraulic cylinder;
- Put the safety bolts in each hole of the support rod.
- Secure the bolts with the lynch pin, the pins are on secure bolts.

5.0 OPERATION MANUAL T-Wision

See separate operating instructions in the machine documentation, point 2.

6.0 COMMISSIONING / START-UP

6.1 Introduction

CAUTION

Thoroughly read and observe all information, warnings and safety notes contained in this operation manual *before* commissioning and start-up of the machine!



Keep this operation manual always ready to hand and, in case the machine is sold or ownership is transferred otherwise, make sure to pass it on to the new owner(s)!

Comply with all relevant rules and prescriptions operative and in force in regard to accident prevention by all means. Also make sure to comply with all generally acknowledged rules and prescriptions on safety technique, industrial medicine and road traffic.

Strictly observe the indicated servicing intervals!

You avoid accidents, dispose the machine ready for operation and have got the manufacturer's warranty.

DANGER



Drawing-in danger across moving endless floor and rotating infeed roll

Movable endless floor and rotating infeed roll can cause serious injury.

- Nobody must stay on the endless floor, when starting the motor!
- Make sure nobody stays within the danger zone (Illustration 2.2, Danger zones) of the EP 5500 Shark during maintenance work!
- Make sure that the machine cannot be started by unauthorized persons!



DANGER

Danger of rolling away the EP 5500 Shark

The EP 5500 Shark weighs about 19 tons and when the machine is in motion unintentionally, can result in serious injury to death.

- Take care of approximately horizontal place!
- When commissioning the EP 5500 Shark, always make sure that EP 5500 Shark is secured against rolling away!



WARNING



Crushing hazard due to open and closed the hood!

Lowering the hood can result in serious injury to death.

- Nobody must stay in the danger zone during commissioning!
- No person must be at and under the hood when it is lowered!

DANGER



Danger due rotating rotor!

Danger caused from flying parts during working at the machine

The shredded and defibrated material, the caused by foreign bodies (for example stones) is thrown out of the EP 5500 Shark at very high speed!



- Nobody must come into discharge area of the EP 5500 Shark.
- Before starting the motor makes sure that there is no person between the rotor and discharge conveyor.
- Make sure nobody stays within the danger zone (Illustration 2.2 Danger zones) of the EP 5500 Shark when starting the motor!
- Make sure that nobody can succeed into the discharge area of the EP 5500 Shark when the machine is running!

DANGER



Drawing-in danger and crushing hazard due rotating idler roll and Power belt!

The drive motor brings the rotor in motion and the rotor rotates at very high speed. Therefore, the pulley and power belts are protected with a fixed fairing.

No care these suggestions can have duty effects of health, till vital wound with and without death result.



- The motor must never be started, until on all protect parts for the power belt fixed are screwed.
- Make sure that the machine cannot be started by unauthorized persons!



DANGER

Crushing hazard in area of discharge conveyor Danger of injury due moving discharge conveyor

Linearly moving parts can cause serious injury.

- During operation, no moving parts to interfere or tamper with moving parts.
- Make sure nobody stays within the danger zone (Illustration 2.2 Danger zones) of the EP 5500 Shark when starting the motor!
- Make sure that nobody can succeed into the discharge area of the EP 5500 Shark when the machine is running!

WARNING

Hearing loss from noise

The noise level of the EP 5500 Shark is approximately 83 dB (A).

NOTICE

During operation of the EP 5500 Shark has therefore always have suitable hearing protection must be worn.

CAUTION

Irritation of the eyes

Danger to your eyes because throwing out of the particles and due to increased production of dust while operating the EP 5500 Shark.

NOTICE

Always wear appropriate safety glasses, therefore!

6.2 Transport of the EP 5500 Shark

What is to be checked?

The following items must be assured, checked and controlled each time before driving on a public road:

Illustration 6.1

Transport EP 5500 Shark

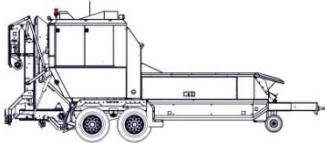

Transport position



- Are the chassis and EP 5500 Shark at the licensing office registered?
2. Are the permissible trailer weight at the towing vehicle sufficient, in order to pull the EP 5500 Shark?
 3. Has the EP 5500 Shark been coupled properly to the trailer coupling of the towing vehicle?
 4. Is the trailer couplings ring in good condition?
 5. Are the screws existing at the hitch of the EP 5500 Shark properly fixed and does not damage?
 6. Are the two braking air hoses undamaged and correctly connected with the towing vehicle?
 7. Are the plugs for the driving electrical connection put into the appropriate plug socket at the towing vehicle?
 8. Is the discharge conveyor in transport position?
 9. Is the lighting bar installed, and put and secured the pins for the lighting bar?
 10. Does lighting, turn signal, brakes function?
 11. Are the side flaps and sides doors right fixed?
 12. Does the prescribed tire pressure exist in all 4 wheels?
 13. Is the parking brake unlocked?
 14. Is the wheel drive disengaged?

15. Is the button existing at the brake air distribution of the EP 5500 Shark pressed (position "open"). (Illustration 6.2) and is it engaged? It is assume, when wheel drive is checked.

*Illustration 6.2
EP 5500 Shark
Brake air distributor*



Brake air distributor

WARNING



If the EP 5500 Shark of a towing vehicle without ABS is pulled or if the ABS at the towing vehicle or at the EP 5500 Shark is defective, must be counted during a danger braking on a longer stopping distance.

The total weight of the EP 5500 Shark will approximately 19 t and in such case the EP 5500 Shark needs to be equipped with an antiskid system for the operation brakes of the running wheels.

If the EP 5500 Shark is pulled by a towing vehicle, which is equipped with an ABS, the plug for the ABS must be put into the existing plug socket at the towing vehicle?

The efficiency of the ABS is indicated in the towing vehicle during a control light. If the ABS works correctly, this control light must expire at a speed of max. 10 km/h. If the light does not expire, a authorised workshop is to be visited.

It is permitted with a total weight over 13 tons a transport in connection with towing eye by 50 mm in diameter only!

*Illustration 6.3
EP 5500 Shark
Start-up of the machine*

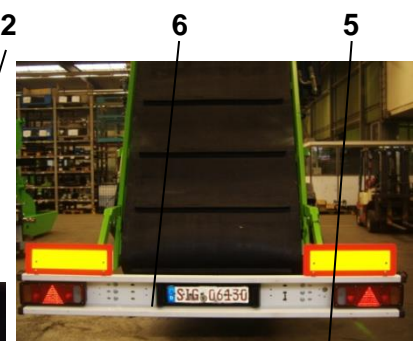
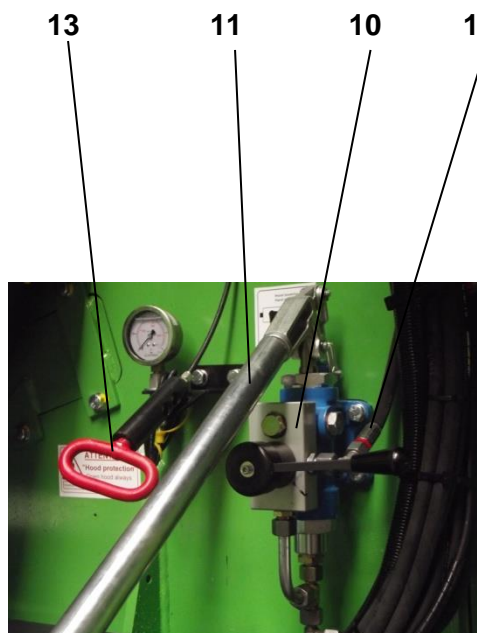
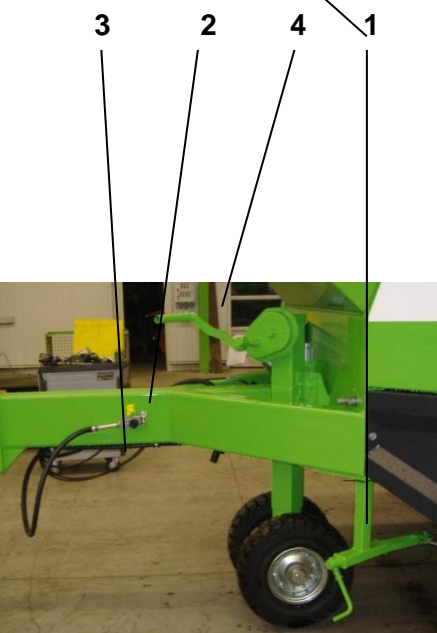
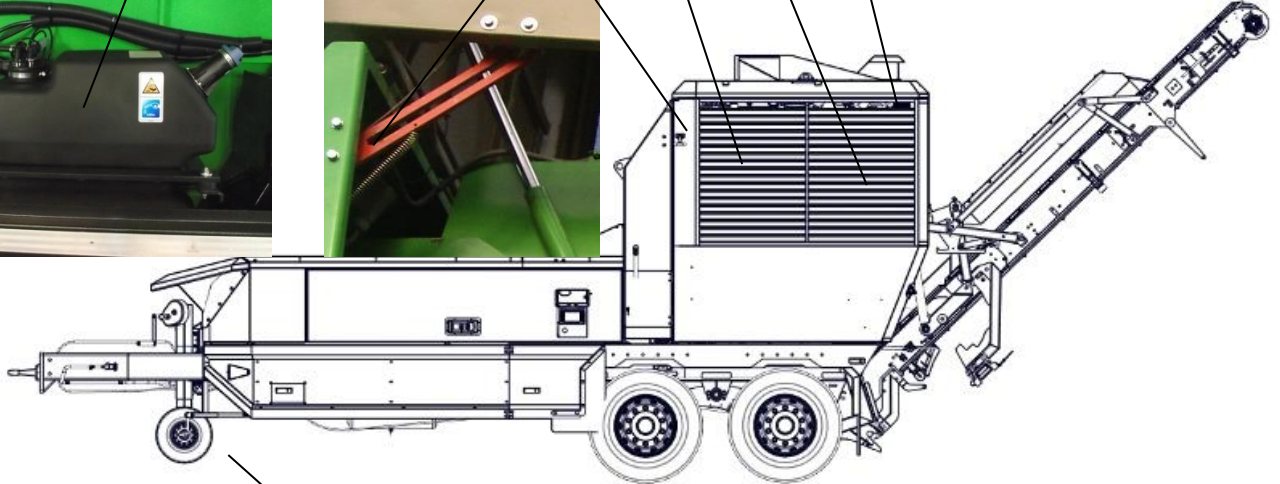
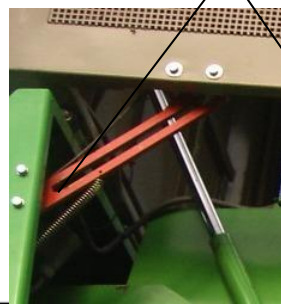
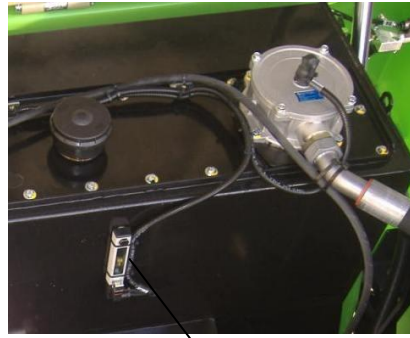
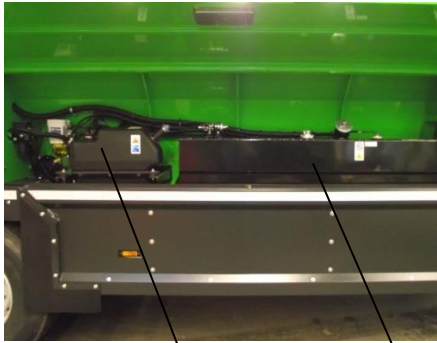

6.3 Start-up of the machine (Illustration 6.3)

6.3.1 Safety information

NOTICE



Read and observe the general safety and the safety instructions in this chapter before starting work.

The instructions must be followed and you must act cautiously to avoid accidents, personal injury and property damage.

The commissioning of the machine must be carried out by staff of WILLIBALD or by WILLIBALD trained personnel only.

WARNING



Danger of incorrect commissioning

Commissioning requires trained personnel with sufficient experience. Errors in the start-up can lead to life-threatening situations and lead to significant property damage with it.

- Commissioning is carried out by WILLIBALD employees.
- Also of WILLIBALD trained personnel should carried the commissioning with permission of WILLIBALD only.

6.3.2 Setting up the EP 5500 Shark

Pull the EP 5500 Shark to the provided operation place.

Take care of approximately horizontal place!

- Block the locking brake by turning the crank handle (1) clockwise.
- Disconnect and remove both brake lines (2) from the towing vehicle.
- Unplug all trailer cables (3) from the towing vehicle.
- Lower the wheel drive during turning the crank handle (4), that is no more necessary the trailer jack on the towing vehicle, alternatively during hydraulic wheel drive.
- Uncouple the EP 5500 Shark from the towing vehicle,
- Pull out the lighting plug (5), lighting bar (6) remains at the conveyer.

6.3.3 Motor hood opening



WARNING

Crushing hazard due to open the hood!

Lowering the hood can result in serious injury to death.

- No one must be in the danger zone during opening the hood!
- Do not carry out commissioning if the hood has not engaged in securing the hood.

Opening the hood occurs in the following steps:

1. Fold out discharge conveyor into the working position.
2. Switch at the hand pump (10) valve lever (12) downwards.
3. Pump up the hood with manual lever (11) until the hood is open complete.

Hood lifting /lowering over Hand pump

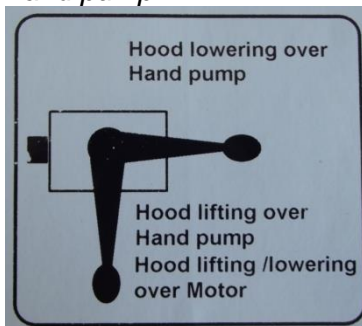

Switch valve level downwards



Switch valve level to right

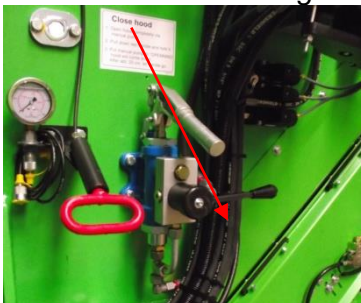

Bolt is not engaged in the hood securing.

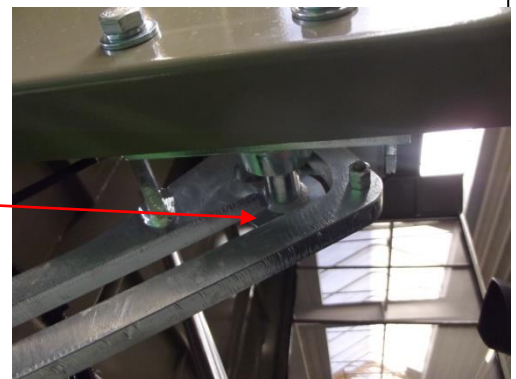

5. Switch the valve lever to right.

6. Then close the hood until the hood bolt in the hood securing (14) engages.

7. Switch the valve lever (12) back down.

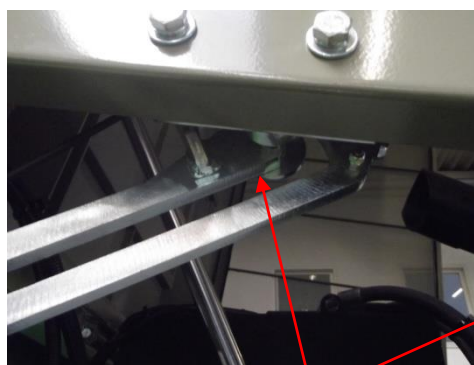

Bolt is engaged in the hood securing.

The hood is completely opened and locked.



Filling socket 2



Level indicator 1

Check of hydraulic oil, engine oil level and fuel level before any operation. Refill hydraulic oil, engine oil, diesel fuel if necessary.

6.3.4 Checking the hydraulic oil level

Check the hydraulic oil level.

The level indicator (1) on the side of the hydraulic tank shows the hydraulic oil level. Oil level must lie between the markings "min." and "max". If the oil level is too low, (2) of hydraulic oil filling socket fill up until the "max." is reached (See chapter 8.7 types of oil).

WARNING

Fire hazard due to highly flammable hydraulic oil!

Hydraulic oil is inflammable!

Dirt accumulations in the motor compartment may lead to fire hazard and severe to fatal injuries.

- Fill hydraulic oil, when the motor is switched off only.
- Ensure cleanliness in the motor compartment. Cleaning is permitted with the switched off motor only.
- The hydraulic system should be checked before starting the motor for damage and leaks.

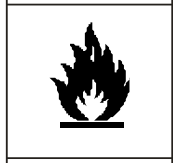

NOTICE

Extinguishing the warranty claims due to non-approved oils!

When using non-approved oils will extinguish the warranty claims. (See chapter 8.7 types of oil).

- Use the authorized fuels use only.

6.3.5 Checking the motor oil level

Check the motor oil level (8).

- Pull out the dipstick of the motor and wipe off that with clean rag.
- Insert the dipstick to the end stop again and pull out that again. Oil film on the dipstick must end between markings "min." and "max". If necessary, fill up with motor oil (motor manual).



NOTICE

Component damage caused by overfilling

Motor damage can occur when filling of motor over the max-marking.

- Motor oil does not fill over the max mark on the dipstick.

6.3.6 Checking the diesel fuel level

Check the diesel fuel level (9).



WARNING

Fire hazard due to diesel fuel

Diesel fuel is inflammable!

- No smoking and no open fire when handling fuel.
- Refuel when the motor is switched off only.
- Ensure cleanliness in the motor compartment.
- Do not spill the diesel fuel.



The fuel level is seized by a float with resistance giver in the tank. The announcement of the control shows the current condition. (See operating instructions t-Wision). A tank filling is enough for approx. 8-10 h.

6.3.7 Checking the coolant level

Closing cap



Check the coolant level (15).

- Unscrew the closing cap that has no lead seal.
- The cooler is properly filled, when the refrigerant reaches up to the upper edge of the opening at the surge tank.



CAUTION

Risk of burns from hot surface or liquid

- Check coolant at a coolant temperature below 50 ° C only!

6.3.8 Checking the AdBlue® - System

When the first commissioning, ensure that:

- AdBlue® has a quantity of at least 15 litres in the tank.
- work area is clean and in order.
- coolant pipes, compressed air lines and carbamide lines are checked for sealing.

NOTICE



Component damage caused by overfilling

AdBlue® freezes at temperatures below -11 ° C and expands. Therefore, there is a risk of damage due to overfilling of the AdBlue® tank.

- Do not overfill the carbamide tank (15).

6.3.9 Motor hood closing

WARNING



Crushing hazard due to close the hood!

Lowering the hood can result in serious injury to death.

- No person must be at and under the hood when it is lowered!
- Nobody must be stay in the danger zone at closing the hood.

Closing the hood occurs in the following steps:

1. Open the hood complete with hand pump, so that that is put out of the hood securing.

Valve lever shows downwards.



Switch valve level to right

2. Pull the red lever and turn the valve lever to the right.

Hood closes automatically.

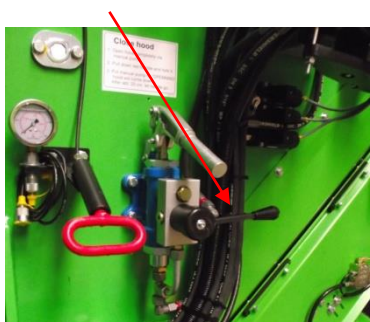

7.0 OPERATION

General safety information

The operation of the machine must be performed by trained personnel or by professional staff only.

WARNING



Danger of incorrect operation

Improper operation can cause serious person or property damage.

- Make sure before starting work, all covers and safety devices are working properly.
- Never use safety equipment during operation except power.
- Ensure cleanliness and tidiness in the work area! Loosely superposed lying parts and tools are sources of accidents.

7.1 Starting, short description

DANGER



Danger of injury due moving parts

Linear motion components can cause serious or even fatal injuries.

- During operating, the machine must be monitored permanently and it may be turned away at short time only.
- Eye contact must exist always, when the moving pull up equipment is in use.
- Check, that nobody stays within the danger zones of the machine (Illustration 2.2).

NOTICE



Danger due to incorrect starting

- See operating instructions t-Wision.
- Check that there is nothing lies in the fill trough.
- The parking brake is light don when building is not even!

- Check, that nobody stays within the danger zones.
- Set the ignition switch to position "1".
- The controller boots when the Willibald logo appears
- After the boot process, the display is briefly dark and then initializes the display pages, during which time a loading bar is displayed.
- Set the ignition switch to position „2“,
- When the motor does not start, interrupts the starting procedure after maximally 20 seconds and repeat after approximately 1 minute.
- Let the motor run and warm up.

The complete system is switched to automatic mode:

- Press the button  on the control cabinet.

In the automatic start process, the clutch is engaged one after the other, the discharge conveyor is switched on, the engine is run at full throttle and the infeed roller and endless floor are switched on. See operating instructions T - Wision.

Couple the rotor on and out with idling speed only!

WARNING



With operation the machine via radio control the operator must be able to the access the control panel, the located right side of the machine as well as the EMERGENCY-OFF switches provided at both sides of the machine (Illustration 2.2) at any time without any risks).

7.2 Adjustments (Illustration 7.1)

Infeed roller, wheel drive, endless floor, discharge conveyor

There are two control blocks in the machine: cylinder block and rotation block. The rotary block has valves for regulating the speeds of the infeed roller, wheel drive, endless floor and discharge conveyor.

Turning it to the right will reduce the speed, turning it to the left will increase it.

The endless floor conveyor and infeed roller are proportionally regulated (current controlled).

The speed of the endless floor and infeed roller is regulated independently by the engine management

Illustration 7.1

Rotation block

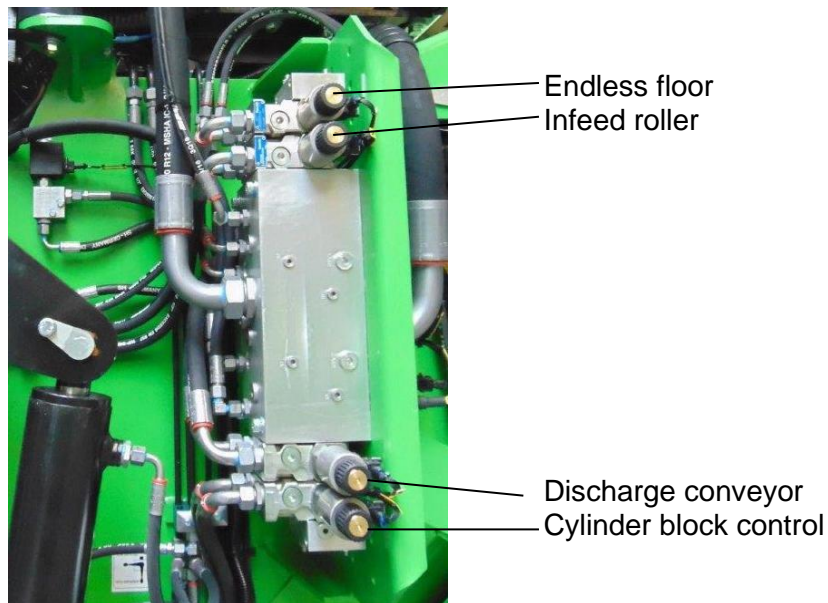

Cylinder block

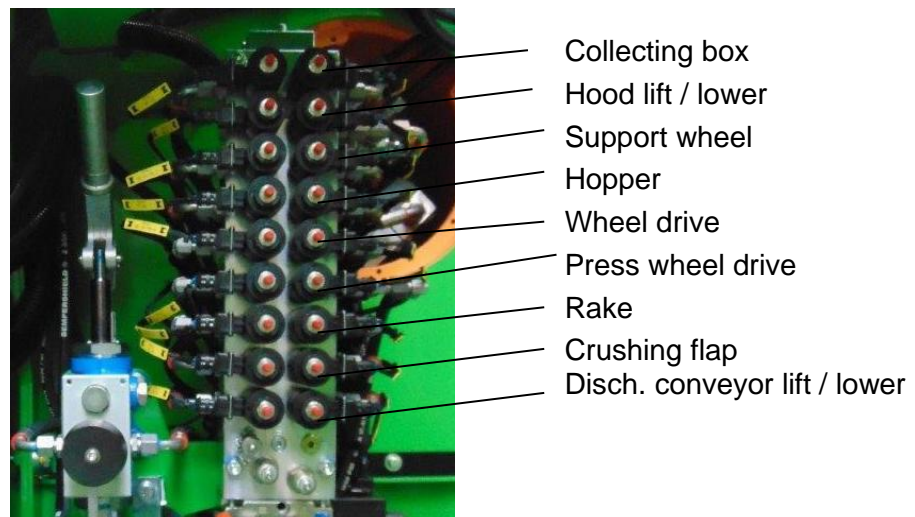

7.3 Turning out, short description

DANGER



Danger due rotating rotor!

The rotor will be running for several minutes after switching off the motor, and all dangers existing, when the motor is running will last on!

- Do not come into the draw-in and discharge area of the EP 5500 Shark.

Danger caused from flying parts during working at the machine

The shredded and defibrated material caused by foreign bodies (for example stones) is thrown out of the EP 5500 Shark at very high speed!

- Nobody must come into discharge area of the EP 5500 Shark.
- Before starting the motor makes sure that there is no person between the rotor and discharge conveyor.
- Make sure nobody stays within the danger zone (Illustration 2.2 Danger zones) of the EP 5500 Shark when starting the motor!
- Make sure that nobody can succeed into the discharge area of the EP 5500 Shark when the machine is running!

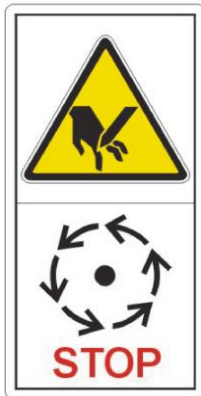

Turning out:

Read operating instructions t-Wision

- Press the key .
- The system switches to the OFF state. This is shown on the display. Attention! The rotor is still engaged!

7.4 Emergency-off function

Several **EMERGENCY-OFF push buttons** have been provided at the machine. If one of these buttons was pushed, the motor will be stopped immediately and all hydraulic drives are taken out of service (Operating instructions t-Wision

Motor and power belts are very strong charged, when the EP 5500 Shark switched off with EMERGENCY-OFF push button. EMERGENCY-OFF push buttons may therefore be activated in an emergency case only and must not be used for normal switch-off.

Such, the following emergency cases could occur:

- Imminent danger that persons might get into the pull in and discharge area of the EP 5500 Shark or on the endless floor conveyor.
- Danger that material which - by reason of its size, nature and structure - cannot be defibrated, might get caught by the draw-in rollers (e.g. big stones, metallic objects etc.)

Illustration 7.2
V-belt protection is closed



and locked with a lock



7.4.1 Press back the idler roll

After an emergency stop can the idler roller stay engaged.

For pressing the idler roller back:

Switch on ignition.

Run the motor briefly.

When motor is running, the rotor turns and the idler roller is pressed back by itself. In this case, the V-belt protection must be closed and locked.

(Illustration 7.2)

If, after an emergency stop, the motor cannot run, (for example, if the rotor is blocked), the following steps are necessary to restart:

- Eliminate a cause for the emergency.
- Idler roller must be relieved.

For this work the V-belt protection must be opened.

DANGER



Danger due to restarting by unauthorized persons!

Drawing-in danger across V-belts!

Ignoring this safety information can have heavy effects of health, till vital wound with and without death result.



- Make sure that the machine cannot be started by unauthorized persons!
- Perform maintenance work when the machine is stopped only.
- Motor must not be started with engaged idler roller!

Next steps:

- Open the motor hood over the hand pump,
- Open the protection door of the V-belts,
- Examine, that the hydraulically operated idler (clutch) is pressed and the power belts are completely relaxed. If this is not the case, the idler must be pressed with the help of a lever with switched on ignition upward
- Closed the protection doors of power belts.
- Start the EP 5500 Shark, proceed as described in Chapter 7.1, "Starting".

Illustration 7.3
EP 5500 Shark
Coupling

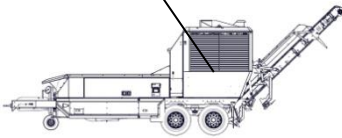
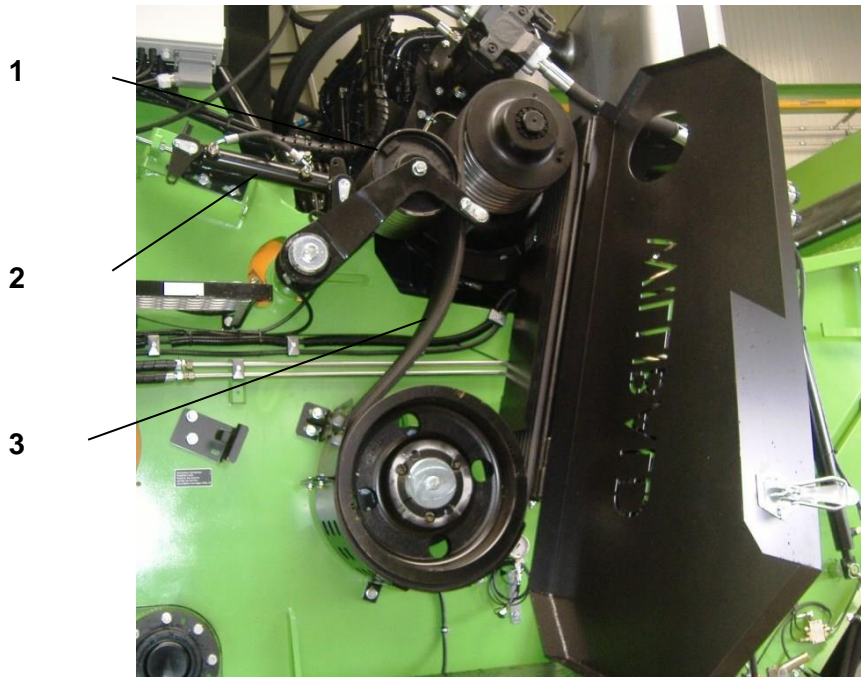

Illustration 7.3: Idler roll (1) is released, hydraulic cylinder (2) is completely to back repressed, the power belts are released



7.5 Transfer of machine

7.5.1 Machine without wheel drive



DANGER

Danger caused from flying parts during working at the machine

The shredded and defibrated material caused by foreign bodies (for example stones) is thrown out of the EP 5500 Shark at very high speed!

- No persons must stay in the danger zones (Illustration 2.2)!
- Nobody must come into discharge area of the EP 5500 Shark.
- Before starting the motor makes sure that there is no person between the rotor and discharge conveyor.

At its latest, the EP 5500 Shark must be transferred, i.e. driven away from the new formed compost windrow by some meters if the rotor starts scraping the new formed up windrow or if the windrow reaches the same height as of the discharge belt.

For this purpose, the EP 5500 Shark motor must not be turned off (stopped) (i.e. infeed roller, endless floor conveyor and discharge conveyor: STOP); however, it is recommended to reduce the motor r.p.m. down to no-load speed.



DANGER

Danger of rolling away the EP 5500 Shark

The EP 5500 Shark weighs about 19 tons and when the machine is in motion unintentionally, can result in serious injury to death.

- When transferring the EP 5500 Shark, always make sure both towing vehicle and EP 5500 Shark are protected against wheeling away!
- Use the Willibald wheel wedges to prevent rolling the machine.



- Couple the towing vehicle to the EP 5500 Shark.
- Protect the towing vehicle against rolling away.
- Release the locking brake of the EP 5500 Shark.
- Tow the EP 5500 Shark away from the compost heap by approx. 1-2 metres.
- Block locking brake of the EP 5500 Shark.
- Uncouple the EP 5500 Shark from the towing vehicle.

7.5.2 Machine with wheel drive

DANGER



Danger caused from flying parts during working at the machine

The shredded and defibrated material caused by foreign bodies (for example stones) is thrown out of the EP 5500 Shark at very high speed!

- No persons must stay in the danger zones (Illustration 2.2)!
- Nobody must come into discharge area of the EP 5500 Shark.
- Before starting the motor makes sure that there is no person between the rotor and discharge conveyor.

At its latest, the EP 5500 Shark must be transferred, i.e. driven away from the new formed compost windrow by some meters if the rotor starts scraping the new formed up windrow or if the windrow reaches the same height as of the discharge belt.

For this purpose, the EP 5500 Shark motor must not be turned off (stopped) (i.e. infeed roller, endless floor conveyor and discharge conveyor: STOP); however, it is recommended to reduce the motor r.p.m. down to no-load speed.

DANGER



Danger of rolling away the EP 5500 Shark

The EP 5500 Shark weighs about 19 tons and when the machine is in motion unintentionally, can result in serious injury to death.

- When transferring the EP 5500 Shark, always make sure both towing vehicle and EP 5500 Shark are protected against wheeling away!
 - Use the Willibald wheel wedges to prevent rolling the machine.
- Couple the towing vehicle to the EP 5500 Shark.
 - Protect the towing vehicle against rolling away.
 - Release the locking brake of the EP 5500 Shark.
 - Fold away the wheel drive.



But there are two possibilities: over switchgear cabinet or over radio. (See operating instructions t-Wision).

Disengaging the wheel drive: First press the grey release key: Display message: „Decontrol for releasing traction drive” than activate within 3 seconds the key for releasing the wheel drive.

Transfer the machine on the desired place now.

Clap the wheel drive again and work with machine as usually: motor is full throttle, draw in roll, endless floor and discharge belt on.

Engaging the wheel drive: Press the key until the wheel drive is completely engaged.

7.6 Turning of the EP 5500 Shark, start of new compost, windrow forming procedure

DANGER



Danger of rolling away the EP 5500 Shark

The EP 5500 Shark weighs about 19 tons and when the machine is in motion unintentionally, can result in serious injury to death.

- When transferring the EP 5500 Shark, always make sure both towing vehicle and EP 5500 Shark are protected against wheeling away!
- Use the Willibald wheel wedges to prevent rolling the machine.



A new compost windrow can now be stratified and formed. Before doing so, make sure to comply with all information, notes and danger sources indicated in Chapter 6.0 "Commissioning". Regarding the execution of the steps listed above, please observe Chapter 7.5.1.



- Couple the towing vehicle to the EP 5500 Shark.
- Release the locking brake of the EP 5500 Shark.
- Move the machine to another compost windrow.
- Block locking brake of the EP 5500 Shark.
- Uncouple the EP 5500 Shark from the towing vehicle.

7.7 Replacement of wear parts



WARNING

Danger of injury by improper replacement parts

Incorrect or faulty spare parts can cause damage, malfunction or failure and impair safety.

- No parts other than original **WILLIBALD** spare parts must be used to replace worn off wear parts. If otherwise, we cannot guarantee for the proper functioning and operating safety of the unit
- Before performing any of the works described in Chapter 7.7, make sure the motor is turned out and the main battery switch is in OFF position (Illustration 3.1).

By changing the wearing parts discharge conveyor must be brought into the maintenance position.

DANGER



Danger of crushing in all maintenance and repair work!

By maintenance work discharge conveyor must be brought into the maintenance position.

There are a free space between crushing unit and discharge conveyor at maintenance position. When the hydraulic cylinders come in motion, is occurred mortal danger to human life.

- No one is allowed to stay in the danger zone (Illustration 2.2 danger zones), as long as the discharge conveyor is moving!
- Do not perform maintenance and repair work without securing of the discharge conveyor cylinder.



7.7.1 Taking the discharge conveyor in maintenance position

Transport position



1. Take the discharge conveyor from the transport position to in the work position;

Function

„Conveyor lift / lower“

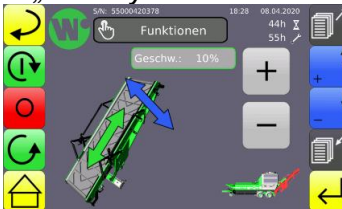

2. Select the function “Conveyor lift / lower, lift the conveyor



lift

moves in transport / working position

Intermediate position



Work position



Arm fix with bolts

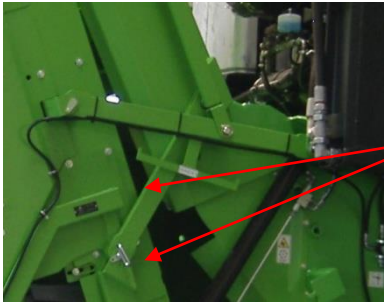

3. Attach the parallel arm into position and fix with bolts;

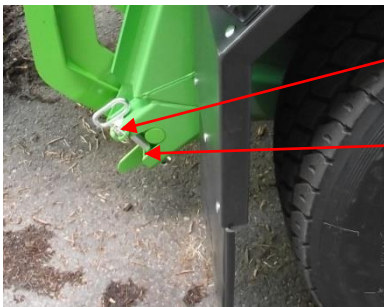

4. Open and pull out the lynch pin;

5. Remove the bolt;

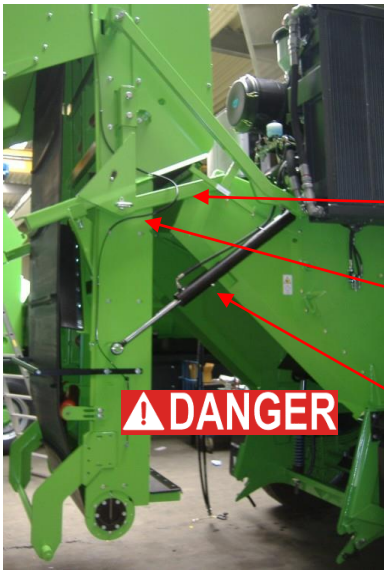

Control danger area, nobody may stay in danger area!

Parallel arm

Bolts

Hydraulic cylinder

Function

„Conveyor lift / lower“



6. Select the function "Conveyor lift / lower"

7.  lower moves in working position

8. Lower the discharge conveyor

CAUTION



Collision danger!

Caution! Press the button until the discharge belt has reached the vertical position only!

If the discharge belt is moved over the vertical position also, then touching the belt, the hood and it can cause damage!

A red marker will appear on the crushing unit. This means the end of the discharge conveyor movement.

Red marking

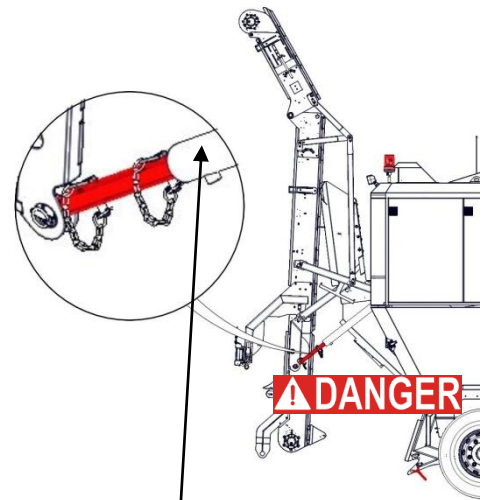

Hydraulic cylinder

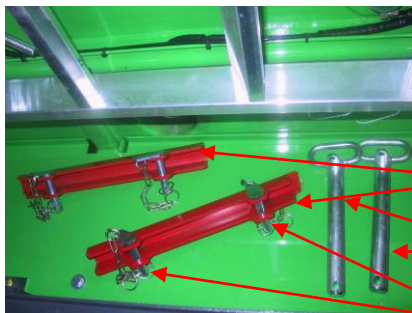

Position: 50 % moved out, discharge conveyor is vertical.

Position > 50% Collision danger

U-Profile (support rod)

Bolts

Linch pin

*Cylinder securing both sides
Bolts are inserted and with
linch pin secured*



8. Attach the U-Profile (Support rod) on both sides to the piston rod of hydraulic cylinder and secure with bolts and linch pin

The maintenance work can be begun, when cylinder securing is appropriate to both hydraulic cylinders of the discharge belt only, for example replacement of wear parts!

Illustration 7.4
 Drive off border of flail

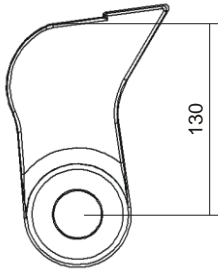

7.7.2 Replacement of flails

Imbalance leads to vibrations of the rotor. The with a wear below the driving off border of 130 mm of the flail turning point flails (illustration 7.4) lead to excessive energy expenditure and wear of the rotor, up to the imbalance. Therefore the flails must be changed with reaching the driving off border.



Danger by replacement of flails

DANGER

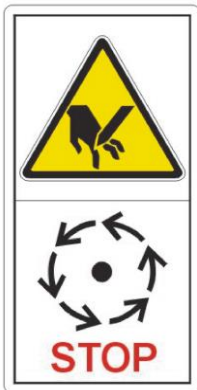

Danger due rotating rotor!

Danger caused from flying parts!

The rotor will be running for several minutes after switching off the motor, and all dangers existing, when the motor is running will last on!

- Do not come into the draw-in and discharge area of the EP 5500 Shark!
- Machine parts touch only when they are stopped completely.

WARNING



Coupling securing

Danger of crushing in all maintenance and repair work!

Danger of imbalance of the rotor!

The rotor is no longer balanced if the plug-in shaft is removed by pulling it out. The rotor will turn! For all maintenance and repair work without coupling securing the rotor, one could start to move and cause serious injury.

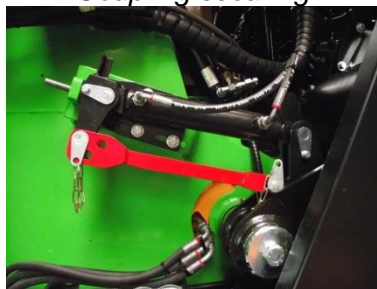

Securing of conveyors cylinder

- Perform maintenance and repair work when the machine is stopped only.

- Before performing any maintenance or repairs the coupling cylinder must be secured with securing rod and bolts.

- Before performing any maintenance and repair work both band cylinder must be secured with support rod and bolts.

- Replace the flails always in sets.

When replacing them, comply with the prescribed mounting

Illustration 7.5
Unscrew the cover plate

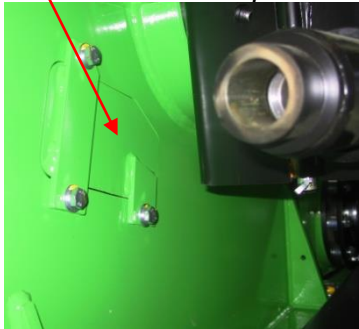

Threaded hole



Illustration 7.6
Remove the securing screw 3

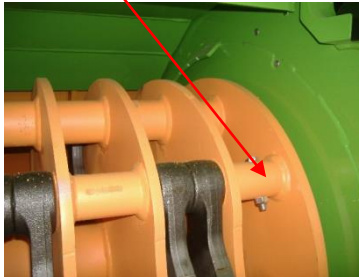

Illustration 7.7

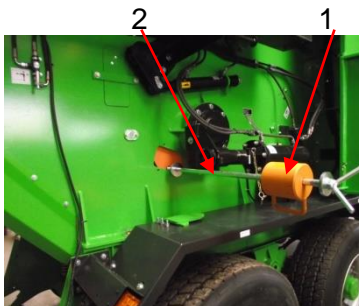

Illustration 7.8



The manual exchanging the flails

The flails can be manual or with hydraulic shaft pulling device (as extra option) exchanged.

1. Preparing the machine

- Let the EP 5500 Shark continue to work until the complete endless conveyor floor is empty.
- Tow the EP 5500 Shark away from the compost windrow by approx. 5 m.
- Open the hood and check that hood is engaged in hood securing.
- Crushing flaps drive upward and basket drive downwards.
- Bring the discharge conveyor in maintenance position.
- Turn the motor out.
- Turn the main battery switch "OFF" ("AUS"), (Chapter 7.3, Turning out, short description).
- Unscrew the cover sheet underneath of the rotor bearing (Illustration 7.5)
- Unscrew the safety screw (3) on the rotor plug-in shaft. (Illustration 7.6).

- Turn the rotor till a thread hole provided in the plug-in shaft becomes visible in the opening underneath of it.
- Clean the thread hole.

2. Remove old flails

- Screw tightly the guide bar (2) into the thread hole. (Illustration 7.7).

- Beat with the striking weight (1) the plug-in shaft from the rotor (Illustration 7.8).

Illustration 7.9



The flails fell to the lower basket (Illustration 7.9).

Illustration 7.10



3. Insert new flails

- Introduce the guide bar and the greased plug-in shaft again into the rotor and cautiously knock it in using the striking weight. (Illustration 7.10).
- Gradually, let your assistant slip the new flails in pairs onto the plug-in shaft.
- Make sure to comply with the prescribed mounting direction!

4. Insert next flails

- Screw the safety screw into the plug-in shaft again tightly.
- Screw the guide bar out off the plug-in shaft and turn the rotor until the next thread hole in the opening becomes visible;
- Now replace the flails as described here above.
- Screw the cover sheet (Illustration 7.5) down again underneath of the rotor bearing.
- Remove the securing of cylinders;
- Bring the discharge conveyor into work position.
- Turn main battery switch "ON" ("EIN").
- Turn the motor on.

Illustration 7.11

Examine the free run of the flails

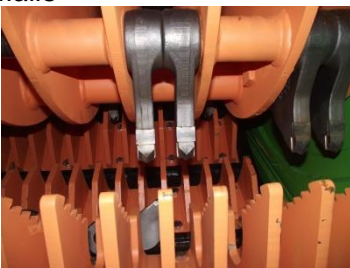

- Switch on the rotor; examine the free run of the flails (Illustration 7.11).

- If everything is correct, switch off the machine.
- Close the hood.

The exchanging the flails with hydraulic axle extractor

Illustration 7.12
Hydraulic axle extractor



Coupling securing

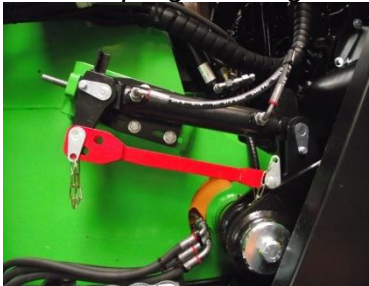

Securing of conveyors cylinder



Illustration 7.13
Fold out the pulling device

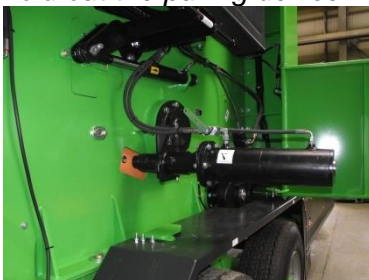

1. Preparing the machine

- Let the EP 5500 Shark continue to work until the complete endless conveyor floor is empty.
- Tow the EP 5500 Shark away from the compost windrow by approx. 5m.
- Open the hood.
- Start the machine.
- Bring the discharge conveyor into work position.
- Crushing flaps drive upward and basket drive downwards.
- Turn the motor out.
- Turn the main battery switch "OFF" ("AUS"), (Chapter 7.3, Turning out, short description).
- Unscrew the cover sheet underneath of the rotor bearing (Illustration 7.5)

2. Safety measure

- Bring the securing rod on clutch cylinder and secure with bolts,
- Close the belt protection.
- Block the crushing flap during ball cock.
- Attach the support rod over hydraulic cylinders of discharge conveyor and secure with bolts and linch pin.

3. Remove old flails

- Fold out the pulling device. (Illustration 7.13).
- Remove the locking screw on the plug-in shaft (Illustration 7.6).

Illustration 7.14

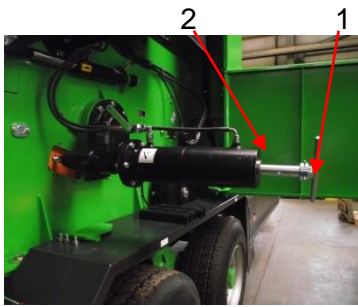

- Screw tight the auxiliary shaft (2) with the swing (1). (Illustration 7.14).
- Motor on; stand gas, rejust the panel on funk.

By distant control may be use the function “Crushing flap” or “Stop” only.

- During simultaneous pushing the “Crushing flap” on the radio control and opening hydraulic plug on the cylinder of one person, can be the shaft bit by bit pull out.

Illustration 7.15
Insert the distance sleeve



- After one full stroke come back the cylinder and apply the distance bush (3) and pull again. (Illustration 7.15).

- Screw out the auxiliary shaft after 3-Th bush; rescrew the swing (1) on the shaft.

- Pull out the plug-in shaft with the same step as the auxiliary shaft only.
- Motor Stop.
- Take out the plug-in shaft from pulling device, clean that, use possibly again.

4. Insert new flails

Two distance sleeves



- Fold on side the shaft pulling device.
- Built the new flails in pairs with one person.
- When replacing them, comply with the prescribed mounting directions.
- Screw the safety screw again.
- Repeat all step from the point “Fold out the pulling device” until all flails are exchanged.
- Motor Stop.

Three distance sleeves



- After changing the flails fold off the pulling device on side and screw that again.
- Screw the cover sheet on the light side of rotor again.
- Open the V-belt protection, delete the securing rod on the clutch cylinder, and close the V-belt protection.
- Open the crushing flap during ball cock.
- Motor on, stood gas.
- Turn the rotor on, check the free running of flails.
- If everything is correct, switch off the machine.
- Remove the securing of conveyors cylinder.
- Bring the discharge conveyor into work position.
- Close the hood.

The manual exchanging the flails by Rotor with 32 flails

Illustration 7.16
Rotor with 32 flails



Illustration 7.17
Flails

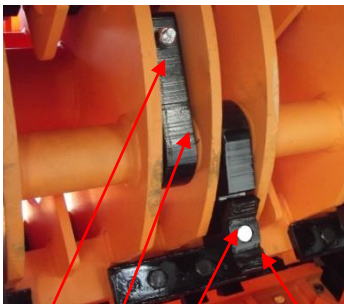

4 1 3 2

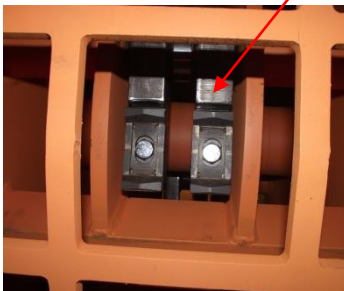

Illustration 7.18
Examine the free run of the flails



1. Preparing the machine

- Let the EP 5500 Shark continue to work until the complete endless conveyor floor is empty.
- Tow the EP 5500 Shark away from the compost windrow by approx. 5m.
- Open the hood.
- Start the machine.
- Bring the discharge conveyor into work position.
- Crushing flaps drive upward and basket drive downwards.
- Turn the motor out.
- Turn the main battery switch "OFF" ("AUS"), (Chapter 7.3, Turning out, short description).

2. Exchanging the tools

The flail consists of the main body (1), the exchange peak (2), the screws (3) and nut (4). Illustration 7.17

The exchange peaks reach the driving of border faster than flail main body and must be replaced.

The exchange peaks are replaced manually without pulling out the plug-in shaft.

- Turn the rotor manual and unlock the screws and nuts from tools;
- Exchange the exchanging peaks;
- Tighten the screw with torque 300 Nm

If the tools are changed, then:

Open the V-belt protection, delete the securing rod on the clutch cylinder, and close the V-belt protection.

- Open the crushing flap during ball cock.
- Motor on, stood gas.
- Turn the rotor on, check the free running of flails. Illustration 7.18
- If everything is correct, switch off the machine.
- Remove the securing of conveyors cylinder.
- Bring the discharge conveyor into work position.
- Close the hood.

3. Exchanging the flails completely

When the main body of the flails are worn, the plug-in shafts must be pulled out. See description exchanging the flails with 48 und 40 tools

Manual tool change for the rotor with 10 tools

Illustration 7.19
Rotor with 10 tools



1. Preparing the machine

- Let the EP 5500 continue to work until the complete endless conveyor floor is empty.
- Tow the EP 5500 away from the compost windrow by approx. 5m
- Open the hood and ensure that the hood is engaged in the hood catch.
- Crushing flaps drive upward and basket drive downwards.
- Bring the discharge conveyor into work position.
- Turn the motor out.

Illustration 7.20
tools



2. Rework and change tools

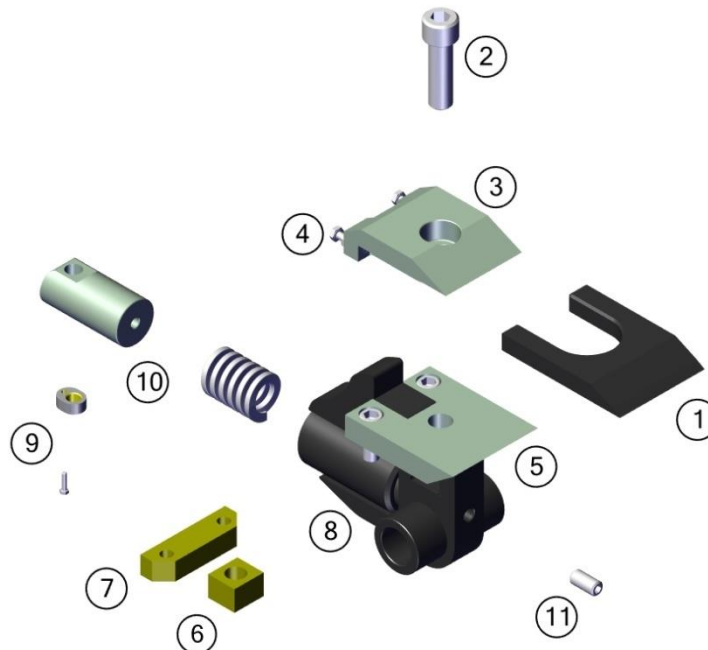

The toll consists of:

1. Blade
2. Tensioning screw
3. Clamp piece
4. Adjusting screw for blade
5. Blade support
6. Thread block for tensioning screw
7. Thread plate for blade support
8. Main body
9. Bolt nut with screw
10. Bolt with spring tension
11. Closing screw

If the blade 1 no cuts effectively, it can be reworked externally or in the rotor (grinding.) The blade loses its length and must be readjusted.

The adjustment of the tools takes place in the following steps:

- Loosen the tensioning screw 2, which presses with a tightening torque of 1500 Nm the clamping piece 3.
- Slide the blade into the working position using adjusting screws 4 on the back side of the blade. This is achieved when the kerf on the rake is 1-2 mm.
- Then press clamping piece 3 again with a tightening torque of 1500 Nm.
- All parts that are in the wear area of the blade are also changeable:
 - Clamp piece 3;
 - Blade support 5;
 - Thread block for clamping screw 6;
 - Thread plate for blade support 7;

3. Safety facility in foreign body's effect action (rotor safety facility)

The main body 8 can escape by excessive force due to tearing off the security screw 9. In this case, the bolt with spring tension 10 runs in the slot of the rotor down and is locked against pivoting back in a catch. To return to the normal position, a screw plug 11 must be removed under the blade receptacle in the front area. Using a long screw M16x200 10.9, the bolt must be pulled back against the spring force. Now bring the basic body back to the basic position, replace the safety screw, reactivate the bolt tension and place the closing screw).

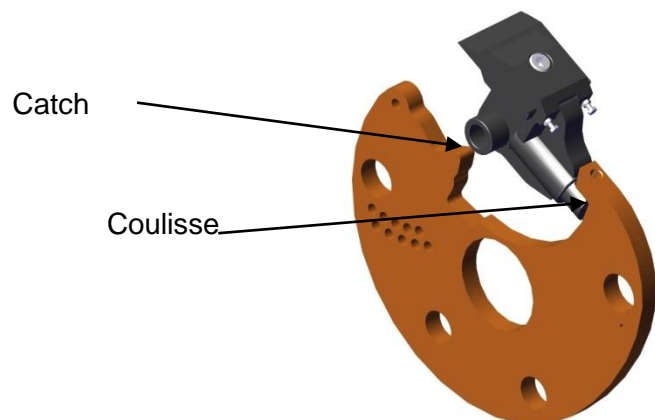

If the tools are changed, then:

- Turn the rotor on manually, check the free running of tools.
- Remove the securing of conveyors cylinder;
- Bring the discharge conveyor into work position.
- Remove securing sleeve over clutch cylinder, close belt protection.
- Close the motor hood.
- Motor on, idle speed.
- Turn on the rotor and check the free running of the tools.
- Switch on working speed.
- If no noise is heard from the rotor, then the blades are adjusted correctly.
- If noise from the rotor is audible, then the kerfs must be increased.

4. Change deflectors and scrapers

Deflectors and scrapers can also wear over time and be changed as needed.

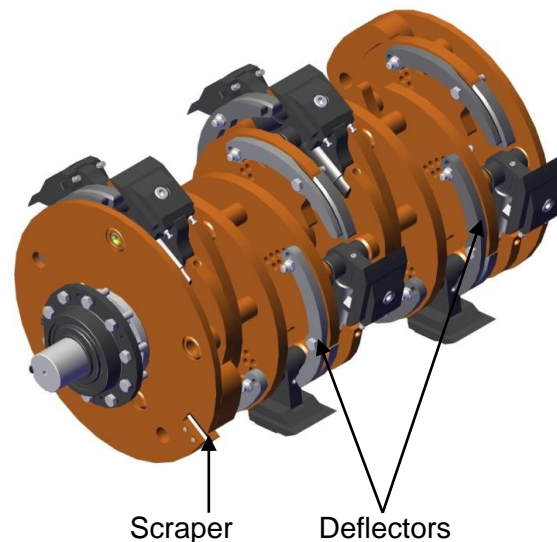

The deflectors are adjustable to a cutting gap: 50 mm, 40 mm, 25 mm.
The deflector has three holes to set the desired gap.

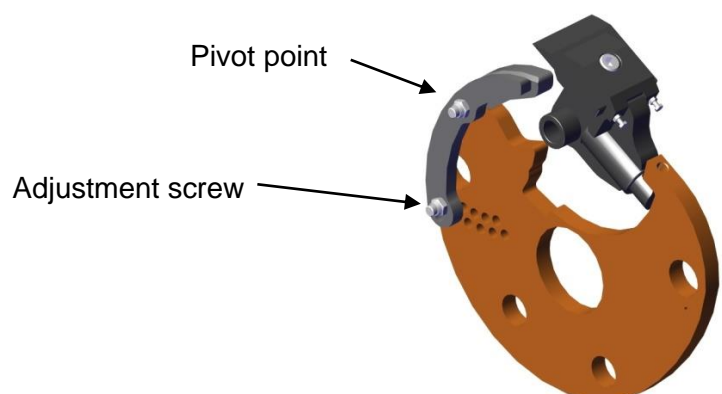



7.7.3 Replacement the rakes of crushing basket

WARNING

Danger of crushing by changing the rakes!

The rakes of crushing basket located in the catchment area of the machine, where are the infeed roller and rotor. If these parts come in motion, can be result in serious injury or even death.

- Replacement the rakes when the machine is stopped only.
- Make sure that the machine cannot be started by unauthorized persons!

Infeed roller securing



Securing of conveyors cylinder



- Lift the infeed roller high hydraulically and secure with bolt.
- Bring the discharge conveyor into maintenance position.
- Secure both discharge conveyor cylinders with support rod and bolts.

CAUTION



Danger of falling down of heavy rakes

The rakes weigh approximately 60 kg and if that falls, accidents can happen.

- Rakes should be by an assistant or a forklift removed from the machine.
- Secure the rake against falling down with ropes.

Screws

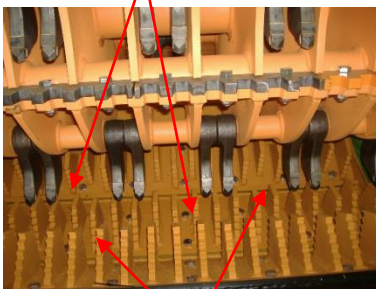

*Rakes
Nuts*

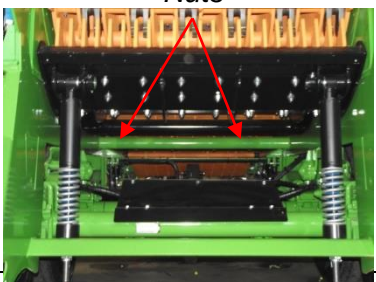

Rakes are changed according to the following steps:

- Turn the motor out;
- Turn the main battery switch "OFF".
- Loose the screw and nuts of changing rakes;
- Assistant with forklift removes the rake;
- Insert new rake and tighten slightly the screw.
- Turn the rotor slightly and examine the free run of the flails;
- Adjust the rake with the flails (move left or right).
- Tighten the screws finally;
- Remove the securing of conveyors cylinder.
- Bring the discharge conveyor into work position.
- Turn the rotor on, check the free running of flails again;
- Drive up the crushing flap;
- The machine is ready for operation.
- Check the screws for 5-10 hours for tightness.



7.7.4 Replacement of the shredding flap

DANGER

Danger zone by replacement of shredding flap



Crushing hazard due to discharge conveyor by replacement the shredding flap!

By replacement the shredding flap discharge conveyor must be brought into the maintenance position. Trained person must work in the danger zone. Without security of conveyor cylinders occurs deadly threat to human life.

- Replacement the shredding flap when the machine is stopped only.
- Make sure that the machine cannot be started by unauthorized persons!

Securing of conveyors cylinder



- Bring the discharge conveyor into maintenance position.
- Secure both discharge conveyor cylinders with support rod and bolts

Shredding flap is changed according to the following steps:

- Turn the motor out;
- Turn the main battery switch "OFF".

Screws and Nuts

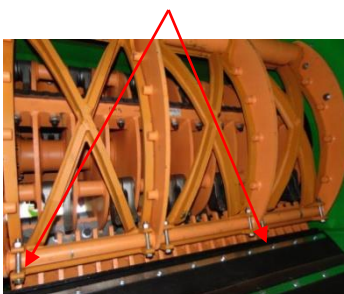

Crushing flap consists of two segments which are fastened with 6 screws (in each case 3 screws).).

- Loose the fixing screws;
- Remove the segments;
- Screw new segments;
- Tighten the screws finally;
- Remove the securing of conveyors cylinder;
- Bring the discharge conveyor into work position;
- The machine is ready for operation.

7.7.5 Replacement of power belt



DANGER

Drawing-in danger and crushing hazard due rotating idler roll and Power belt!

The drive motor brings the rotor in motion and the rotor rotates at very high speed. Therefore, the pulley and power belts are protected with a fixed fairing.

No care these suggestions can have duty effects of health, till vital wound with and without death result.

- The motor must never be started, until on all protect parts for the power belt fixed are screwed.
 - Perform maintenance work when the machine is stopped only.
 - Make sure that the machine cannot be started by unauthorized persons!
- Power V-belt is changed according to the following steps:

*Illustration 7.21
EP 5500 Shark
Replacement of power belt*



- Open the motor bonnet and secure it (Chapter 6.3.3, Motor hood opening).
 - The motor is turned out; the rotor stopped and stands still.
 - The main battery switch must be turned "OFF".
- Caution! The parts are weighty!
- Open and unhook the protective case (1), before parts be unscrewed.
 - Mark the place.

- Unscrew the lower belt protection (2).
- Loose the V-belt protection (3).
- Loose and pull out the screw (4).
- Hanging out the clutch cylinder.
- Press back the idler roll.
- Remove the used old power belts and fit new belts.
- Turn down the idler roll again.
- Screw the lower belt protection (2) and (3).
- Sling the coupling cylinder again.
- Check the distance between power belts and belt protection.
- Sling and close the protection flap (1). Make the trial run.
- Unsecured and close the motor hood.

Take care the power belt does run absolutely well. It must not graze at the belt guides!

7.7.6 Adjusting the angle sensor

*Illustration 7.22
Angle sensor*



The angle sensor is located behind the tension pulley fork.

At every service and from time to time in between on the machine, the clutch sensor must be checked to make sure it is in the correct position.

If the setting is not correct, either the shredder's automatic function will no longer work or the power belts are too worn.

DANGER



Danger of being pulled in and crushed by rotating tensioning roller and power belt!



When setting the angle sensor for the test run, the V-belt guard must be open. Caution! This poses a risk to people from the rotating tension pulley and power belts.

- This work may only be done by an authorized expert.
- Only perform this works when the rotor is stationary.
- Whenever work is to be done on the machine, switch off the engine and the main switch.

Adjustment

Carrying out weekly or when changing the power belt according to the maintenance instructions, chapter 8.1, point 9.

- Switch off the engine.
- Check that the clutch cylinder is completely retracted.
- Check operating lever position:

The actuating lever of the angle sensor points to approx. 11 o'clock (the threaded rod actuates the lever clockwise during the coupling process.), Adjust the position by changing the threaded rod.

- Saving the engaged value in the control:

If you switch from full throttle to idle while the clutch is manually engaged, the control system automatically saves the engaged position of the angle sensor. Once the save is completed, will be a short horn signal.

- Perform three times for safety following points:
 1. start the rotor manually.
 2. Speed at full throttle.
 3. Speed on idle.
 4. Wait until the horn sounds.
- Check the engaged position:
 1. Engage the rotor
 2. Coupling icon on radio transmitter flashes yellow
The coupling icon on the control display flashes green
 3. Power belt fully tensioned (rotor turns completely with)
 4. The coupling icon on the radio transmitter lights up green
The coupling icon on the control display lights up green.

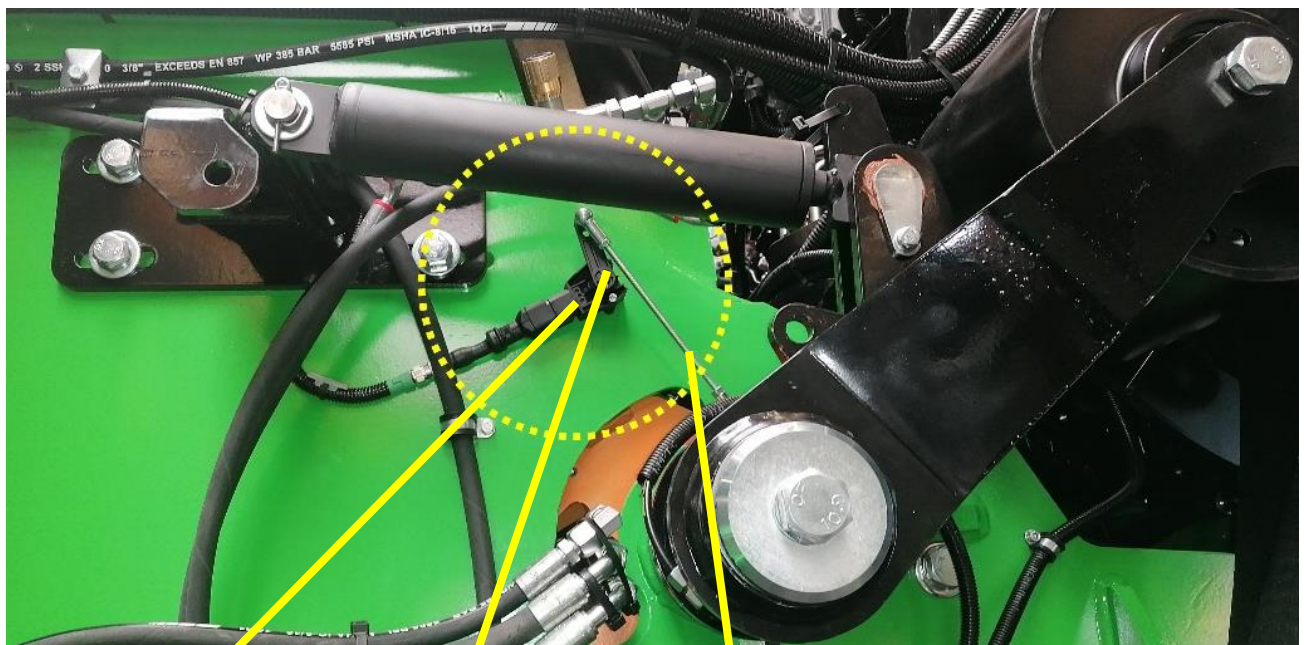

Angle sensor

Actuating lever

Threaded rod

7.8 Fault indications at the control

WARNING



Danger of injury due to improper disposal of fault indication

Improper disposal of fault indication can cause serious personal injury and property damage.

- Perform all maintenance work when the machine is stopped only.
- The main battery switch must be turned "OFF".
- No persons must stay on the endless floor conveyor or within the discharge area of the EP 5500 Shark!

Warning signals

| Fault / malfunction | Possible reason | Possible defect | Remedy |
|--------------------------------|-------------------------|--------------------|---------------------------------------|
| Indication „Motor hot“ | Cooler clogged, grating | | To be cleaned |
| | | Temperature sensor | Contact the client phone service |
| Indication „Battery no charge“ | Generator V-belt | | Check, v-belt generator, To strain |
| | | V-belt | Replace the V-belt |
| | | Electric generator | Contact the client phone service |
| Indication „Fuel empty“ | Fuel almost empty | | Refill |
| | | Fuel giver | Contact the client phone service |

Emergency stop signals

| Fault / malfunction | Possible reason | Possible defect | Remedy |
|--|--|--------------------|--|
| Indication „Overheating“ | Cooler polluted | | Clean it using a broom |
| | | Temperature sensor | Contact the client phone service |
| | | Cooler | See indication „Cooling water“ |
| Indication „Lack of oil“ | Motor oil level too low | | See motor manual. Contact the client phone service |
| Indication „Cooling water“ | Cooling water level too low | | Refill cooling water, check both cooling water hose and cooler for leakages and replace it, if necessary |
| | | Sensor | Contact the client phone service |
| Indication „Air filter“ | Preliminary filter clogged (mushroom type) | | Clean it using a brush and compressor air |
| | Air filter strongly polluted | Replace | Need to be cleaned, beat the air filter cartridges out or clean them otherwise |
| | | Pick-up | Contact the client phone service |
| Indication „Overheating “ Hydraulic oil | Oil filter polluted | Pick-up | Clean the oil cooler with compressed air |
| Indication „Hydraulic oil level to low “ | Hydraulic oil level too low | Pick-up | Refill hydraulic oil |

7.9 Fault finding table

| Fault / malfunction | Possible reason | Remedy |
|---|---|--|
| Draw-in roller or endless floor cannot be deactivated and com to Stop under low load or start running in reverse sense | Motor hot | Cooler strongly contaminated (needs to be cleaned) |
| | Low r.p.m. level set too low | Transmitter defect (to be replaced) |
| | | (Contact the client phone service) correct the adjustments |
| | Material jammed up (endless floor, draw-in roller, discharge belt) | (Caution!: unit must be in „OFF“ condition, check and remove jammed up material, if necessary) |
| | Hydraulic oil filter contaminated (oil motors come to Stop at low load) | Replace filter |
| | Respective pressure sensor defectively | Check, (Contact the client phone service) replace |
| | Control block defective (doesn't switch off) | To check it, switch the valves above the control block manually. If there is no reaction, the control block must be replaced (Contact the client phone service). |
| Oil motor defective (endless floor, draw-in roller, discharge come to Stop at low load) | Replace the oil motor. Check the hydraulic pressure. | |

| Fault / malfunction | Possible reason | Remedy |
|---|---|--|
| Low r.p.m. protection doesn't respond or pilot lamp shows light constantly | Low r.p.m. protection not properly set | (Contact the client phone service) adjust the low r.p.m. protection |
| Rotor bearings get hot | Dirt between rotor face and unit side wall or bearing defective, bearing defect, no lubrication | Check the rotor cleaner plates front-side, clean the spaces in-between or replace the cleaner plates, check the bearing and replace it, if necessary |
| Rotor doesn't turn | Power belts defective | Check and replace, if necessary (set by set) |
| | Coupling doesn't engage | See malfunction "Coupling engages" |
| | Rotor frozen up (winter) | Warm it up in a warm room |
| Coupling doesn't engage | Throttle valve misadjusted | (Contact the client phone service)) check and correct the adjustments, if necessary |
| | Solenoid valve defective Solenoid defective | (Contact the client phone service)) check and replace, if necessary |
| | Control unit defective | (Contact the client phone service) replace |

| Fault / malfunction | Possible reason | Remedy |
|--|---|--|
| The discharge belt stops, moves backwards or permanently changes its movement direction | Discharge belt jammed | Check the discharge conveyor for foreign debris, remove the foreign debris Contact the client phone service |
| | Pressure sensor defect | Contact the client phone service |
| Endless floor moves heavily or comes to stop | Cleaning worm clogged | Needs to be cleaned |
| | Endless floor clogged | Needs to be cleaned |
| Radio control doesn't work. Motor stops | Operator is in the radio shadow Remote control not charged (i.e. accumulator empty) | Change operator position Check, if necessary, recharge accumulators |
| Machine vibrates strongly | Flyweight in the rotor | Check if the flails are wearing out and check if they are complete. Replace flails, if necessary |
| Rotor produces loud noises | Flails not properly mounted | Check, correct and set straight, if necessary (see Chapter 7.7.1: Replacement of flails) |
| | Counter blades warped | Check and repair, if necessary |
| | Machine stands in extremely uneven position | Always make sure the machine is levelled horizontally |
| Motor does not reach full r.p.m. or runs sputtering | Fuel filter clogged | Clean the fuel filter, replace it, if necessary |
| | | E Pump defective. Safeguard |
| | No fuel | Refill fuel |
| | Ad Blue Feed faulty | AdBlue® Check system AdBlue® Replace Filter Obtain help from manufacturer's service department |

8.0 MAINTENANCE

WARNING



Danger of injury due to improper maintenance

- Perform all maintenance work on the EP 5500 Shark when the motor is stopped only.
- Make sure that the machine cannot be started by unauthorized persons!
- The main battery switch must be turned "OFF".
- No persons must stay on the endless floor or in the discharge area of the EP 5500 Shark with running motor!

While on duty, the EP 5500 Shark is exposed to strong mechanic strain and to strong production of dust. Moving parts of the unit must be serviced at short intervals, therefore. Regular servicing improves and significantly extends the EP 5500 Shark operating ability.

All greasing points are marked red. Press such a quantity of grease in till it emanates from the bearings to be greased. Thereby, the contaminated and used grease is pressed out of the bearing point together with the condensed water accrued there (Chapter 8.8, Grease types).

Timely replacement of worn parts maintains the EP 5500 Shark readiness for operation and contributes significantly to maintain its operational safety.

After the first 10 service hours, check all screws and bolts for tightness and from that point on check them each day and retighten them, if necessary.

The maintenance intervals indicated are based on a daily one-shift operation of the EP 5500 Shark.

Information in regard to fuel and cooling agent can be learned from a separate instruction manual issued by the motor producer.

NOTICE



For the maintenance of the drive motor is the separate operating instructions for the engine manufacturer's instructions.

This must be performed by an authorized service center.

Details for the lubrication can be found in the separate operating instructions of the manufacturer.

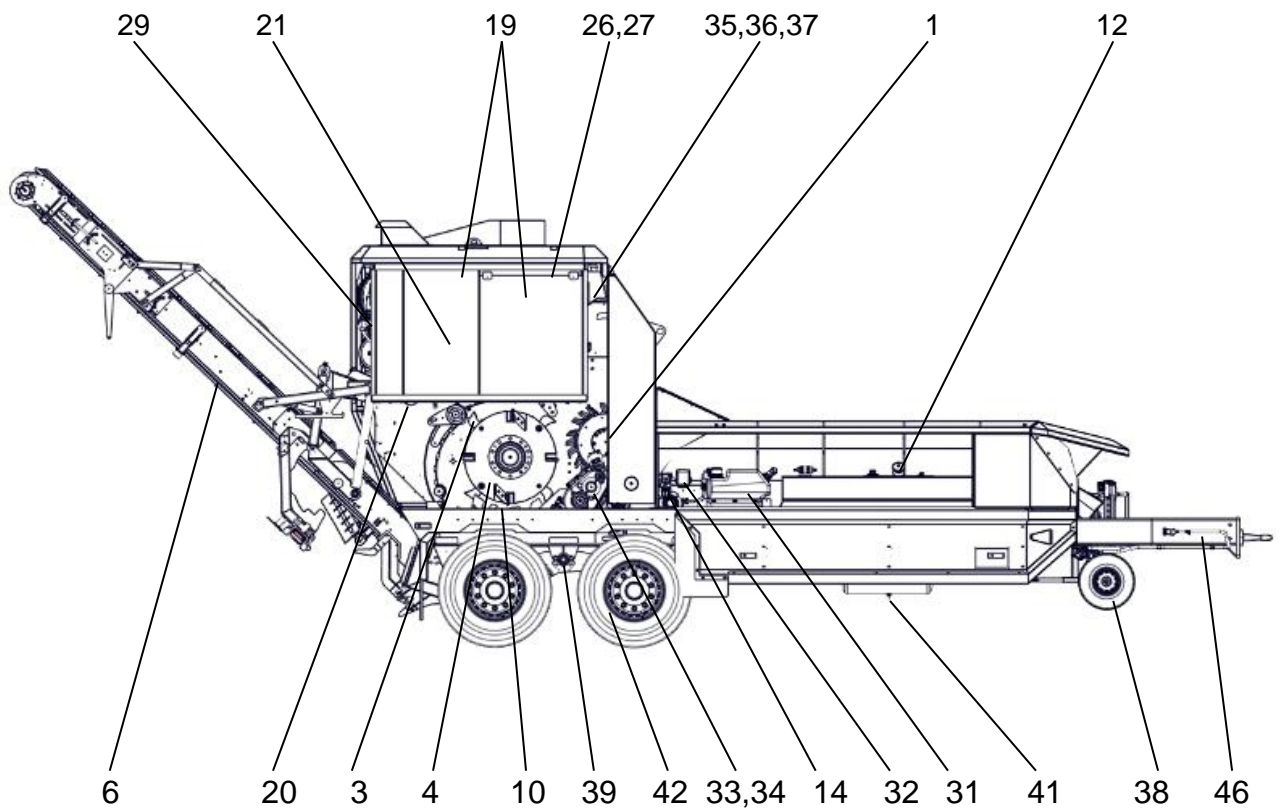

Illustration 8.1

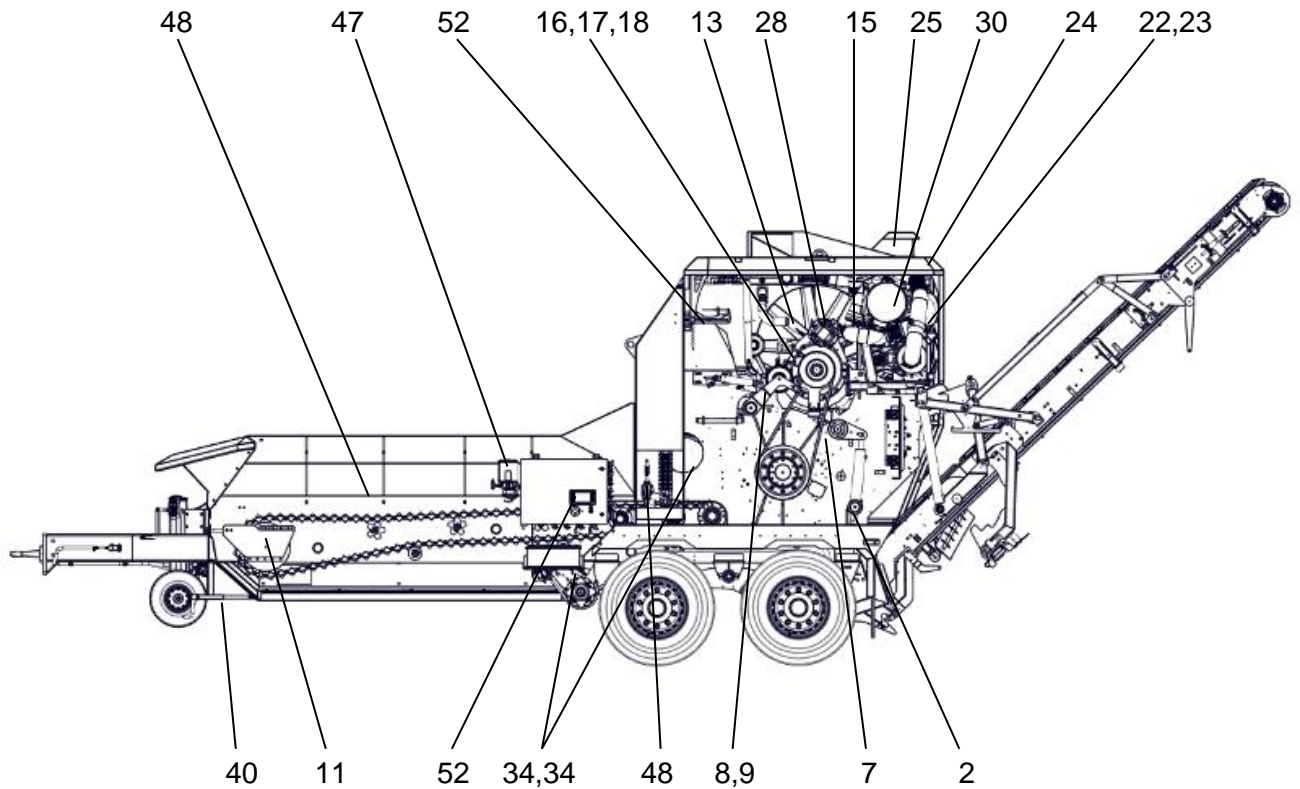

Illustration 8.2

8.1 Lubrication plan and other maintenance works (Illustrations 8.1 and 8.2)

| No | Maintenance work | Maintenance intervals in operating hours | | | | | Remark |
|----------------------|---|--|--|-----------|-------------|--------------|---|
| | | 10 h / daily | 50 h / weekly (100 h first service) | All 500 h | All 2.000 h | If necessary | |
| Basic machine | | | | | | | |
| 1 | Lubricate in-feed-roller bearing | X | | | | | Roller bearing grease, grease gun |
| 2 | Lubricate cylinder holder of shredding flap left and right | | X | | | | Roller bearing grease, grease gun |
| 3 | Check tools for wear, heavily worn flails must be replaced in sets | X | | | | | Striking weight, Hydraulic axle extractor |
| 4 | Check rotor, if necessary renew scraper and cutting edges | X | | | | | |
| 5 | Check the screws for a tight fit | X | | | | X | |
| 6 | Check the rubber belt of the discharge conveyor for damage and correct run | X | | | | | |
| 7 | Check main drive belt (power band), replace in pairs if damaged | X | | | | | |
| 8 | Check the belt tension; when the rotor is engaged, the tensioning cylinder must not be fully extended. If this is not the case, the tensioning cylinder must be moved forward | X | | | | | |
| 9 | Check the angle sensor, in the disengaged position the lever position is at 11 o'clock | | X | | | | See Illustration 7.22 |
| 10 | Check rake / basket, replace that by heavy wear | | X | | | | |
| 11 | Check endless floor tension; tighten evenly on left and right. The sagging of endless floor may be max. 5 cm | | X | | | | Once the stop has been reached, the rolling floor can be shortened by removing individual links |

| No | Maintenance work | Maintenance intervals in operating hours | | | | | Remark |
|--------------------|---|--|--|-----------|-------------|--------------|---|
| | | 10 h / daily | 50 h / weekly (100 h first service) | All 500 h | All 2.000 h | If necessary | |
| Fuel system | | | | | | | |
| 12 | Refill with fuel | X | | | | X | |
| 13 | Change fuel filter | | | X | X | | |
| 14 | Water separator – change filter | | | X | | | |
| Engine | | | | | | | |
| 15 | Clean the engine compartment | X | | | | X | Compressed air |
| 16 | Check oil level, top up engine oil if necessary | X | | | | | Use engine oil according to the instructions of the engine manufacturer |
| 17 | Oil change with oil filter change on the engine | | | X | | | Observe the instructions of the engine manufacturer |
| 18 | Check hydraulic drive (power take-off) oil level | | | X | | | |
| 19 | Radiator and oil cooler: Visual inspection, if necessary, remove external contamination | X | | | | X | Hand broom, Compressed air |
| 20 | Drain the condensation water in the intercooler | X | | | | | |
| 21 | V-belt fan, V-belt alternator - check tension, replace if necessary | | X | | | | |
| 22 | Replace the air filter and fuse cartridge | | | X | | X | |
| 23 | Check air filter for cleanliness, clean as required (blow out), replace if necessary | X | | | | X | Compressed air |
| 24 | Prefilter: Visual inspection, clean if dirty | X | | | | X | Hand broom, Compressed air |
| 25 | Intake grille on bonnet: visual inspection, clean if dirty | X | | | | X | Hand broom, Compressed air |
| 26 | Check coolant level, top up if necessary | X | | | | | |
| 27 | Check antifreeze | | | X | | X | Antifreeze as specified by the engine manufacturer |
| 28 | Adjust valves | | | X | | | Every 1,000 hours - every second 500 hour service |

| No | Maintenance work | Maintenance intervals in operating hours | | | | | Remark |
|-------------------------|--|--|--|-----------|-------------|--------------|-----------------------------------|
| | | 10 h / daily | 50 h / weekly (100 h first service) | All 500 h | All 2.000 h | If necessary | |
| 29 | Change the air dryer cartridge | | | | X | | |
| 30 | Clean the particle filter | | | | | X | Status can be checked via control |
| SCR-system | | | | | | | |
| 31 | Check level Adblue®, top up if necessary (only below 75%) | X | | | | | |
| 32 | Change Adblue® filter | | | X | | | |
| Gears | | | | | | | |
| 33 | Check oil level, top up if necessary | | X | | | | |
| 34 | Oil change | | | | X | X | Control plug |
| Hydraulic system | | | | | | | |
| 35 | Clean (blow out) the bleed port of hydraulic oil | | X | X | | | Compressed air |
| 36 | Change hydraulic oil | | | | X | | |
| 37 | Change hydraulic filter cartridge and return filter | | | X | | | |
| Chassis | | | | | | | |
| 38 | Lubricate support foot bearings left and right | | X | | | | Roller bearing grease, grease gun |
| 39 | Lubricate springs and brake levers on axles | | | X | | | Roller bearing grease, grease gun |
| 40 | Lubricate crank for parking brake | | | X | | | Roller bearing grease, grease gun |
| 41 | Drain the condensation water from the brake air tank at the drainage valve | | | | | X | |
| 42 | In the case of spring clips, check the screws and tighten if necessary | | | X | | | |
| 43 | Drawbar eye: visual inspection, check correct condition of fixing screws | X | | | | X | before using public roads |
| 44 | Tires: check the tire pressure (8.5 bar), check profile and wheel nuts | X | | | | X | before using public roads |
| 45 | Check the lighting for function | X | | | | X | before using public roads |
| 46 | Check brakes | X | | | | X | before using public roads |

| No | Maintenance work | Maintenance intervals in operating hours | | | | | Remark |
|-----------------------------|--|--|--|-----------|-------------|--------------|---|
| | | 10 h / daily | 50 h / weekly (100 h first service) | All 500 h | All 2.000 h | If necessary | |
| Central lubrication | | | | | | | |
| 47 | Fill the grease reservoir from the central lubrication system | | X | | | X | Use EP 2 grease as specified on the container |
| 48 | Machine without central lubrication lubricate on lubrication strips | X | | | | | Roller bearing grease, grease gun |
| Radio remote control | | | | | | | |
| 49 | Check radio control for function | | X | | | | |
| 50 | Check battery capacity, recharge if necessary | X | | | | X | |
| 51 | Replace the battery | | | | | X | |
| Safety devices | | | | | | | |
| 52 | Check all safety devices according to operating instructions such as emergency stop, hood safety, etc. for functionality | X | | | | X | |

8.2 Lubricant table EP 5500 Shark

| Component | Operational materials | Filling quantity | Manufacturer designation | Viscosity mm ² /s (40°C) | Specification |
|-------------------------------|-----------------------|------------------|---|-------------------------------------|---------------|
| Engine MAN D2676 LE 139 | *Diesel fuel | 500 l | Diesel fuel | 2 - 4,5 | DIN EN 590 |
| | *Biodiesel | 500 l | Bio-Diesel RME | 4 | DIN EN 14214 |
| | Motor oil | 42 l | 5W-30 | 67 | MAN 3677 |
| Cooler | Antifreeze | 82 l | Antifreeze X12 Plus -37° | 20-30 at 20°C | MAN 324 SNF |
| Hydraulic | Hydraulic oil | 330 l | Meguin Hydrauliköl HVLPD 46 | 22-46 | DIN 51524 |
| In-feed roller gears | Gear oil | 1,5 l | Megol Hypoid - Getriebeöl GL5 SAE 85W-140 | 320 | DIN 51517 |
| Endless floor gears | Gear oil | 4,3 l | MEGOL Getriebeöl CLP 320 | 320 | DIN 51517 |
| Wheel drive gears | Gear oil I | 3,5 l | Meguin Getriebeöl CLP 320 | 320 | DIN 51517 |
| Discharge conveyor gears | Gear oil | 0,75 l | Meguin Getriebeöl CLP 320 | 320 | DIN 51517 |
| Magnetic roller gears | Gear oil | 0,5 | Meguin Getriebeöl CLP 320 | 320 | DIN 51517 |
| SCR-System | AdBlue® | 80 l | AdBlue® | Not determined | DIN 70070 |
| lubrication | lubricating grease | 3 kg | Meguin Langzeitfett C2LP | 20,5 | DIN 51502 |

NOTICE



Extinguishing the warranty claims due to non-approved fuels!

* If the engine is operated with fuel in deviation from the specifications EN 590 and EN 14214, our liability for defects is limited.

- Use the authorized fuels use only

8.3 Replacement of the trailer coupling ring

Replace the trailer coupling ring when that has become warped. When changing it, replace the spring lock washer, too. Use 10.9 screws with torque.

8.4 Replacement of the brake lining

If the brake linings have reached their wear limits, must be replaced in an authorized workshop.

8.5 Changing of the wheels

DANGER



Danger of rolling away the EP 5500 Shark

When the EP 5500 Shark unintentionally set in motion, it can result serious or even fatal injuries.

- Secure the EP 5500 Shark against rolling away with wheel wedges.
- To change the wheels, the EP 5500 Shark can be lifted at the axis.
- Tighten wheels with torque.



8.6 Hydraulic oil change

NOTICE

Extinguishing the warranty claims due to non-approved operating supplies!

When using non-approved operating supplies will extinguish the warranty claims.



- Use the authorized fuels use only.
- Make sure to comply with the instructions of the respective hydraulic oil producer when replacing mineral oil by bio oil or vice versa.
- Before replacement of the complete hydraulic oil, please contact our service department. (Chapter 8.13, Service addresses)

For maintenance works or service routines to be performed at the motor and for refilling of hydraulic oil, use the hand pump to open the motor hood. (Chapter 6.3, Commissioning).

After 5 - 10 service hours check all screwed connections of the hydraulic system for tightness and retighten them, if necessary.

Make sure to comply with the instructions of the respective hydraulic oil producer when replacing mineral oil by bio oil or vice versa.

8.7 Recommended hydraulic oil types

| Producer | Oil type HLP/Type name | Viscosity in mm ² /s at 40°C |
|----------|-------------------------------|---|
| ARAL | Vitam GF 46 | 40-50 |
| ARAL | Vitam GF 68 | 60-80 |
| AVIA | Fluid RSL 46 M | 40-50 |
| AVIA | Fluid ZAD 46 M | 40-50 |
| AVIA | Fluid RSL 68 M | 60-80 |
| BP | Energol HLP HM46 | 40-50 |
| BP | Bartan 46 | 40-50 |
| BP | Bartan SHF-S46 | 40-50 |
| BP | Energol HLP HM68 | 60-80 |
| BP | Bartan 68 | 60-80 |
| CASTROL | HYSTIN AWS 46 | 40-50 |
| CASTROL | Paradene 46 AW | 40-50 |
| CASTROL | HYSTIN AWS 68 | 60-80 |
| CASTROL | Paradene 68 AW | 60-80 |
| CHEVRON | Hydraulic Oil AW 46 | 40-50 |
| CHEVRON | Hydraulic Oil AW 68 | 60-80 |
| ESSO | NUTO H 46 | 40-50 |
| ESSO | Hydraulic Oil HLP 46 | 40-50 |
| ESSO | NUTO H 68 | 60-80 |
| ESSO | Hydraulic Oil HLP 68 | 60-80 |
| FUCHS | RENOLIN MR 15 VG 46 | 40-50 |
| FUCHS | RENOLIN B 15 VG 46 | 40-50 |
| FUCHS | RENOLIN ZAF 46 B | 40-50 |
| FUCHS | RENOLIN MR 20 VG 68 | 60-80 |
| FUCHS | RENOLIN MR 68 MC | 60-80 |
| FUCHS | RENOLIN B 20 VG 68 | 60-80 |
| FUCHS | RENOLIN ZAF 68 B | 60-80 |
| MOBIL | Mobil DTE 25 | 40-50 |
| MOBIL | Mobil DTE Excel 46 | 40-50 |
| MOBIL | Mobil DTE 26 | 60-80 |
| MOBIL | Mobil DTE Excel 68 | 60-80 |
| SHELL | Shell TELLUS 46 | 40-50 |
| SHELL | Shell TELLUS DO46 | 40-50 |
| SHELL | Shell TELLUS S 46 | 40-50 |
| SHELL | Shell TELLUS 68 | 60-80 |
| SHELL | Shell TELLUS DO 68 | 60-80 |
| SHELL | Shell TELLUS S 68 | 60-80 |
| MEQUIN | Meguin HVLDP46 | 22-46 |
| MEQUIN | Meguin HVLP68 | 68 |
| MOTOREX | Focus QTM SAE 10W/40 | |
| MOTOREX | Gearoil Universal SAE 85W/140 | |
| MOTOREX | Gear Compound Plus | |
| MOTOREX | Corex HV 68 | |
| MOTOREX | Corex HVLP-D 46 | |

Bio oil types:

Based on the characteristics and the releases on hand and issued by the suppliers of the hydraulic system components integrated in the shredding unit, it is recommended to use "HEE" hydraulic liquid types only (synthetic ester). Oils of this type comply with the standards according to DIN 51524 T2 or T3.

Producer / Type name

| | |
|-------------------|---------------------|
| Aral | EHT 46 Vitam |
| Agip | Agip Arnica S 46 |
| Avia | Avia Synthofluid 46 |
| BP | Biohyd 46 SE |
| DEA | Econa E 46 |
| ELF | Hydrelf Bio 46 |
| ESSO | EGL 45947 |
| Fuchs | Plantosyn 3268 E 00 |
| Oest | Bio Synth. HYD 46 |
| PANOLIN | HLP Synth. 46 |
| SHELL | Naturelle HF-E 46 |
| TOTAL | Equivis Bio 46 |
| WENZEL + WEIDMANN | Ukabiol HE 46 |
| WESTFALEN AG | Bio Forbex E 46 |
| MOTOREX | DEKOSYNT HEES 46 |

8.7.1 Oil filling amounts for the gears

| | | |
|--------------------|--------|--|
| Infeed roller | 1,5 l | Megol Hypoid-Gear oil GL5 SAE 85W-140 |
| Endless floor | 3.5 l | Mequin Gear oil CLP 320 |
| Wheel drive | 3.5 l | Mequin Gear oil CLP 320 |
| Discharge conveyor | 0.75 l | Mequin Gear oil CLP 320 |
| Magnetic separator | 0,5 l | Mequin Gear oil CLP 320 |

Gear oils: It should be used oils with viscosity 320 mm²/s at 40°C only.

8.8 Grease types to be applied

The roller bearing grease types should be used basically, which the application of temperature ranges are from - 20 °C up to + 135 °C only.

The NLGI no. for penetration is: "2"(no liquid grease).

Do not use the liquid grease for central lubrication system.

Producer type

Autol Top 2000

Meguin Langzeitfett C2LP

8.9. Engine oil change

Drain hose

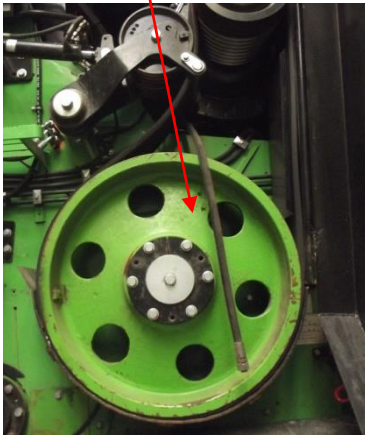

For industrial diesel engines are used the engine oils, which one are authorized to manufacture standard.

The choice of suitable engine oil is based on planned oil operating time, the used fuel quality and the climatic conditions on site.

Basically the specified from publication "supplies for MAN industrial and marine diesel engines" approved engine oils according to MAN works standard M 3677 can be used.

Drain the engine oil when the engine is at operating temperature.

- Hang out the drain hose under oil pan;
- Use a vessel with sufficient capacity under the drain hose;
- Allow engine oil to drain completely.
- Then close the drain hose and add a sufficient amount of suitable engine oil up to the max. Mark and then check the engine oil level.

NOTICE

There is the risk of damage to property caused by oil overflow

When filling of engine oil over the max. - Marking, may occur the engine damage.

- Never fill in more than the quantity of oil specified.

Filling amount (with filter)

42 l

8.10 Refill coolant

CAUTION

Risk of burns from hot surface or liquid

- When opening the hot cooling system can cause hot steam escape.
- Always wear protective clothing and gloves when working near hot components
- Prior to working to ensure that all components have cooled to ambient temperature.

- Solve the radiator cap and drain off excess pressure.
- Refill coolant up to the top of the surge tank.
- Close radiator cap securely.



Cooler cap



| Producer | Manufacturer's designation | Viscosity in mm ² /s at 20°C |
|----------------|----------------------------|---|
| ARAL | Antifreeze Extra | 20-30 |
| Filling amount | | 82 l |

8.11 Proper function of the emission reduction system

8.11.1 AdBlue® / DEF quality

AdBlue® is a high purity, synthetically manufactured 32.5% carbamide-water solution, as clear as water. The high-quality solution reduced in the SCR technology diesel-powered machine toxic nitrogen oxides in the exhaust gas to form water vapor and elemental nitrogen.

The high purity and consistent quality are guaranteed only by using AdBlue® according to DIN 70070.

DEF - Diesel Exhaust Fluid (= AdBlue®/AUS32) ISO22241

Store AdBlue® / DEF:

If AdBlue® cooled below -11°C , it freezes.

AdBlue® is stored at the original sealed containers 12 months under conditions listed below:

- Storage temperature $> -10^{\circ}\text{C}$ respectively $< 25^{\circ}\text{C}$;
- Protection from direct sunlight;
- Closed containers.

8.11.2 Refill AdBlue® / DEF tank

AdBlue® is not an additive, but is located on machines with SCR technology in a separate tank.

The AdBlue® / DEF tank is located on the right side of the machine next to the diesel tank.

The tank volume of AdBlue® / DEF tank is 80 liters.

Contaminated AdBlue® / DEF causes damage to the overall system:

- Ensure on a clean filling.
- Use AdBlue® in accordance with ISO 22241 or DIN 70070 only.
- Keep AdBlue® / DEF tank and AdBlue® / DEF-pipe system free of detergents and fuel.
- Each diesel refuelling the DEF supply should be too complemented.
- The DEF consumption is dependent on the power take-off of the engine.

AdBlue® Tank



8.11.3 EU Stage V - Emission Requirements

In the EP 5500 Shark is a diesel engine installed, which must meet the requirements of EU Stage V. Fulfilment of these requirements requires the use of suitable liquids. Information about the appropriate fuels, lubricants and coolants are taken from the publication "supplies for MAN industrial and marine diesel engines". The use of appropriate fuels, lubricants and coolants influences the ability of the engine, its nominal capacity to produce fuel in fuel consumption and to comply with emission regulations.

NOTICE

JP8 diesel fuel and biodiesel can damage the engine and the after treatment system.

- Use the AdBlue® in accordance with ISO 22241 or DIN 70070 only.
- For the operation of MAN diesel engines, diesel fuel is suitable to the following standards:

European Standard

EN590

Germany

DIN EN 590

USA

ASTM D 975a

UK

BS 2869 Part 1 Class A 1

8.13 Service addresses

J. Willibald GmbH

Recyclingtechnik
Bahnhofstraße 6
D- 88639 Wald-Sentehart

Tel.: +49 (0) 7578 / 1890
Fax: +49 (0) 7578 / 189150
E-Mail: info@willibald-gmbh.de
www.willibald-gmbh.de

Willibald Service & Instandsetzungszentrum

Im Wolfgraben 5
D-36414 Unterbreizbach

Tel.: +49 (0) 3 69 62 / 5 14 10
Fax: +49 (0) 3 69 62 / 5 14 18
E-Mail: info.ubba@willibald-gmbh.de

Raiffeisen Agil Leese eG

Oehmer Feld
31633 Leese

Tel.: +49 (0) 5761 92110
Fax: +49 (0) 5761 9211-66
E-Mail: info@rwg-leese.de

9.0 REPAIR

WARNING



Danger of injury due to improper repair

Improper repair can cause serious personal injury and property damage.

- Perform all maintenance work when the machine is stopped only.
- The main battery switch must be turned "OFF".
- No persons must stay on the endless floor conveyor or within the discharge area of the EP 5500 Shark!

NOTICE



Property damage caused by incorrect repair

In case of inobservance of the above items we deny assuming any claims for guarantee services and refuse to assume any liabilities in the event of personal injury and/or damage to property.

- Make sure all working cycles are strictly complied with in the prescribed order. Unauthorized manipulations of devices prohibited.
- No other than as the fuels and process materials listed herein must be used.
- Apply original spare parts only, do not use any parts other than those listed in the spare parts list.
- Work on the t-Wision can be performed by a qualified electrician only.
- All maintenance works beyond those described in Chapters 7.7 and 8.0 must be cleared and discussed with the competent service agency first (Chapter 8.13 Service addresses).

10.0 PUTTING THE MACHINE OUT OF ACTION

The decommissioning and recommissioning of the EP 5500 Shark may be performed by trained personnel only.

WARNING



Danger of injury due to improper works

Improper works can cause serious personal injury and property damage.

- Make sure that the motor cannot be started by unauthorized persons!
- The main battery switch must be turned "OFF".
- All bearings must be greased after washing the machine.
- Radiator (antifreeze control).
- See the motor operation manual.

11.0 CLEANING AND CARING

Regular care helps maintain the value of the machine. Clean the machine on a designated wash area only. Dispose of empty containers and used cleaning materials environmentally friendly manner.

11.1 Indoor cleaning

11.1.1 Motor compartment

Highly flammable materials - diesel fuel, oils and fats

WARNING



Fire hazard due to highly flammable materials!

Dirt accumulations in the motor compartment can cause a fire hazard and severe to fatal injuries.

Pieces of wood and wood dust are inflammable!

Fuel and hydraulic fluid are inflammable!

- Cleaning is permitted with the switched off motor only.
- Do not use the flammable cleaning agents.
- Clean the motor compartment with compressed air only.



NOTICE



By cleaning with compressed air increased amounts of dust is produced and the eyes are at risk.

Use the safety goggles to protect the eyes from flying small parts.

11.2 Outdoor cleaning

NOTICE



Danger of property damage due to incorrect handling with high pressure cleaners

Move the water jet during the cleaning, when cleaning with high pressure cleaner. To avoid damage, do not focus the water jet directly onto electrical components and electrical connectors.

12.0 DISPOSAL



CAUTION

Environmental hazard by incorrect handling

At an incorrect handling of environmentally hazardous substances, especially at a incorrect disposal, significant damage can occur to the environment.

- Observe always the below prescribed information.
- When accidentally get environmentally hazardous substances reach into the environment, take immediate and appropriate action. When in doubt, you must inform the responsible local authority of the loss.

The following environmentally hazardous substances are used:

Lubricants

Lubricants such as greases and oils contain toxic and environmentally hazardous substances. They must not be released into the environment. Disposal must be made by a waste disposal contractor.

Diesel fuel

Diesel fuel contains toxic and environmentally hazardous substances. They must not be released into the environment. Disposal must be made by a waste disposal contractor.

Coolant

Coolant contains toxic and environmentally hazardous substances. They must not be released into the environment. Disposal must be made by a waste disposal contractor.

AdBlue®

AdBlue® can be exploited by microbes and is therefore very easily degradable. This means that AdBlue® presents only very minimal risk to the environment. Due to its degradability, small quantities of AdBlue® can be emptied into the sewerage system when diluted with a copious quantity of water.

Large quantities of AdBlue® must not enter the environment. The disposal must be carried out by an appropriate qualified disposal company.

Hydraulic oil

Hydraulic oils contain toxic and environmentally hazardous substances. Hydraulic oils must not enter drains. Avoid the intrusion into surface and groundwater as well as ground. Make sure that used oils are collected!

When leakage of absorbent material, collect this and dispose at suitable refuse site. Do not use water.

Old parts and wear parts

Old parts, as well as wear parts are subject to the mandatory inclusion in the current value of waste disposal.

13.0 Instructions for ordering of spare parts

Use the exclusive original WILLIBALD - spare parts only.

Our approved original spare parts are checked by us and thus have the suitable conditions for the use of the machine only.

For these parts, the reliability and safety has been established. For other products, we cannot do this, despite ongoing market monitoring to judge, and cannot vouch for it.

WARNING



Danger of injury by improper replacement parts

Incorrect or faulty spare parts, in particular wear parts can cause damage, malfunction or failure and impair safety.

- Use Willibald-original spare and wear parts only.

NOTICE

Orders for spare parts must be provided to and placed with the competent dealer and must contain the following particulars:

1. Machine type and machine no.
2. Part number and description of the required individual part.
3. Quantity of the desired spare parts
4. Indication of shipment address and postal code.
5. Desired way of shipment

The vehicle identification plate is attached to draw bar, right in the direction of travel of the machine.



Information on hydraulic components:

In case hydraulic components of the machine must be repaired we recommend and advise to replace complete components only.









The illustrations shown in the spare part list will not always correspond exactly to the original spare parts, as parts may have changed due to technical advancement after completion of the list.









When ordering parts, the part number of which cannot be determined safely, a sample piece must be provided to WILLIBALD to avoid delivery of wrong parts.

If no demand to return said samples is made, these will be scrapped.

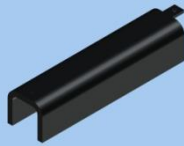
Timely repair of the machine saves time and money!

14.0 Inventory list

| N | Designation | Picture | Willibald-No. | Quantity |
|---|--|--|---------------|----------|
| 1 | Fire extinguisher |  | 660-81-012 | 1 |
| 2 | Protective film for fire extinguishers |  | 660-81-013 | 1 |
| 3 | Wheel wedges |  | 053-01-001 | 2 |
| 4 | Ladder |  | 665-80-028 | 1 |
| 5 | Radio remote control |  | 913-90-050 | 1 |
| 6 | Charging holder radio |  | 913-90-035 | 1 |
| 7 | Securing rod, coupling securing |  | 665-80-007 | 1 |
| 8 | Bolt, coupling securing |  | 660-30-010 | 2 |

| N | Designation | Picture | Willibald-No. | Quantity |
|----|--|--|---------------|----------|
| 9 | Striking weight, flail shaft extractor |  | 423-80-018 | 1 |
| 10 | Auxiliary shaft, Hydraulic flail shaft extractor |  | 660-81-027 | 1 |
| 11 | Screw, Hydraulic flail shaft extractor |  | 660-80-011 | 1 |
| 12 | U-Profile, Hydraulic flail shaft extractor |  | 665-80-006 | 3 |
| 13 | Lever for the hand pump |  | 665-22-501 | 1 |
| 14 | Bolt, infeed roller securing |  | 665-40-100 | 1 |
| 15 | Support rod, discharge conveyor securing |  | 665-50-398 | 2 |
| 16 | Bolt, discharge conveyor securing |  | 660-30-010 | 4 |
| 17 | Bolt, discharge conveyor securing |  | 665-50-294 | 2 |

16.0 General terms and conditions J. Willibald GmbH Recyclingtechnik, 88639 Wald-Sentehart

For all business transactions such as ordering spare parts, etc., our following general terms and conditions apply in the current version without exception.

For use towards:

1. A person acting in the exercise of their commercial or independent vocational activity in the conclusion of the contract (entrepreneur);
2. Corporate body under public law or a public separate estate.

I. General

1. All deliveries and services are performed based on these terms as well as any special contractual agreements. Different purchasing terms of the ordered do not become part of the contract even by acceptance of the order.

A contract comes into force - unless agreed otherwise - with the written order confirmation or sending of the supplier's delivery note.

2. The supplier reserves right of ownership and copyrights to samples, quotes, drawings and similar information of a physical and immaterial kind - also in electronic form; they may not be made accessible to third parties. The supplier undertakes only to make information and documents marked by the orderer as confidential accessible to third parties with the orderer's express permission.

II. Price and payment

1. Unless agreed otherwise, the prices apply ex-factory including loading in the factory but excluding packing, transport and unloading. The respective legally applicable value-added tax will be added to the prices.

2. Unless agreed otherwise, payment must be made to the account of the supplier without any deductions and in particular **for machines**: 1/3 advance payment upon receipt of the order confirmation, 1/3 as soon as the orderer has been notified that the main components are ready for dispatch, the remaining amount within one month after transfer of risk as well as **in the case of spare and wearing parts** generally after 14 days net.

3. The orderer only has the right to withhold payments insofar as their counterclaims are undisputed and determined legally valid.

4. The order only has the right to settle against counterclaims from other legal relations insofar as they are undisputed or determined legally valid.

III. Delivery time, delivery delay

1. The delivery time is given by the agreements between the contract parties. Compliance therewith by the supplier assumes that all commercial and technical issues between the contract parties have been clarified and the orderer has fulfilled all obligations such as the provision of the necessary official certificates or approvals or the making of an advance payment. If this is not the case, the delivery time shall be extended accordingly. This does not apply insofar as the supplier is responsible for the delay.

2. Compliance with the delivery time is under reserve of correct and on-time self-delivery. The supplier shall announce foreseeable delays as soon as possible.

3. The delivery time is complied with when the object of delivery has left the supplier's factory or proclaimed ready for dispatch before its expiry. If acceptance is to be carried out, the acceptance date - except in the case of justified refusal of acceptance - is decisive, alternatively the announcement of readiness for dispatch.

4. If the dispatch or acceptance of the object of delivery is delayed for reasons for which the orderer is responsible, any costs incurred due to the delay will be charged to them beginning with the month after announcement of readiness for dispatch or acceptance.

5. If the non-compliance with the delivery time is due to force majeure or other events outside of the supplier's sphere of influence, the delivery time will be reasonably extended. The supplier will notify the orderer of the beginning and end of such circumstances as soon as possible.

6. The orderer can withdraw from the contract without notice if the entire service becomes impossible for the supplier prior to transfer of risk. The orderer can also withdraw from the contract if performance of part of the delivery for an order becomes impossible and they have a justified interest in rejection of the partial delivery. If this is not the case, the orderer must pay the contract price for the partial delivery. The same applies in case of inability to perform of the supplier. Section VII.2 applies in addition. If impossibility or inability to perform occurs during acceptance default or the orderer is solely or mainly responsible for these circumstances, they remain obliged to perform return service.

7. If the supplier gets into default and the orderer incurs damages as a result, the orderer is entitled to demand a default compensation sum. This shall be 0.5% for every full week of the delay but in total maximum 5% of the value of that part of the total delivery which cannot be used on time or according to the contract due to the delay.

If the orderer sets the supplier a reasonable period of grace for providing the service after the due delivery date - under consideration of the legal exceptions - and this period of grace is not complied with either, the orderer shall be entitled to withdraw from the contract within the scope of the legal provisions. They are obliged to declare at the supplier's demand within reasonable notice whether they will exercise their right of withdrawal.

Further rights from delivery default are determined exclusively in accordance with section V11.2 of these terms.

IV. Transfer of risk, acceptance

1. The risk is transferred to the orderer when the object of delivery has left the factory, even in the case of partial deliveries or if the supplier has accepted other services, e.g. dispatch costs or delivery and installation. If acceptance is to be carried out, this is decisive for the transfer of risk. It must be carried out immediately on the acceptance date or alternatively after announcement of the readiness for acceptance by the supplier. The orderer may not refuse acceptance in the case of an insignificant defect.

2. If dispatch or acceptance is delayed or fails due to circumstances for which the supplier is not responsible, the risk is transferred to the orderer from the day of announcement of readiness for dispatch or acceptance. The supplier is obliged to take out the insurances demanded by the orderer at the orderer's cost.

3. Partial deliveries are permitted insofar as they are reasonable for the orderer.

V. Retention of title

1. The supplier reserves the right of title to the object of delivery until receipt of all payments - also for any additional owed services - from the contract of delivery.

2. The supplier is entitled to insure the object of delivery against theft, breakage, fire, water and other damages on the orderer's account insofar as the orderer has not provenly taken out their own insurance.

3. The orderer may neither sell, pledge or transfer the object of delivery as security. They must notify the supplier immediately in the event of pledges and confiscation or other dispositions by third parties.

4. In the case of conduct of the orderer in breach of contract, especially payment default, the supplier is entitled to repossess the object of delivery after reminder and the orderer is obliged to hand it over.

5. The supplier can only demand handover of the object of delivery on grounds of retention of title if they have withdrawn from the contract.

VI. Claim for defects

For material and legal defects, the supplier is liable under exclusion of further claims - subject to section VII - as follows:

Material defects

1. All parts must be repaired or replaced defect-free at the supplier's discretion that are determined defective due to a circumstance prior to the transfer of risk. The determination of such defects must be reported to the supplier immediately in writing. Replaced parts become the property of the supplier.

2. In order for the supplier to perform all the repairs and replacement deliveries that appear necessary to them, the orderer must, in agreement with the supplier, give the supplier the necessary time and opportunity to do so; otherwise the supplier is released from their liability for the resulting consequences.

The orderer only has the right to eliminate the defect themselves or have it eliminated by third parties and demand reimbursement of the necessary expenses from the supplier in urgent cases of danger for operational safety or prevention of unreasonably extensive damages, whereby the supplier must be notified immediately.

3. The supplier will bear - insofar as the complaint transpires to be justified - the necessary expenses for the purpose of cure insofar as the supplier is not unreasonably burdened thereby. If the expenses are increased by the buyer moving the object of purchase to a different site than the place of fulfillment, resulting extra costs shall be paid by the buyer. The supplier also replaces the orderer's expenses within the scope of the right of recourse in the delivery chain with the sale of a newly manufactured object within the scope of their legal obligations.

4. The orderer has a right to withdraw from the contract within the law if the supplier - under consideration of the legal exceptions - allows a set reasonable period of grace for repair or replacement delivery due to a material defect to expire without fulfillment. In the case of an insignificant defect, the orderer only has the right to reduce the contract price. The right to reduce the contract price remains otherwise excluded.

5. Further rights are determined exclusively by section VII. 2 of these terms.

6. No liability will be accepted particularly in the following cases: Unsuitable or improper use, incorrect assembly or commissioning by the orderer or a third party, natural wear, improper or careless handling, incorrect maintenance, unsuitable operating media, defective construction work, unsuitable building ground, chemical, electrochemical or electrical influences - insofar as the supplier is not responsible.

7. If the orderer or a third party performs defective repairs, the supplier shall not be liable for the resulting consequences. The same applies in the absence of the supplier's prior consent for modifications made to the object of delivery.

Legal defects

8. If the use of the object of delivery leads to violation of domestic commercial protection rights or copyrights, the supplier shall generally procure on their own account the right for further use by the orderer or modify the object of delivery in such a way reasonable for the orderer that the violation of protection rights no longer exists.

If this is not possible under reasonable economic conditions and within a reasonable time, the orderer is entitled to withdraw from the contract. Under the cited preconditions, the supplier also has the right to withdraw from the contract.

In addition, the supplier will release the orderer from undisputed or legally determined rights of the owners of protective rights concerned.

9. The obligations of the supplier named in section VI. 8 are final for the event of violation of protection rights or copyrights subject to section VII.2.

They only exist when

- the orderer informs the supplier immediately of claimed violations of protection rights or copyrights,
- the orderer gives the supplier adequate support in the defense of claims or enables the supplier to carry out modification measures in accordance with section VI. 8,
- rights for all preventive measures including out-of-court settlements are reserved for the supplier,
- the legal defect is not based on an instruction of the orderer and
- the violation was not caused by the orderer modifying the object of delivery without authorization or using it in a way contrary to the contract.

VII. Liability of the supplier, exclusion of liability

1. If the orderer is unable to use the object of delivery in accordance with the contract due to culpable forborne or faulty suggestions or consultations on the part of the supplier before or after conclusion of contract or culpable violation of other contractual secondary obligations - especially instructions for operation and maintenance of the object of delivery, the rulings of sections VI and VII.2.

2. apply with exclusion of further rights of the orderer. The supplier is only liable for damages - for whatever legal reasons - not to the object of delivery itself

- a. in case of willful intent and gross negligence,
- b. in case of culpable injury to life, body and health,
- c. in case of defects that they have maliciously concealed,
- d. within the scope of a warranty pledge,
- e. in case of defects of the object of delivery insofar as they are liable for personal and property damages on privately used objects according to the product liability law.

In case of culpable violation of significant contract obligations, the supplier is also liable in case of negligence but limited to the contract-typical, reasonably foreseeable damage. Further rights are excluded.

VIII. Statute of limitations

All rights of the orderer - for whatever legal reason - come under the statute of limitations in 12 months or 1,000 operating hours (whichever occurs first) for new machines since delivery, assuming single-shift operation, for used machines, only the contractual agreement applies: This applies also for the statute of limitations of rights of recourse in the delivery chain in accordance with § 445b Par. 1 BGB (Civil Code) insofar as the last contract in the delivery chain is not a consumables purchase. The suspension of expiry from § 445b Par. 2 BGB remains unaffected. The legal periods apply for damage compensation claims in accordance with section VII. 2 a-c.

IX. Use of software

If the scope of supply includes software, the orderer is granted a non-exclusive right to use the delivered software including its documentations. It is handed over for use on the designated object of delivery. Use of the software on more than one system is forbidden.

The orderer may only copy, revise or translate the software or convert from the object code to the source code to the legally permitted extent (§§ 69 a ff. UrhG (Copyright Law)). The orderer is obliged not to remove manufacturer specifications - especially copyright notes - or to change them without the prior express permission of the supplier.

All other rights to the software and documentations including copies remain with the supplier or software supplier. Granting of sub-licenses is not permitted.

X. Applicable law, place of jurisdiction

1. The relevant law of the Federal Republic of Germany for the legal relation between domestic parties applies exclusively for all legal relations between the supplier and the orderer.

2. The place of jurisdiction is the court responsible at the supplier's headquarters. However, the supplier is entitled to institute legal proceedings at the headquarters of the orderer.