

Pos.	Teile-Nr. Part-Nr. Piece-Nr.	Quant.							Benennung	Description	Désignation	DIN	Maße Norm Dimens.
		80	90	100	110	120	140	150					
	200-20-007	1	1	1					Getriebe kpl.	Gear compl.	Engrenage compl.		
	200-20-008				1	1			Getriebe kpl.	Gear compl.	Engrenage compl.		
	200-20-009						1	1	Getriebe kpl.	Gear compl.	Engrenage compl.		
1	039-02-003	1	1	1	1	1	1	1	Radialwellendichtring	Rotary shaft seal	Bague rad. à lèvres	3760	35x72x10
2	023-02-010	8	8	8	8	8	8	8	Sechskantschraube	Hexagon head screw	Vis hexagonale	933	M 8x25
3	004-01-002	8	8	8	8	8	8	8	Federring	Spring washer	Rondelle ressort	127	φ 8
4	200-21-006	1	1	1	1	1	1	1	Flansch	Flange	Bride		
5	031-01-063	2	2	2	2	2	2	2	Paßscheibe	Shim ring	Rondelle d'ajustage	988	56x72x0,1
	031-01-064	2	2	2	2	2	2	2	Paßscheibe	Shim ring	Rondelle d'ajustage	988	56x72x0,3
6	016-01-001	1	1	1	1	1	1	1	Kegelrollenlager	Tapered roller bearing	Roulelle à galets con	720	30207
7	200-21-009	1	1	1	1	1	1	1	Kegelrad	Bevel gear	Roue conique		
8	200-21-007	1	1	1	1	1	1	1	Antriebswelle	Driving shaft	Arbre d'entraînement		
9	200-21-005	1	1	1	1	1	1	1	Getriebegehäuse	Housing	Carter		
10	011-01-015	2	2	2	2	2	2	2	Sicherungsring	Circlip	Circlip	472	φ 72
11	068-01-001	1	1	1	1	1	1	1	Entlüfter	Vent valve	Reniflard		M16x1,5
12	012-01-007	1	1	1	1	1	1	1	Rillenkugellager	Ball bearing	Roulement rainuré	625	6007
13	122-01-003	1	1	1	1	1	1	1	Verschlußdeckel	Cover	Couvercle	420	φ 72
14	023-02-007	3	3	3	3	3	3	3	Sechskantschraube	Hexagon head screw	Vis hexagonale	933	M 8x12
15	055-01-002	3	3	3	3	3	3	3	Scheibe	Washer	Rondelle	9021	φ 8,4
16	230-21-017	1	1	1	1	1	1	1	Schutztopf	Protective funnel	Pot de protection		
Winkelgetriebe											Baugruppe: 20		
Bevel gear													
Engrenage conique													
Seite: 1													

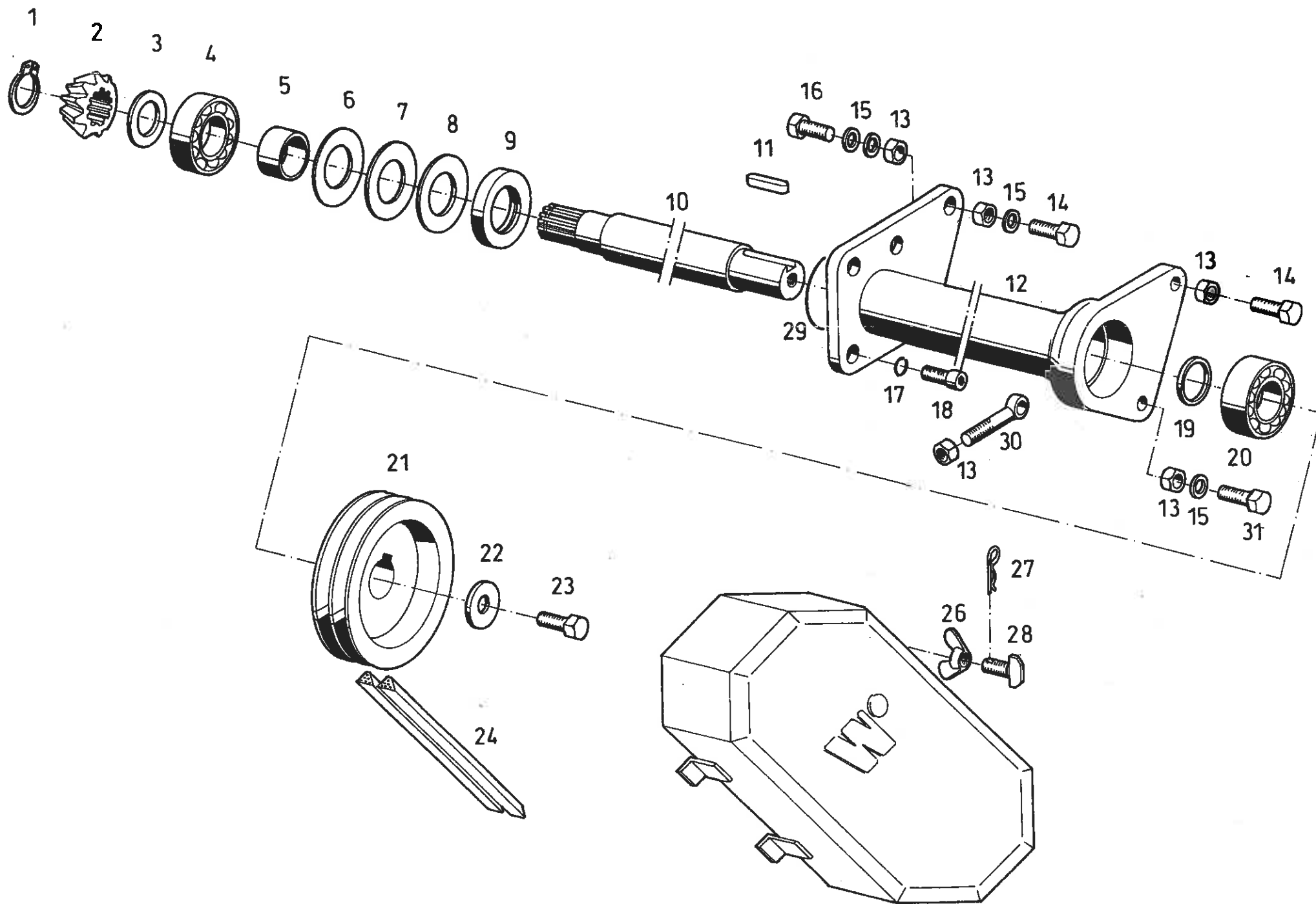

Pos.	Teile-Nr. Part-Nr. Piece-Nr	Quant.							Benennung	Description	Dé signation	DIN Norm	Maße Dimens.
		80	90	100	110	120	140	150					
1	010-01-002	1	1	1	1	1	1	1	Sicherungsring	Circlip	Circlip	471	φ 35
2	200-21-010	1	1	1	1	1	1	1	Kegelrad	Bevel gear	Roue conique		
3	031-01-018	1	1	1	1	1	1	1	Paßscheibe	Shim ring	Rondelle d'ajustage	988	35x45x0,3
4	012-01-009	1	1	1	1	1	1	1	Rillenkugellager	Ball bearing	Roulement rainuré	625	6307
5	200-21-023	1	1	1	1	1	1	1	Buchse	Bush	Douille		
6	031-01-046	1	1	1	1	1	1	1	Paßscheibe	Shim ring	Rondelle d'ajustage	988	63x80x0,1
7	031-01-066	1	1	1	1	1	1	1	Paßscheibe	Shim ring	Rondelle d'ajustage	988	63x80x0,3
8	031-01-047	1	1	1	1	1	1	1	Paßscheibe	Shim ring	Rondelle d'ajustage	988	63x80x0,5
9	039-02-004	1	1	1	1	1	1	1	Radialwellendichtring	Rotary shaft seal	Bague radiale à lèvres	3760	40x62x7
10	200-21-011	1	1	1					Abtriebswelle	Driving shaft	Arbre d'entraînement		
	200-21-012				1	1			Abtriebswelle	Driving shaft	Arbre d'entraînement		
	200-21-013						1	1	Abtriebswelle	Driving shaft	Arbre d'entraînement		
11	042-01-011	1	1	1	1	1	1	1	Paßfeder	Feather key	Ressort d'ajustage	6885	12x12x52
12	200-21-014	1	1	1					Flanschrohr	Flange pipe	Tube bride		
	200-21-015				1	1			Flanschrohr	Flange pipe	Tube bride		
	200-21-016						1	1	Flanschrohr	Flange pipe	Tube bride		
13	029-01-005	5	5	5	5	5	5	5	Sechskantmutter	Hexagon nut	Ecrou hexagonal	980	M12
14	023-02-025	2	2	2	2	2	2	2	Sechskantschraube	Hexagon head screw	Vis hexagonale	933	M12x35
15	003-02-004	4	4	4	4	4	4	4	Scheibe	Washer	Rondelle	125	B13
16	023-02-026	1	1	1	1	1	1	1	Sechskantschraube	Hexagon head screw	Vis hexagonale	933	M12x40
17	004-01-004	4	4	4	4	4	4	4	Federring	Spring washer	Rondelle ressort	127	φ 12
18	020-01-012	4	4	4	4	4	4	4	Zylinderschraube	Hex.sock.head cap screw	Vis cylindrique	912	M12x30
Antrieb											Baugruppe: 20		
Drive													
Entraînement													
Seite: 2													

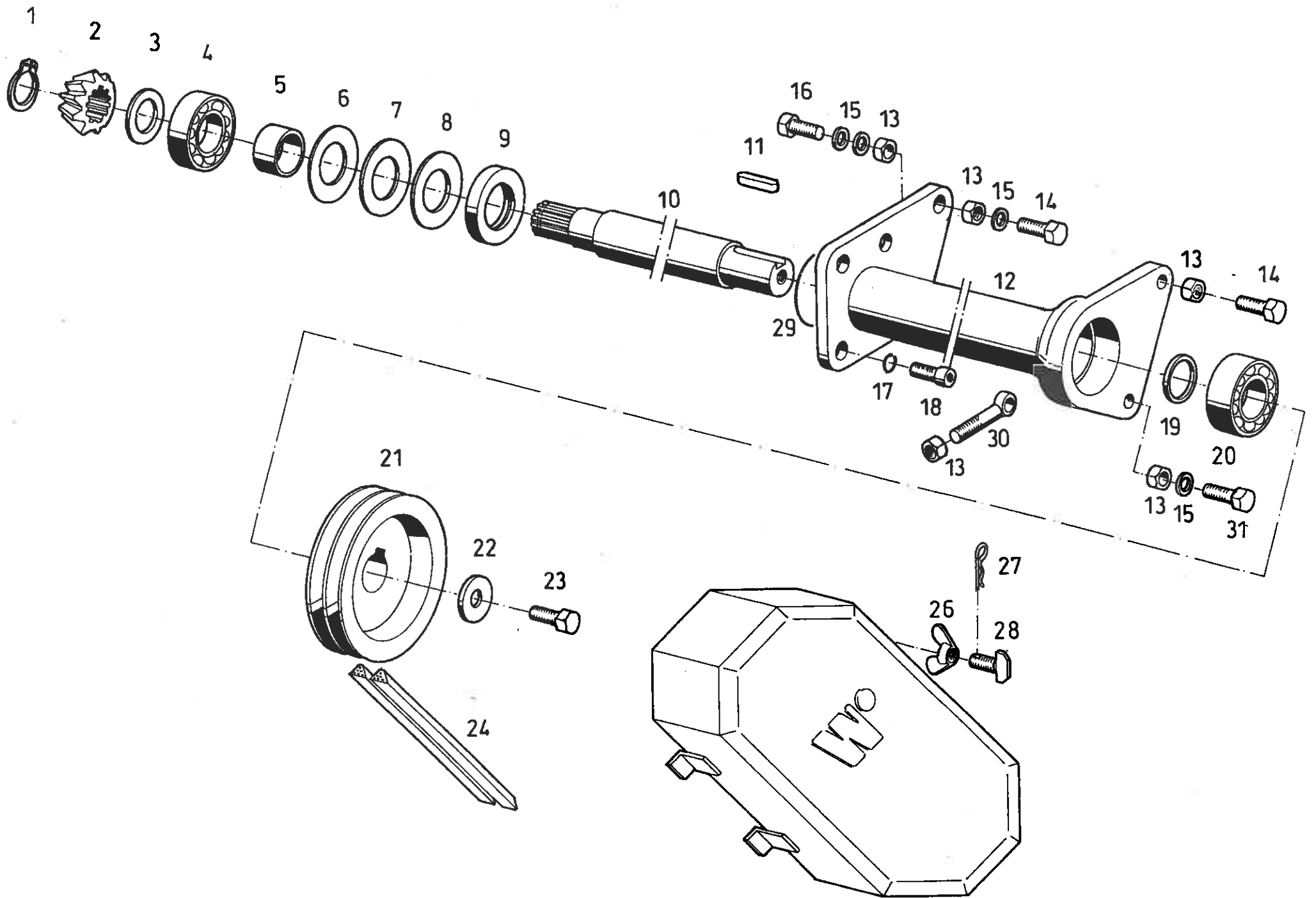

Pos.	Teile-Nr. Part-Nr. Piece-Nr.	Quant.							Benennung	Description	Dé signation	DIN Norm	Maße Dimens.
		80	90	100	110	120	140	150					
19	031-02-001	1	1	1	1	1	1	1	Scheibe	Washer	Rondelle	988	φ 35x45x2
20	012-05-009	1	1	1	1	1	1	1	Rillenkugellager	Ball bearing	Roulement raniuré	625	6307ZZ
21	210-21-001	1	1	1	1	1	1	1	Keilriemenscheibe	V-belt pulley	Poulie		
22	230-41-042	1	1	1	1	1	1	1	Scheibe	Washer	Rondelle		
23	023-06-004	1	1	1	1	1	1	1	Sechskantschraube	Hexagon head screw	Vis hexagonale	933	M 12x35
24	047-01-001	2	2	2	2	2	2	2	Keilriemen	V-belt	Courroie	SPB 1250	
25	230-30-073	1	1	1	1	1	1	1	Keilriemenschutz	V-belt protection	Protection de courroie		
26	005-01-004	1	1	1	1	1	1	1	Flügelmutter	Win nut	Ecrou à ailes	315	M 12
27	051-01-001	1	1	1	1	1	1	1	Federstecker	Spring cotter	Clavette	11024	φ 3
28	232-30-075	1	1	1	1	1	1	1	Schraube	Screw	Vis		
29	062-01-009	1	1	1	1	1	1	1	O-Ring	O-ring	Joint torique		φ 89,5x3
30	008-01-002	1	1	1	1	1	1	1	Augenschraube	Eye bolt	Boulon à oeillet	444	M 12x140
31	022-02-015	1	1	1	1	1	1	1	Sechskantschraube	Hexagon head screw	Vis hexagonale	931	M 12x70
Antrieb										Baugruppe: 20			
Drive													
Entraînement													
												Seite: 3	

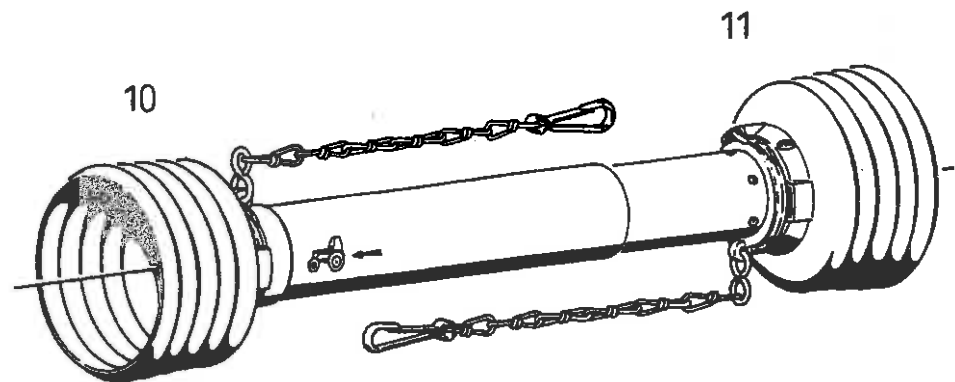
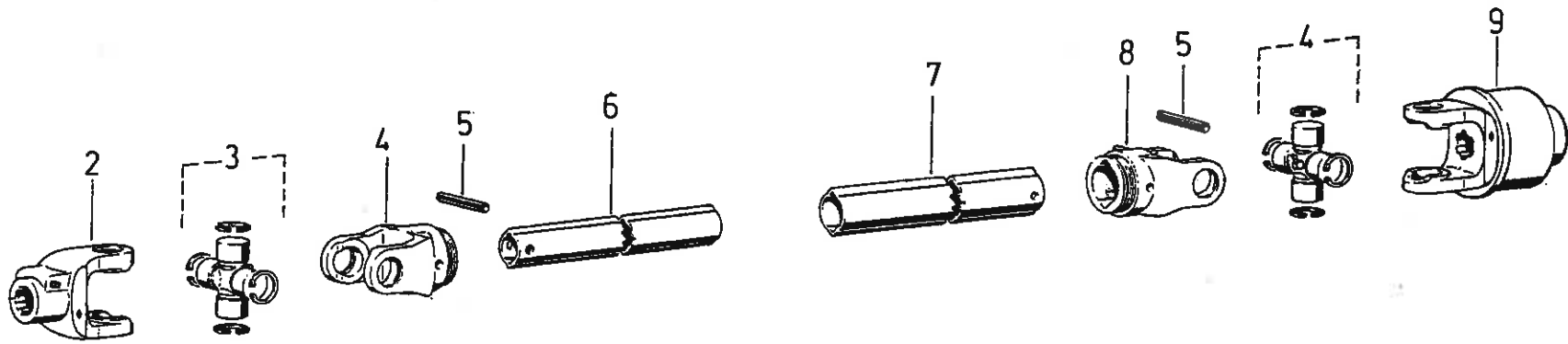
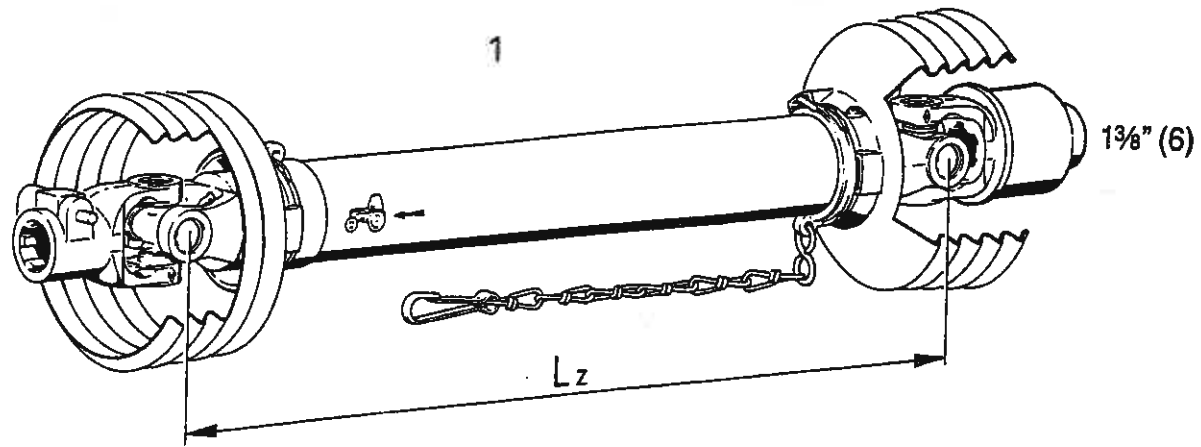

Pos.	Teile-Nr. Part-Nr. Piece-Nr	Quant.							Benennung	Description	Dé signation	DIN Maße Norm Dimens.
		80	90	100	110	120	140	150				
* 1	125-01-010	1	1	1	1	1			Gelenkwelle W2300-F5/1R	PTO shaft	Transmission cpl.	1 3/8" 6-tlg.
	125-01-012	1	1	1	1	1			Gelenkwelle W2300-F5/1R	PTO shaft	Transmission cpl.	1 3/8" 21-tlg.
	125-01-018	1	1	1	1	1			Gelenkwelle W2300-F5/1L	PTO shaft	Transmission cpl.	1 3/8" 6-tlg.
	125-01-020	1	1	1	1	1			Gelenkwelle W2300-F5/1L	PTO shaft	Transmission cpl.	1 3/8" 21-tlg.
	125-02-026						1	1	Gelenkwelle W2400-F5/1R	PTO shaft	Transmission cpl.	1 3/8" 6-tlg.
	125-02-028						1	1	Gelenkwelle W2400 F5/1R	PTO shaft	Transmission cpl.	1 3/8" 21-tlg.
	125-02-034						1	1	Gelenkwelle W2400 F5/1L	PTO shaft	Transmission cpl.	1 3/8" 6-tlg.
	125-02-036						1	1	Gelenkwelle W2400 F5/1L	PTO shaft	Transmission cpl.	1 3/8" 21-tlg.
2	125-01-130	1	1	1	1	1			Aufsteckgabel W2300	Quick disconnet yoke	Mâchoire à verrouillage	1 3/8" 6-tlg.
	125-01-132	1	1	1	1	1			Aufsteckgabel W2300	Quick disconnet yoke	Mâchoire à verrouillage	1 3/8" 21-tlg.
	125-02-162						1	1	Aufsteckgabel W2400	Quick disconnet yoke	Mâchoire à verrouillage	1 3/8" 6-tlg.
	125-02-164						1	1	Aufsteckgabel W2400	Quick disconnet yoke	Mâchoire à verrouillage	1 3/8" 21-tlg.
3	125-01-114	2	2	2	2	2			Kreuzgarnitur W2300	Cross and bearing kit	Crossillon cpl.	
	125-02-142						2	2	Kreuzgarnitur W2400	Cross and bearing kit	Crossillon cpl.	
4	125-01-116	1	1	1	1	1			Rillengabel W2300	Inboard yoke	Mâchoire à gorge	
	125-01-144						1	1	Rillengabel W2400	Inboard yoke	Mâchoire à gorge	
5	125-01-118	2	2	2	2	2			Spannstift W2300	Spring pin	Goupille elastique	1481
	125-02-146						2	2	Spannstift W2400	Spring pin	Goupille elastique	1481
6	125-01-120	1	1	1	1	1			Profilrohr in. W2300	Inner profil tube	Tube profile int.	
	125-02-148						1	1	Profilrohr in. W2400	Inner profil tube	Tube profile int.	
Gelenkwelle mit Freilaufkupplung										Baugruppe: 20		
PTO shaft with Overrunning clutch										Seite: 4		
Transmission avec roue libre à rochets										* bei Bestellung bitte Gelenkwellentype angeben		

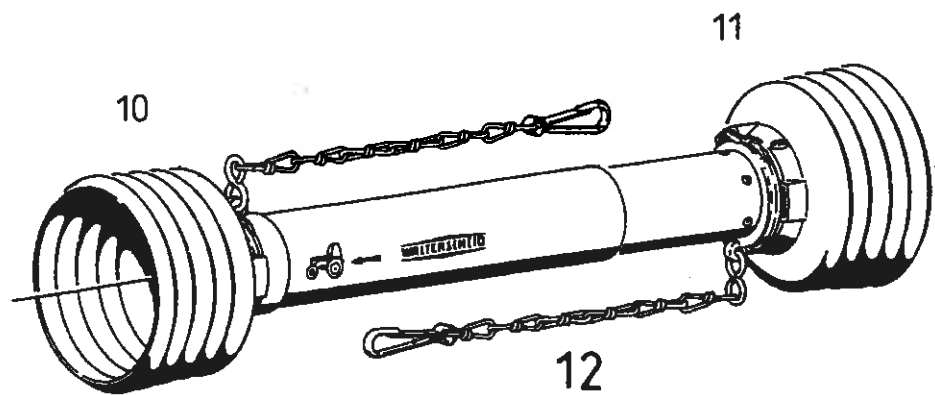
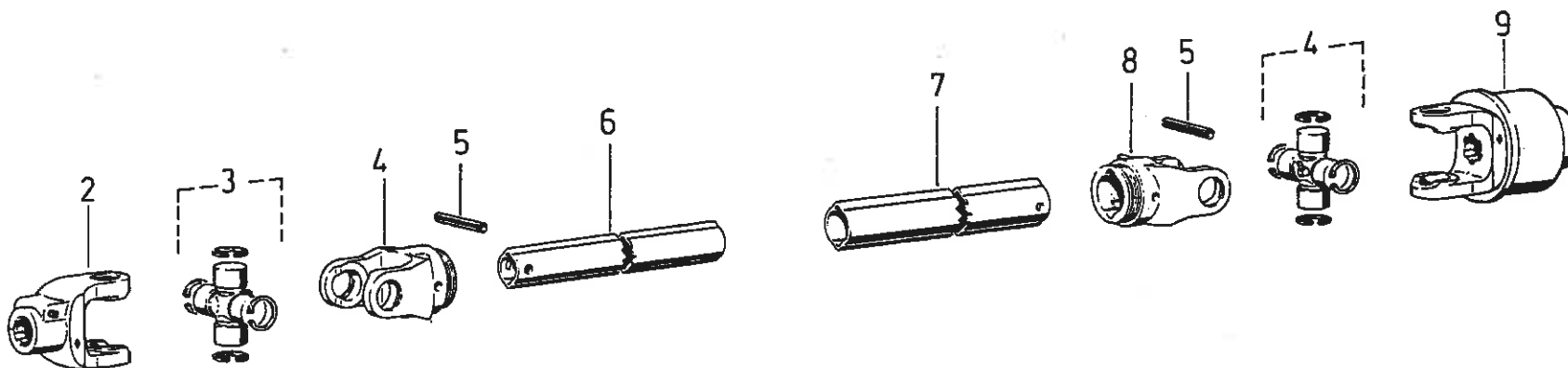
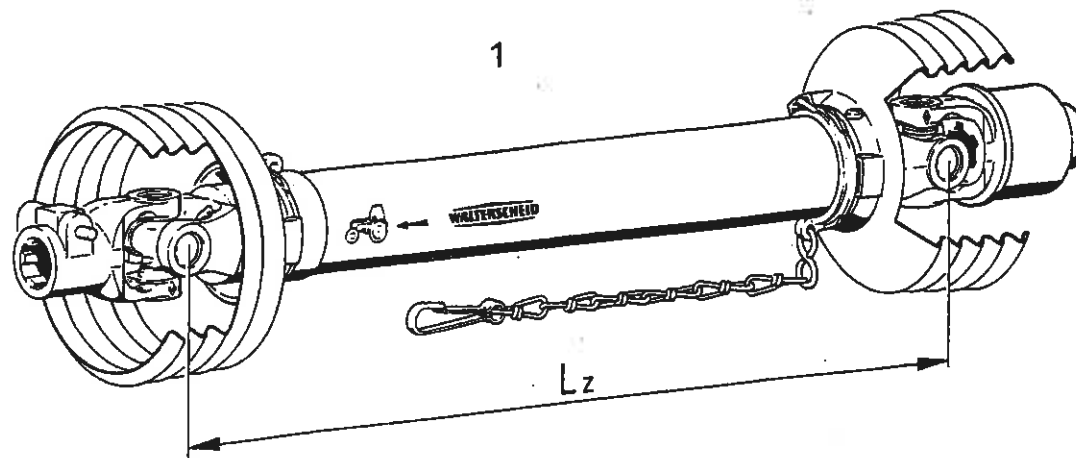

Pos.	Teile-Nr. Part-Nr. Piece-Nr	Quant.							Benennung	Description	Dé signation	DIN Maße Norm Dimens.
		80	90	100	110	120	140	150				
7	125-01-122	1	1	1	1	1			Profilrohr außen W2300	Outer profil tube	Tube profile ext.	
	125-02-154						1	1	Profilrohr außen W2400	Outer profil tube	Tube profile ext.	
8	125-01-124	1	1	1	1	1			Rillengabel W2300	Inboard yoke	Mâchoire à gorge	
	125-02-160						1	1	Rillengabel	Inboard yoke	Mâchoire à gorge	
9	125-01-126	1	1	1	1	1			Freilaufkupplung F5/1R	Overrunning clutch	Roue libre à rochets	1 3/8" 6-tlg.
	125-01-128	1	1	1	1	1			Freilaufkupplung F5/1L	Overrunning clutch	Roue libre à rochets	1 3/8" 6-tlg.
	125-02-178						1	1	Freilaufkupplung F5/1R	Overrunning clutch	Roue libre à rochets	1 3/8" 6-tlg.
	125-02-180						1	1	Freilaufkupplung F5/1L	Overrunning clutch	Roue libre à rochets	1 3/8" 6-tlg.
10	125-01-148	1	1	1	1	1			Schutzhälfte außen W2300	Outer guard half	Demi-protecteur ext.	
	125-02-195						1	1	Schutzhälfte außen W2400	Outer guard half	Demi-protecteur ext.	
11	125-01-150	1	1	1	1	1			Schutzhälfte innen W2300	Inner guard half	Demi-protecteur int.	
	125-02-206						1	1	Schutzhälfte innen W2400	Inner guard half	Demi-protecteur int.	
12	125-01-160	2	2	2	2	2	2	2	Haltekette	Safety chain	Chaînette	
Gelenkwelle mit Freilaufkupplung										Baugruppe: 20		
PTO-shaft with Overrunning clutch												
Transmission avec roue libre à rochets										Seite: 5		

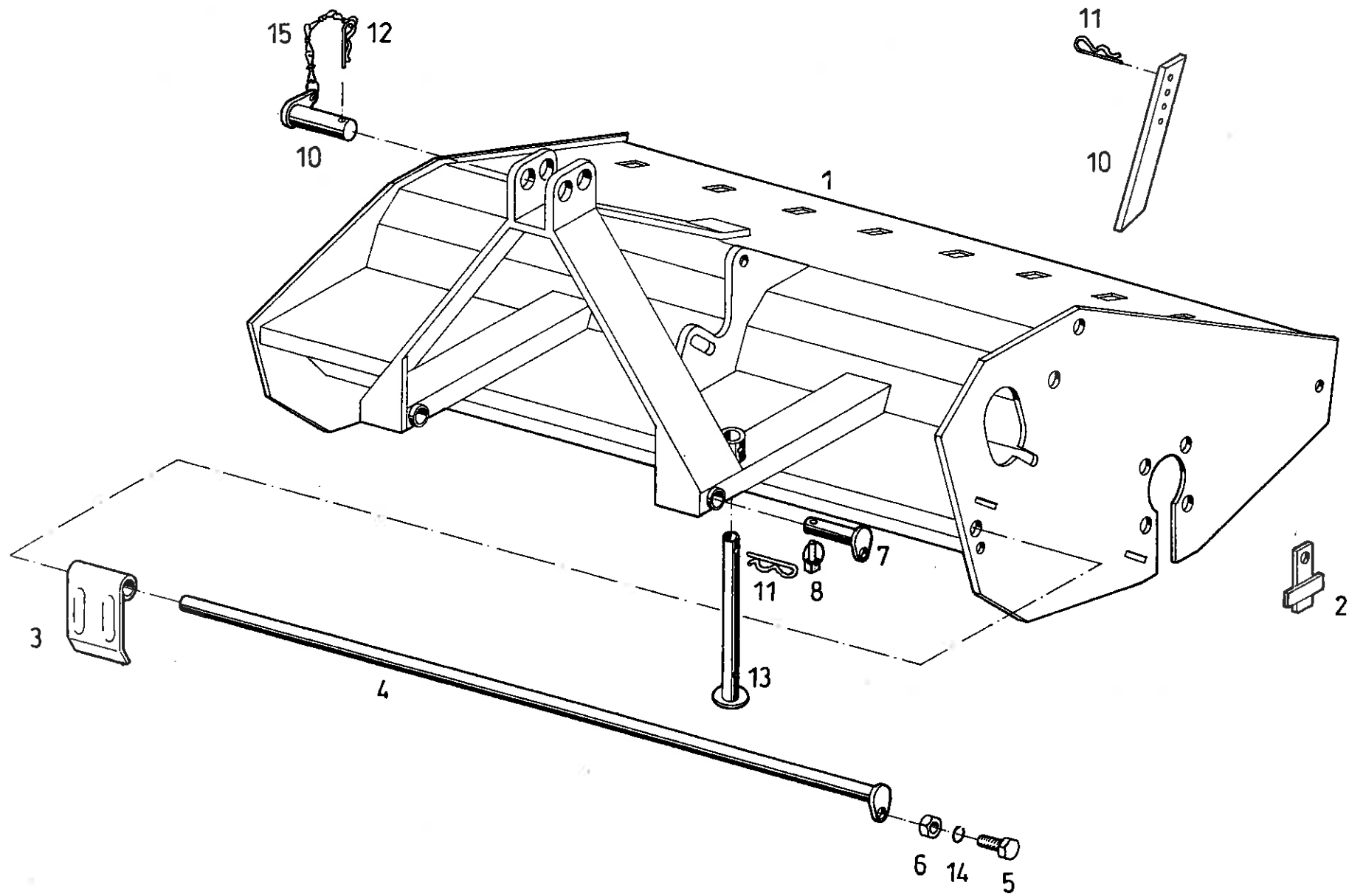

Pos.	Teile-Nr. Part-Nr. Piece-Nr.	Quant.							Benennung	Description	Désignation	DIN Norm	Maße Dimens.
		80	90	100	110	120	140	150					
1	210-30-001	1							Hauptrahmen	Main frame	Cadre principal		
	210-30-002		1						Hauptrahmen	Main frame	Cadre principal		
	210-30-003			1					Hauptrahmen	Main frame	Cadre principal		
	210-30-004				1				Hauptrahmen	Main frame	Cadre principal		
	210-30-005					1			Hauptrahmen	Main frame	Cadre principal		
	210-30-006						1		Hauptrahmen	Main frame	Cadre principal		
	210-30-007							1	Hauptrahmen	Main frame	Cadre principal		
2	210-30-010	1	1	1	1	1	1	1	Einsetzblech	Plate	Tôle		
3	232-31-068	6	6	6	8	9	9	10	Klappe	Flap	Volet		
	232-31-098		2		2	2	4	4	Klappe	Flap	Volet		
	232-31-099			3					Klappe	Flap	Volet		
4	210-30-011	1							Haltestange	Supporting rod	Tige support		
	210-30-012		1						Haltestange	Supporting rod	Tige support		
	210-30-013			1					Haltestange	Supporting rod	Tige support		
	210-30-014				1				Haltestange	Supporting rod	Tige support		
	210-30-015					1			Haltestange	Supporting rod	Tige support		
	210-30-016						1		Haltestange	Supporting rod	Tige support		
	210-30-017							1	Haltestange	Supporting rod	Tige support		
5	023-02-014	1	1	1	1	1	1	1	Sechskantschraube	Hexagon head screw	Vis hexagonale	DIN 933	M10x20
6	029-01-004	1	1	1	1	1	1	1	Sechskantmutter	Hexagon nut	Ecrou hexagonale	DIN 980	M10
Hauptrahmen											Baugruppe: 30		
Main frame													
Cadre principal											Seite: 6		

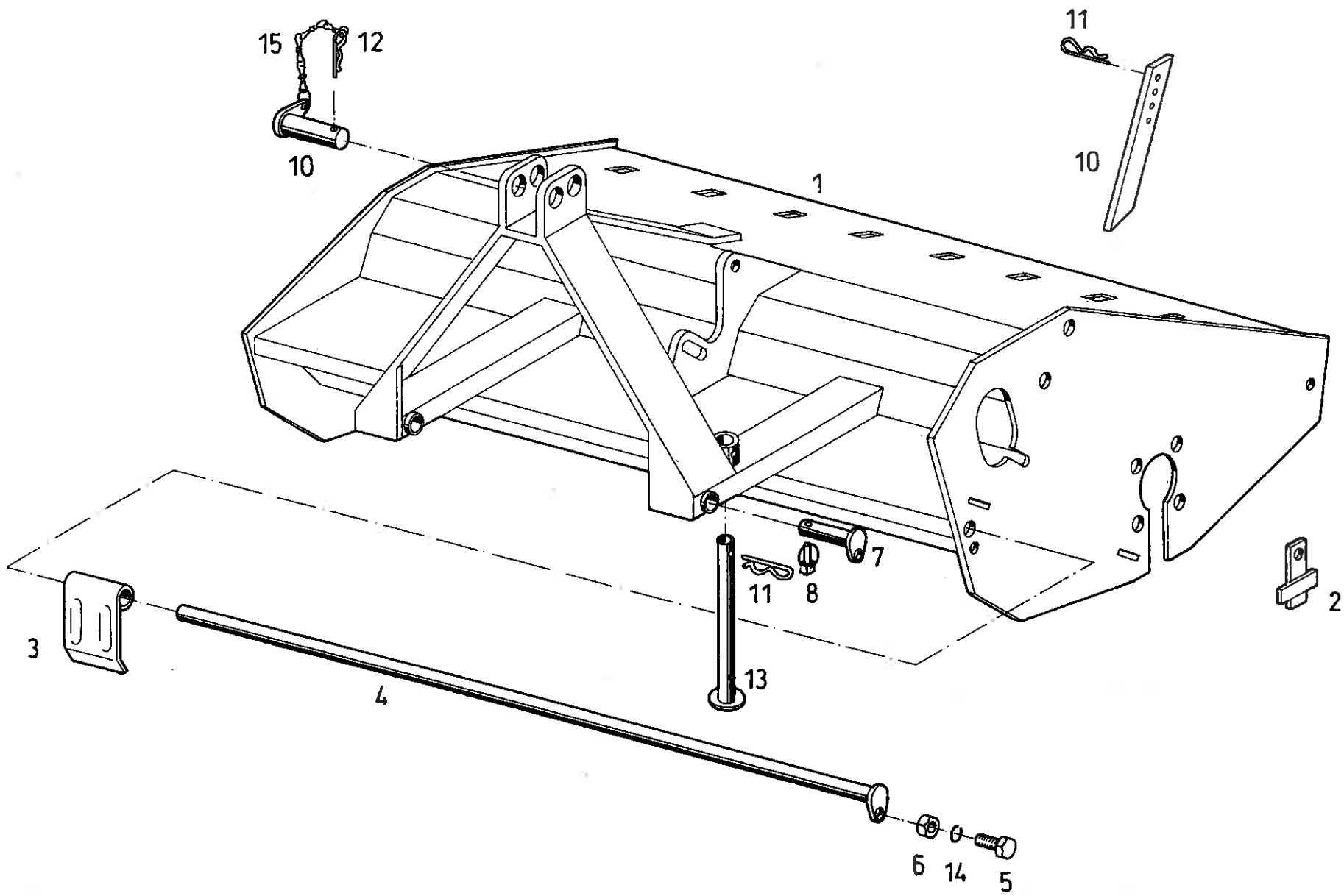

Pos.	Teile-Nr. Part-Nr. Piece-Nr	Quant.							Benennung	Description	Dé signation	DIN Norm	Maße Dimens.
		80	90	100	110	120	140	150					
7	230-30-178	2	2	2	2	2	2	2	Unterlenkerbolzen	Bottom link pin	Boulon de direct.inf.		
8	050-01-001	2	2	2	2	2	2	2	Klappstecker	Folding plug	Clavette pliante	11023	φ 9,5
9	230-30-163	1	1	1	1	1	1	1	Oberlenkerbolzen	Top link pin	Boulon de direct.sup.		
10	230-31-214	6	6	7	8	9	10	11	Zinken	Tine	Dent		
11	051-01-002	7	7	8	9	10	11	12	Federstecker	Spring cotter	Clavette	11024	φ 4
12	051-01-001	1	1	1	1	1	1	1	Federstecker	Spring cotter	Clavette	11024	φ 3
13	232-30-181	1	1	1	1	1	1	1	Stützfuß	Support	Pie de appui		
14	004-01-003	1	1	1	1	1	1	1	Federring	Spring washer	Rondelle ressort	127	φ 10
15	059-03-001	1	1	1	1	1	1	1	Knotenkette	Chain	Chaine	5686	φ2x200
Hauptrahmen											Baugruppe: 30		
Main frame													
Cadre principal											Seite: 7		

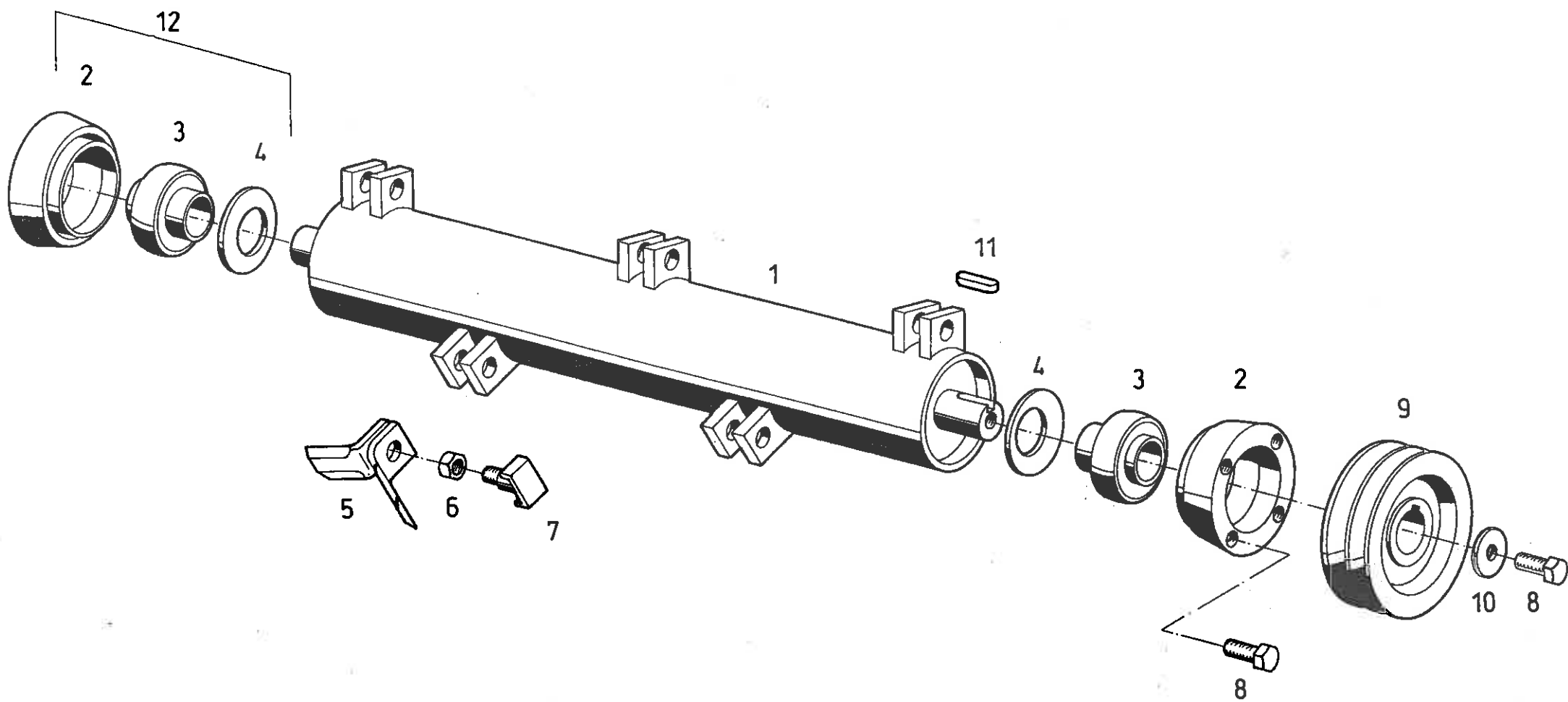

Pos.	Teile-Nr. Part-Nr. Piece-Nr	Quant.							Benennung	Description	Dé signation	DIN Maße	
		80	90	100	110	120	140	150				Norm	Dimens.
1	210-40-002	1							Schlegelwelle	Flail shaft	Arbre de fléaux		
	210-40-003		1						Schlegelwelle	Flail shaft	Arbre de fléaux		
	210-40-004			1					Schlegelwelle	Flail shaft	Arbre de fléaux		
	210-40-005				1				Schlegelwelle	Flail shaft	Arbre de fléaux		
	210-40-006					1			Schlegelwelle	Flail shaft	Arbre de fléaux		
	210-40-008						1		Schlegelwelle	Flail shaft	Arbre de fléaux		
	210-40-009							1	Schlegelwelle	Flail shaft	Arbre de fléaux		
2	102-41-005	2	2	2	2	2	2	2	Lagergehäuse	Bearing housing	Carter de palier		
3	060-01-002	2	2	2	2	2	2	2	Rillenkugellager	Ball bearing	Roulement rainuré		
4	280-71-009	2	2	2	2	2	2	2	Deckscheibe	Cover disk	Disque d` obturat.		
5	210-41-002	28	30	34	38	40	48	52	Klinge	Blade	Lame		
6	029-01-007	14	15	17	19	20	24	26	Sechskantmutter	Hexagon nut	Ecrou hexagonale	980	M16
7	210-40-001	14	15	17	19	20	24	26	Klingenbolzen	Bolt	Boulon		
8	023-06-004	9	9	9	9	9	9	9	Sechskantschraube	Hexagon head screw	Vis hexagonale	933	M12x35
9	210-41-001	1	1	1	1	1	1	1	Keilriemenscheibe	V-belt pulley	Poulie		
10	230-41-042	1	1	1	1	1	1	1	Scheibe	Washer	Rondelle		
11	042-01-011	1	1	1	1	1	1	1	Paßfeder	Feather key	Ressort d`ajustage	6885	12x12x52
12	210-40-019	2	2	2	2	2	2	2	Lagerung kpl.	Bearing compl.	Roulement compl.		
13	210-40-027	1							Schlegelwelle mont.	Flail shaft compl.	Arbre de fléaux compl.		
	210-40-028		1						Schlegelwelle mont.	Flail shaft compl.	Arbre de fléaux compl.		
	210-40-029			1					Schlegelwelle mont.	Flail shaft compl.	Arbre de fléaux compl.		
Schlegelwelle											Baugruppe: 40		
Flail shaft													
Arbre de fléaux											Seite: 8		

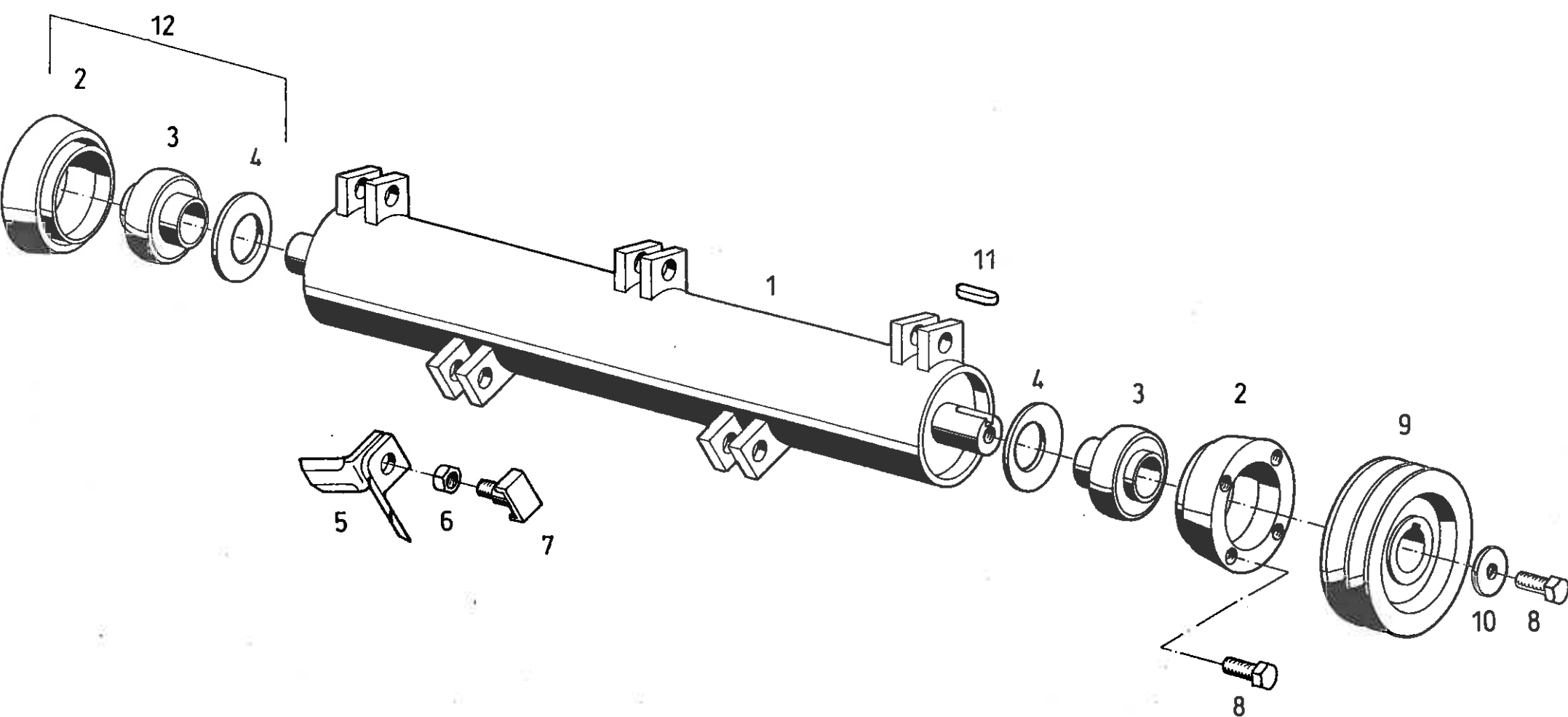

Pos.	Teile-Nr. Part-Nr. Piece-Nr.	Quant.							Benennung	Description	Dé signation	DIN Maße Norm Dimens.
		80	90	100	110	120	140	150				
13	210-40-030				1				Schlegelwelle mont.	Flail shaft compl.	Arbre de fléaux compl.	
	210-40-031					1			Schlegelwelle mont.	Flail shaft compl.	Arbre de fléaux compl.	
	210-40-032						1		Schlegelwelle mont.	Flail shaft compl.	Arbre de fléaux compl.	
	210-40-033							1	Schlegelwelle mont.	Flail shaft compl.	Arbre de fléaux compl.	
Schlegelwelle											Baugruppe: 40	
Flail shaft												
Arbre de fléaux												
											Seite: 9	

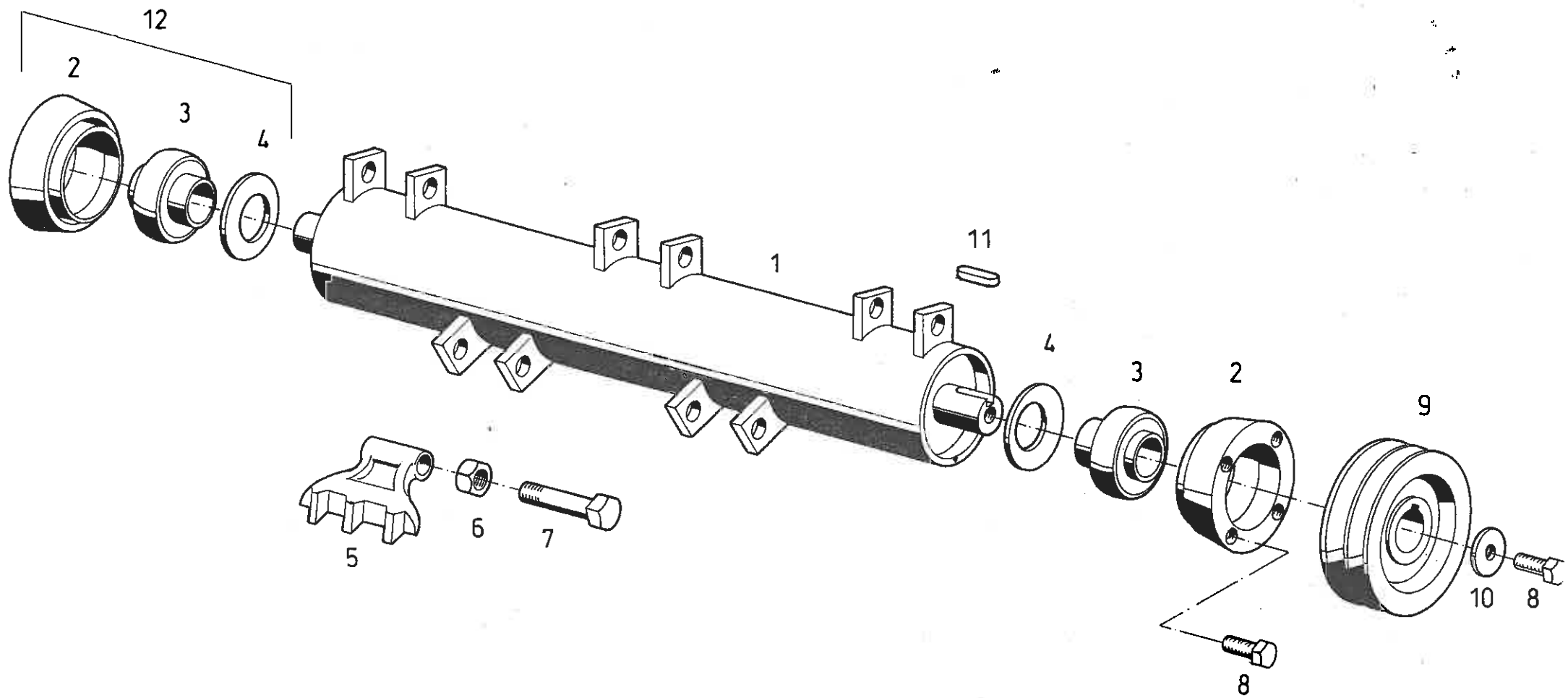

Pos.	Teile-Nr. Part-Nr. Piece-Nr	Quant.							Benennung	Description	Dé signation	DIN Norm	Maße Dimens.
		80	90	100	110	120	140	150					
1	210-40-010	1							Schlegelwelle	Flail shaft	Arbre de flèaux		
	210-40-011		1						Schlegelwelle	Flail shaft	Arbre de flèaux		
	210-40-012			1					Schlegelwelle	Flail shaft	Arbre de flèaux		
	210-40-013				1				Schlegelwelle	Flail shaft	Arbre de flèaux		
	210-40-014					1			Schlegelwelle	Flail shaft	Arbre de flèaux		
	210-40-015						1		Schlegelwelle	Flail shaft	Arbre de flèaux		
	210-40-016							1	Schlegelwelle	Flail shaft	Arbre de flèaux		
2	102-41-005	2	2	2	2	2	2	2	Lagergehäuse	Bearing housing	Carter de palier		
3	060-01-002	2	2	2	2	2	2	2	Rillenkugellager	Ball bearing	Roulement rainuré		
4	280-71-009	2	2	2	2	2	2	2	Deckscheibe	Cover disk	Disque d'obturat.		
5	230-40-068	5	6	7	7	8	9	10	Zahnschlegel	Flail	Flèaux		
6	029-01-007	5	6	7	7	8	9	10	Sechskantmutter	Hexagon nut	Ecrou hexagonale	980	M20
7	232-41-006	5	6	7	7	8	9	10	Schlegelschraube	Flail bolt	Axe de flèaux		
8	023-06-004	9	9	9	9	9	9	9	Sechskantschraube	Hexagon head cap screw	Vis hexagonale	933	M12x35
9	210-41-001	1	1	1	1	1	1	1	Keilriemenscheibe	V-belt pulley	Poulie		
10	230-41-042	1	1	1	1	1	1	1	Scheibe	Washer	Rondelle		
11	042-01-011	1	1	1	1	1	1	1	Paßfeder	Feather key	Ressort d'ajustage	6885	12x12x52
12	210-40-019	2	2	2	2	2	2	2	Lagerung kpl.	Bearing compl.	Roulement compl.		
13	210-40-020	1							Schlegelwelle mont.	Flail shaft compl.	Arbre de flèaux compl.		
	210-40-021		1						Schlegelwelle mont.	Flail shaft compl.	Arbre de flèaux compl.		
	210-40-022			1					Schlegelwelle mont.	Flail shaft compl.	Arbre de flèaux compl.		
Schlegelwelle											Baugruppe: 40		
Flail shaft													
Arbre de flèaux													
											Seite: 10		

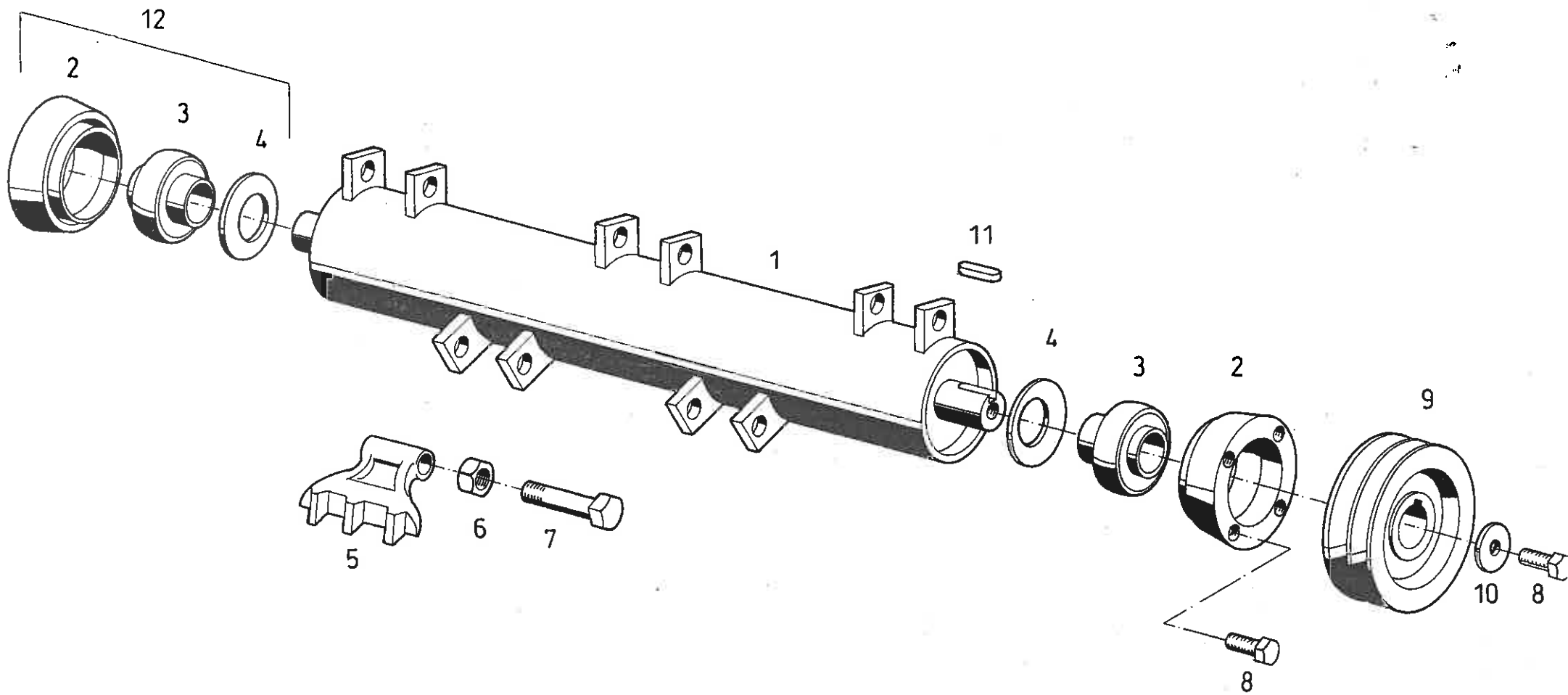

Pos.	Teile-Nr. Part-Nr. Piece-Nr	Quant.							Benennung	Description	Dé signation	DIN Maße Norm Dimens.
		80	90	100	110	120	140	150				
13	210-40-023				1				Schlegelwelle mont.	Flail shaft compl.	Arbre de flèaux compl.	
	210-40-024					1			Schlegelwelle mont.	Flail shaft compl.	Arbre de flèaux compl.	
	210-40-025						1		Schlegelwelle mont.	Flail shaft compl.	Arbre de flèaux compl.	
	210-40-026							1	Schlegelwelle mont.	Flail shaft compl.	Arbre de flèaux compl.	
Schlegelwelle											Baugruppe: 40	
Flail shaft												
Arbre de flèaux												
											Seite: 11	

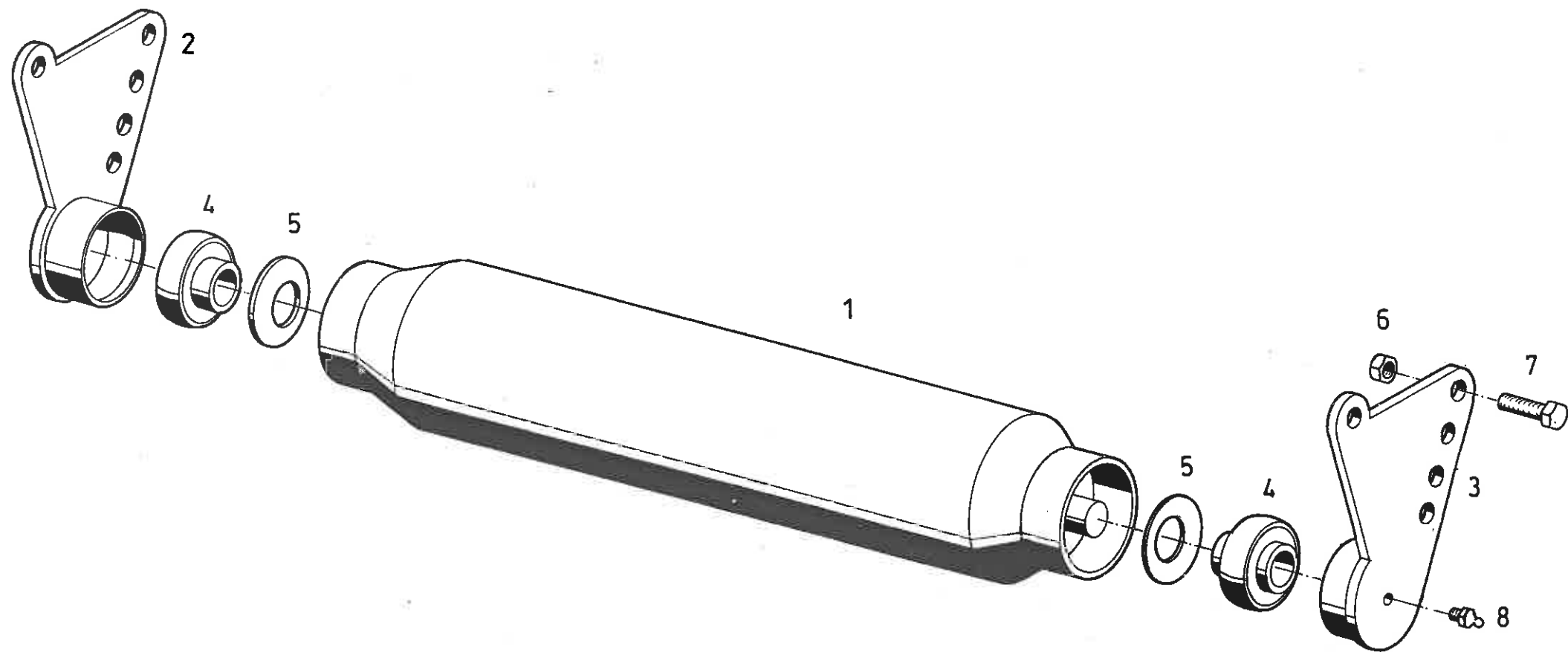

Pos.	Teile-Nr. Part-Nr. Piece-Nr	Quant.							Benennung	Description	Désignation	DIN	Maße Norm Dimens.
		80	90	100	110	120	140	150					
1	230-70-059	1							Laufwalze	Roll	Rouleau		
	230-70-058		1						Laufwalze	Roll	Rouleau		
	230-70-057			1					Laufwalze	Roll	Rouleau		
	230-70-061				1				Laufwalze	Roll	Rouleau		
	230-70-056					1			Laufwalze	Roll	Rouleau		
	230-70-063						1		Laufwalze	Roll	Rouleau		
	230-70-055							1	Laufwalze	Roll	Rouleau		
2	230-70-045	1	1	1	1	1	1	1	Laufwalzenhalter re.	Roll support right	Support de roul. dr.		
3	230-70-044	1	1	1	1	1	1	1	Laufwalzenhalter li.	Roll support left	Support de roul. g.		
4	060-01-001	2	2	2	2	2	2	2	Rillenkugellager	Ball bearing	Roulement rainuré		
5	232-71-010	2	2	2	2	2	2	2	Deckscheibe	Cover disk	Dique d'obturat.		
6	029-01-005	4	4	4	4	4	4	4	Sechskantmutter	Hexagon nut	Ecrou hexagonale	980	M12
7	023-02-026	4	4	4	4	4	4	4	Sechskantschraube	Hexagon head cap screw	Vis hexagonale	933	M12x40
8	052-01-001	2	2	2	2	2	2	2	Schmiernippel	Grease nipple	Graisseur	71412	AM 6
Laufwalze											Baugruppe: 70		
Roll													
Rouleau													
												Seite: 12	

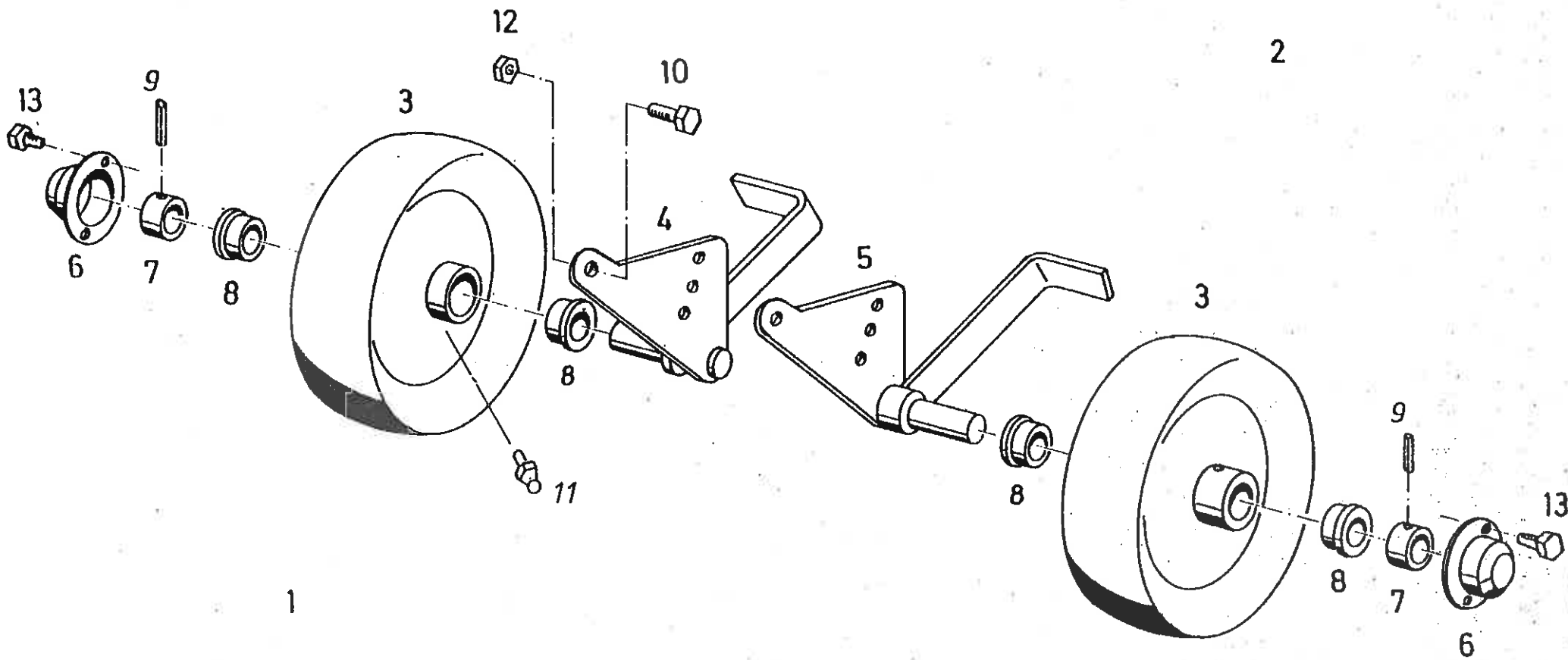

Pos.	Teile-Nr. Part-Nr. Piece-Nr	Quant.							Benennung	Description	Dé signation	DIN Maße	
		80	90	100	110	120	140	150				Norm	Dimens.
1	232-70-008	1	1	1	1	1	1	1	LaufRad rechts kpl.	Wheel right compl.	Roue droite compl.		
2	232-70-007	1	1	1	1	1	1	1	LaufRad links kpl.	Wheel left compl.	Roue gauche compl.		
3	230-70-002	2	2	2	2	2	2	2	Rad	Wheel	Roue		
4	230-70-016	1	1	1	1	1	1	1	Radhalter rechts	Wheel support right	Support de Roue dr.		
5	230-70-015	1	1	1	1	1	1	1	Radhalter links	Wheel support left	Support de Roue gauche		
6	230-71-014	2	2	2	2	2	2	2	Staubkappe	Dust cover	Chapeau de poussier		
7	230-71-013	2	2	2	2	2	2	2	Nabe	Hub	Moyeu		
8	230-71-006	4	4	4	4	4	4	4	Buchse	Bush	Douille		
9	034-01-002	2	2	2	2	2	2	2	Spannhülse	Clampin sleeve	Goupille de serrage	1481	φ 6x40
10	023-02-026	6	6	6	6	6	6	6	Sechskantschraube	Hexagon head screw	Vis hexagonale	933	M12x40
11	052-01-001	2	2	2	2	2	2	2	Schmiernippel	Grease nipple	Graisseur	71412	AM 6
12	029-01-005	6	6	6	6	6	6	6	Sechskantmutter	Hexagon nut	Ecrou hexagonale	980	M12
13	110-01-005	4	4	4	4	4	4	4	Blechschaube	Tapping screw	Vis tarandeuse	7981	6,3x32
Laufräder											Baugruppe: 70		
Wheel													
Roue													
											Seite: 13		