

Universal Forstmulchgerät

Typ UFM

Ersatzteilliste

Spare Parts Catalogue

Liste des Pièces Detachées

Lista de Repuestos

**J. Willibald GmbH
Maschinenfabrik
Bahnhofstraße 6
88639 Wald - Sentenhart
Tel.: 0 7578/ 189-0
Fax: 0 7578/ 189-150**

**J. Willibald GmbH
Service & Instandsetzungszenrum
Im Wolfsgraben 5
36414 Unterbreizbach
Tel.: +49 (0) 3 69 62 / 5 14 10
Fax.: +49 (0) 3 69 62 / 5 14 18**

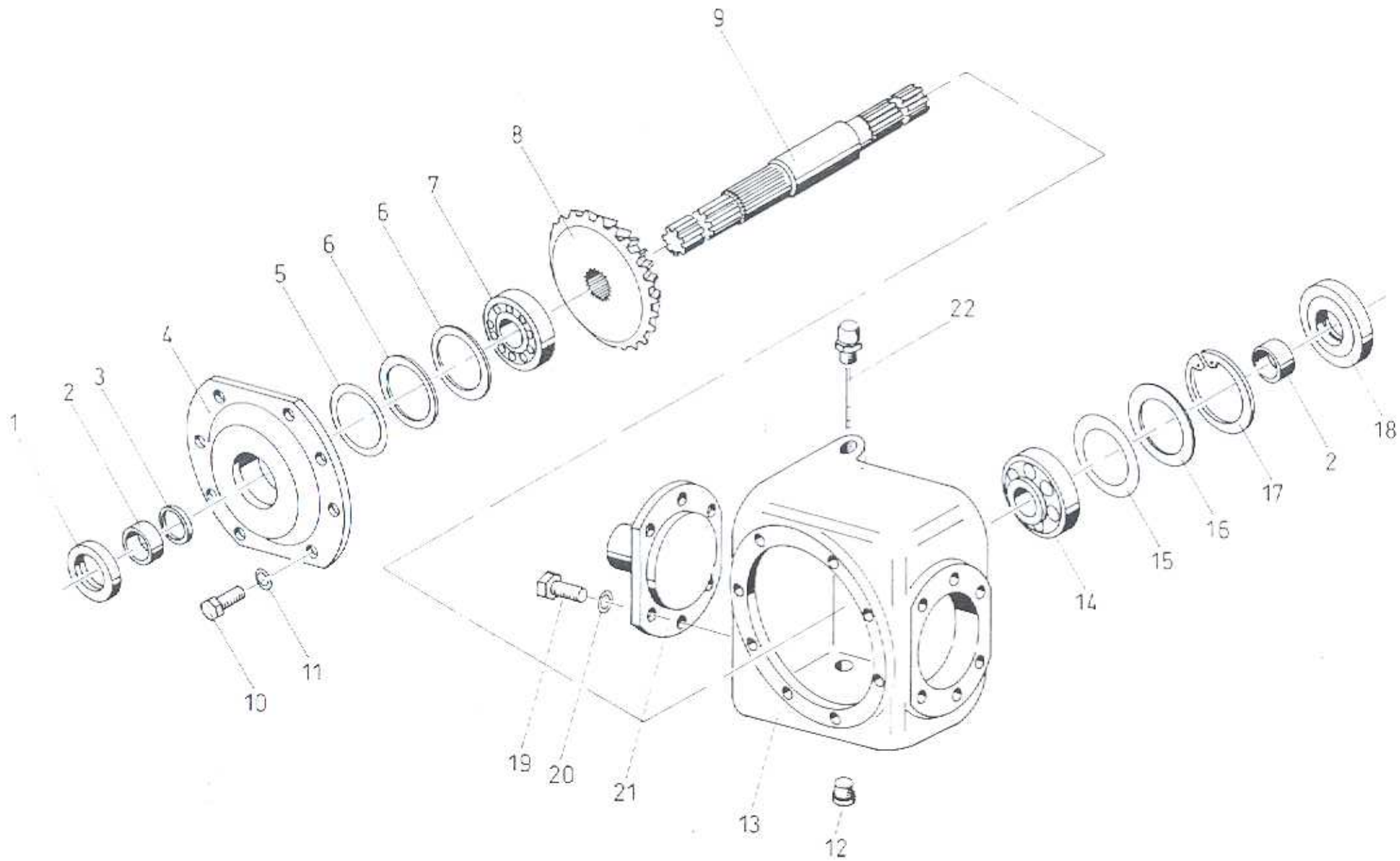

Pos.	Teile-Nr. Part-Nr. Piece-Nr.	Quant.			Benennung	Description	Désignation	DIN Norm	Maße Dimens.
		150	180	225					
	423-20-004	1			Getriebe kpl.	Gear compl.	Engrenage compl.		
	423-20-016		1	1	Getriebe kpl.	Gear compl.	Engrenage compl.		
1	039-02-018	1	1	1	Radialwellendichtung	Radial seal ring	Joint radial p. arbre	3760	55x72x10
2	423-21-013	2	2	2	Ring	Ring	Bague		
3	031-02-007	1	1	1	Stützscheibe	Supporting ring	Bague support	988	45x55x3
4	423-21-019	1	1	1	Flansch	Flange	Bride		
5	031-01-049	2	2	2	Paßscheibe	Spacer	Rondelle d'ajustage	988	65x85x0,1
	031-01-077	1	1	1	Paßscheibe	Spacer	Rondelle d'ajustage	988	65x85x0,3
	031-01-050	1	1	1	Paßscheibe	Spacer	Rondelle d'ajustage	988	65x85x0,5
6	031-02-015	2	2	2	Stützscheibe	Supporting ring	Bague support	988	65x85x3,5
7	016-01-012	1	1	1	Kegelrollenlager	Tapered roller bearing	Roulem. à galets con.	720	33209
8	423-21-017	1	1	1	Kegelrad	Bevel gear	Pignon conique	z=21	
9	423-21-014	1	1	1	Antriebswelle	Driving shaft	Arbre de commande		
10	023-02-025	8	8	8	Sechskantschraube	Hexagon head screw	Vis hexagonale	933	M12x35
11	004-01-004	8	8	8	Federring	Spring washer	Rondelle élastique	127	A12
12	019-01-003	1	1	1	Verschlussschraube	Closing screw	Bouchou fileté	908	M18x1,5
13	423-21-012	1	1	1	Gehäuse	Housing	Carter		
14	016-01-006	1	1	1	Kegelrollenlager	Tapered roller bearing	Roulem. à galets con.	720	33109
15	031-01-046	2	2	2	Paßscheibe	Spacer	Rondelle d'ajustage	988	63x80x0,1
	031-01-066	1	1	1	Paßscheibe	Spacer	Rondelle d'ajustage	988	63x80x0,3
	031-01-047	1	1	1	Paßscheibe	Spacer	Rondelle d'ajustage	988	63x80x0,5
Ersatzteilgruppe:						Winkelgetriebe UFM	Baugruppe: 80		
Spare parts group:						Bevel gear			
Groupe de pièces de rechange:						Engrenage conique			

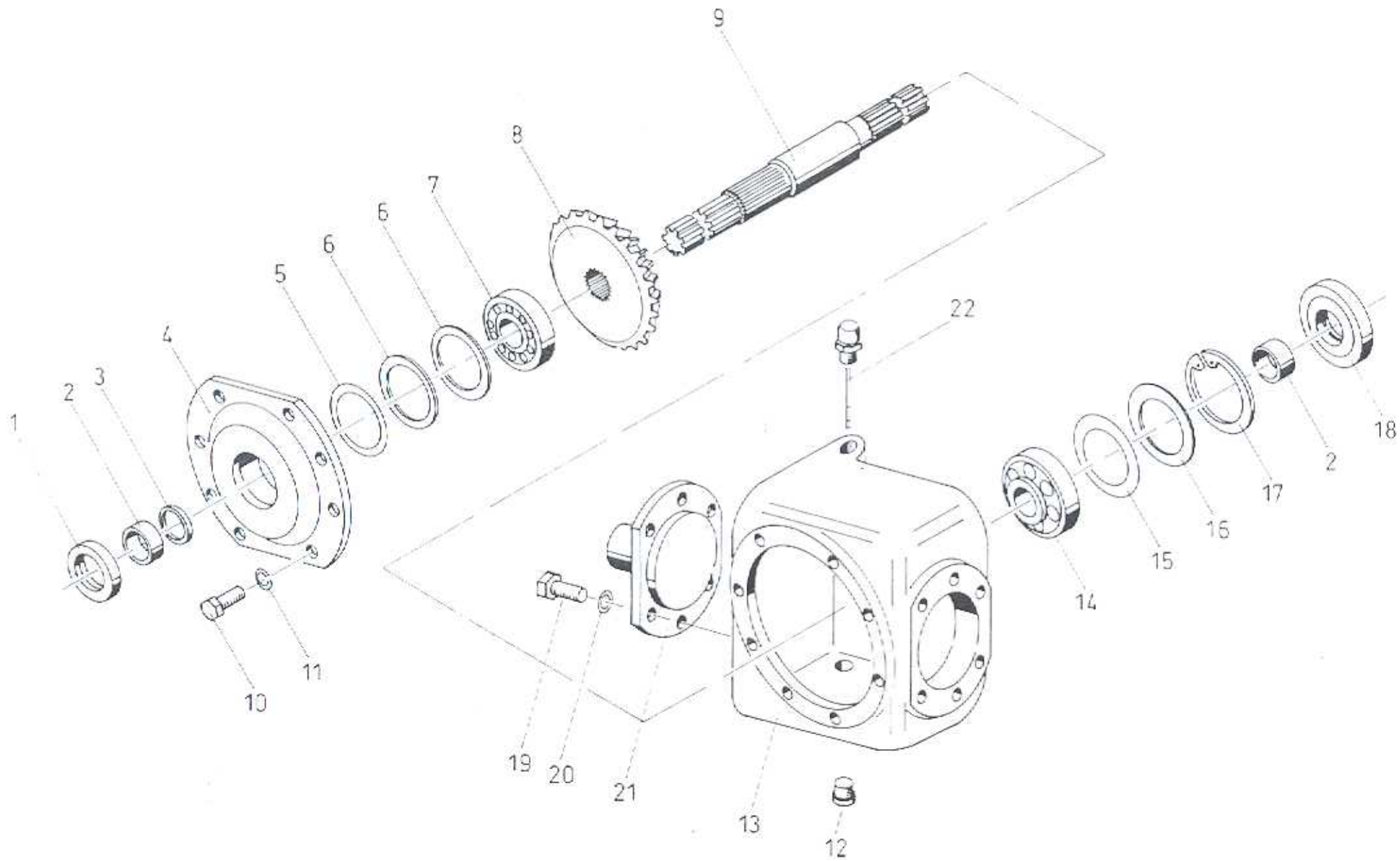

Pos.	Teile-Nr. Part-Nr. Piece-Nr.	Quant.			Benennung	Description	Désignation	DIN Norm	Maße Dimens.
		150	180	225					
16	031-02-006	1	1	1	Stützscheibe	Supporting ring	Bague support	988	63x80x3,0
17	011-01-017	1	1	1	Sicherungsring	Circlip	Circlip	472	∅ 80
18	039-02-019	1	1	1	Radialwellendichtung	Radial seal ring	Joint radial p. arbre	3760	55x80x10
19	020-01-024	12	12	12	Zylinderschraube	Pan head screw	Vis à tête cylindrique	912	M16x45
20	105-01-005	12	12	12	Federring	Spring washer	Rondelle élastique	7980	∅ 16
21	423-21-016	1	1	1	Ölmeßstab	Oil indicator	Indicateur d' huile		M18x1,5
Ersatzteilgruppe: Winkelgetriebe UFM							Baugruppe: 80		
Spare parts group: Bevel gear									
Groupe de pièces de rechange: Engrenage conique									

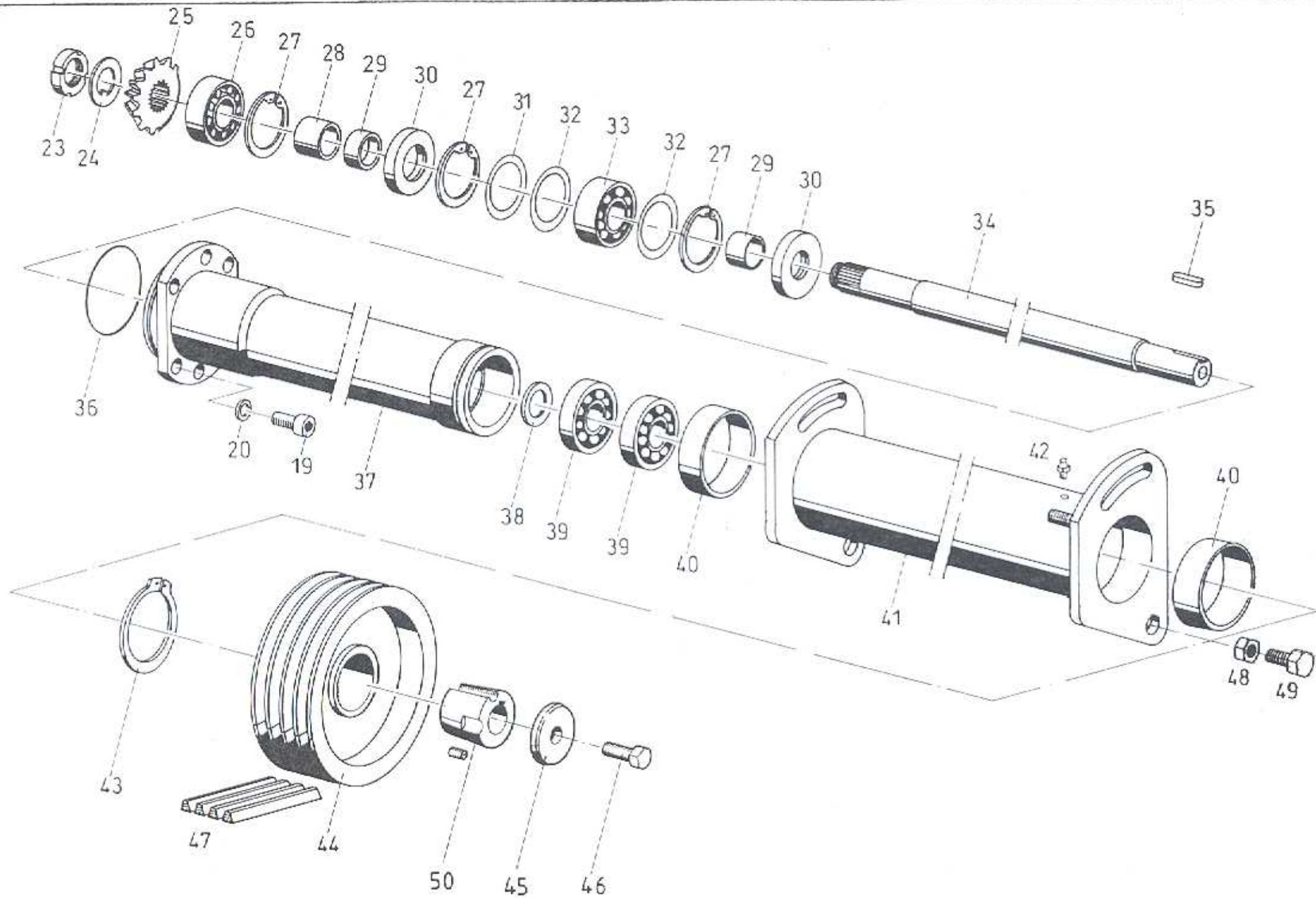

Pos.	Teile-Nr. Part-Nr. Piece-Nr.	Quant.			Benennung	Description	Désignation	DIN Norm	Maße Dimens.
		150	180	225					
23	106-01-008	1	1	1	Stirnutmutter	Shaft nut	Ecrou d'arbre	1804	M45x1,5
24	009-01-003	1	1	1	Sicherungsblech	Locking plate	Frein vis	462	∅ 45
25	423-02-006	1	1	1	Kegelrad	Bevel gear	Pignon conique		
26	040-02-006	1	1	1	Zylinderrollenlager	Cylinder roller bearing	Roulement à rouleaux cyl.	5412	NJ 2310
27	011-01-023	3	3	3	Sicherungsring	Circlip	Circlip	472	∅ 110
28	423-21-015	1	1	1	Buchse	Bush	Douille		
29	116-01-006	2	2	2	Innenring	Internal ring	Bague intérieure	620	50x60x25
30	039-01-007	2	2	2	Radialwellendichtring	Radial seal ring	Joint radial p. arbre	3760	60x110x12
31	031-01-057	2	2	2	Paßscheibe	Spacer	Rondelle d'ajustage	988	90x110x0,1
	031-01-068	1	1	1	Paßscheibe	Spacer	Rondelle d'ajustage	988	90x110x0,3
	031-01-069	1	1	1	Paßscheibe	Spacer	Rondelle d'ajustage	988	90x110x0,5
32	031-02-008	2	2	2	Stützscheibe	Supporting ring	Bague support	988	90x110x3,5
33	013-02-002	1	1	1	Schräggugellager	Angular cont. ball bear.	Roulement oblique	628	3310
34	423-21-021	1			Antriebswelle	Driving shaft	Arbre de commande		
	423-21-040		1	1	Antriebswelle	Driving shaft	Arbre de commande		
35	042-01-016	1	1	1	Paßfeder	Feather key	Ressort d'ajustage	6885	18x11x70
36	062-01-002	1	1	1	O-Ring	Ring seal	Anneau de garniture		∅ 128,7x4
37	423-20-010	1			Flanschrohr	Flange pipe	Tube bride		
	423-20-017		1	1	Flanschrohr	Flange pipe	Tube bride		
38	031-02-009	1	1	1	Stützscheibe	Supporting ring	Bague support	988	55x68x3,0
39	012-05-014	2	2	2	Rillenkugellager	Grooved ball bearing	Roulement	325	6211 ZZ
40	064-01-015	2	2	2	Lagerbuchse	Bearing bush	Coussinet		135x140x60
Ersatzteilgruppe:						Winkelgetriebe UFM	Baugruppe: 20		
Spare parts group:						Bevel gear			
Groupe de pièces de rechange:						Engrenage conique			

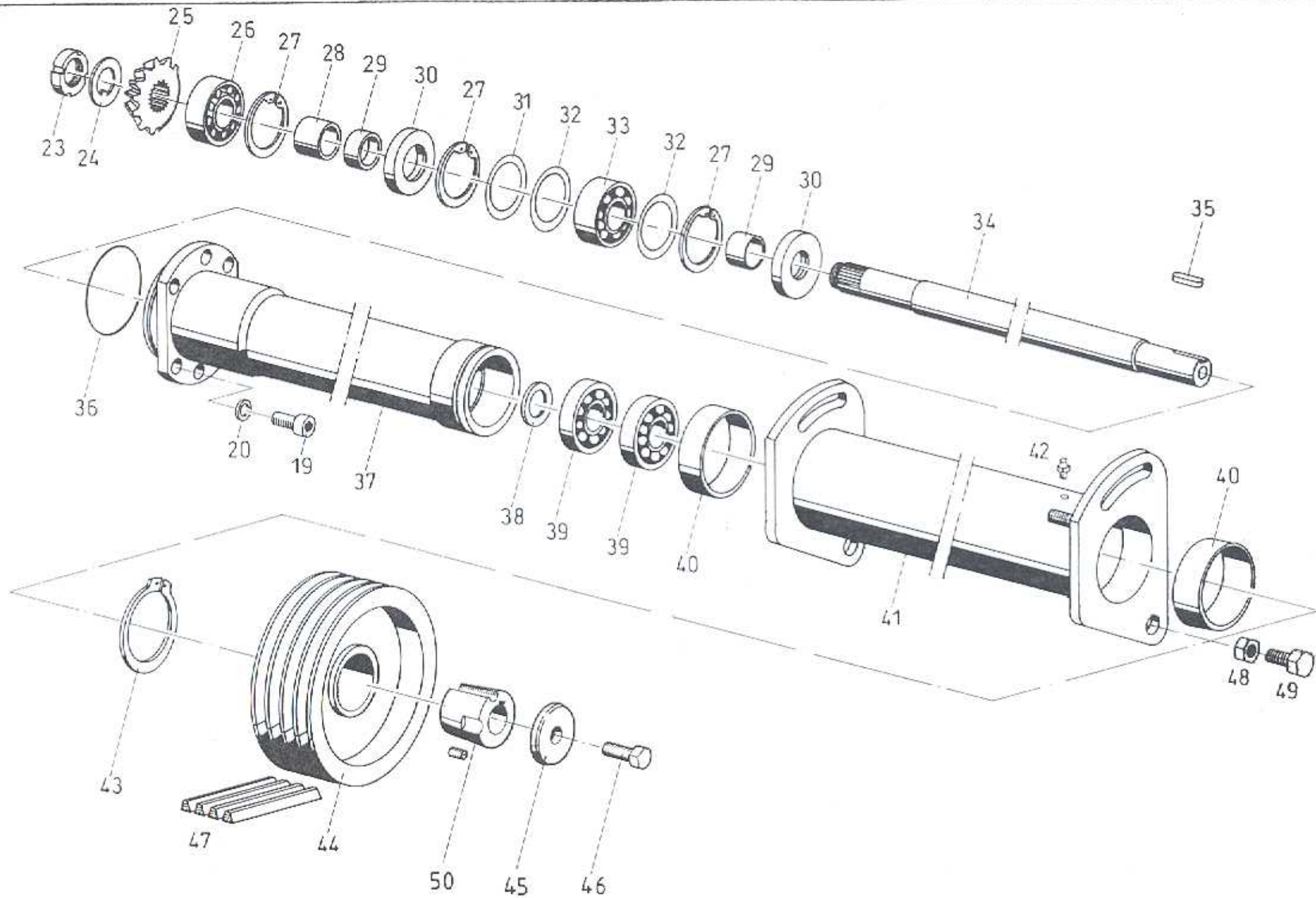

Pos.	Teile-Nr. Part-Nr. Piece-Nr.	Quant.			Benennung	Description	Désignation	DIN Norm	Maße Dimens.
		150	180	225					
41	423-20-015	1	1	1	Lagerrohr	Bearing pipe	Cousinet		
42	052-01-001	2	2	2	Schmiernippel	Grease nipple	Graisser	71412	AM6
43	010-01-021	1	1	1	Sicherungsring	Circlip	Circlip		∅ 135
44	423-21-100	1	1	1	Keilriemenscheibe	V-belt pulley	Poulie		∅ 375
45	660-41-156	1	1	1	Scheibe	Washer	Rondelle		
46	023-06-008	1	1	1	Sechskantschraube	Hexagon head screw	Vis hexagonale	933	M16x50
47	047-05-001	4	4	4	Keilriemen (Satz)	V-belt	Courroie	7753	SPC 2120
48	029-01-009	2	2	2	Sechskantmutter	Hexagon nut	Ecrou hexagonale	980	M20
49	023-02-049	2	2	2	Sechskantschraube	Hexagon head screw	Vis hexagonale	933	M20x60
50	061-01-013	1	1	1	Spannbuchse	Clamping bush	Douille de serrage		3030155
Ersatzteilgruppe: Winkelgetriebe UFM							Baugruppe: 20		
Spare parts group: Bevel gear									
Groupe de pièces de rechange: Engrenage conique									

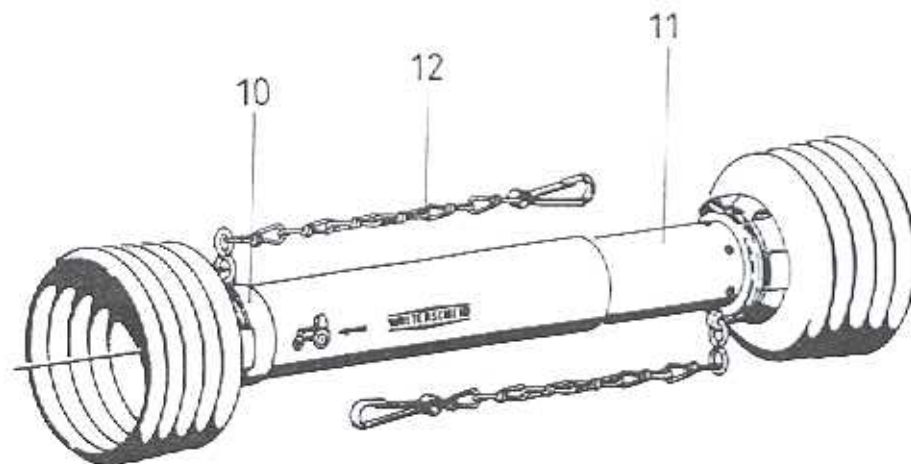
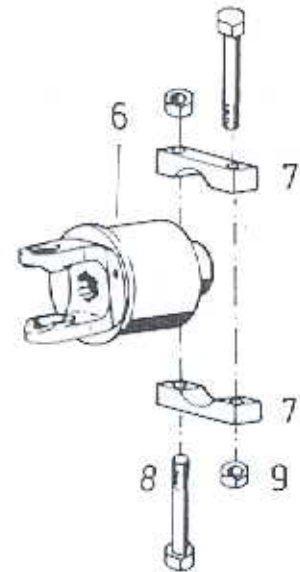
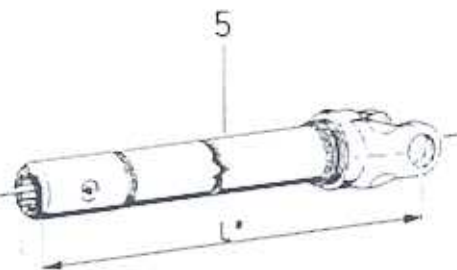
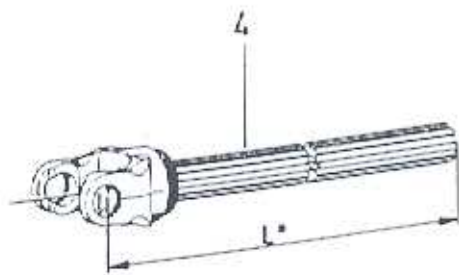
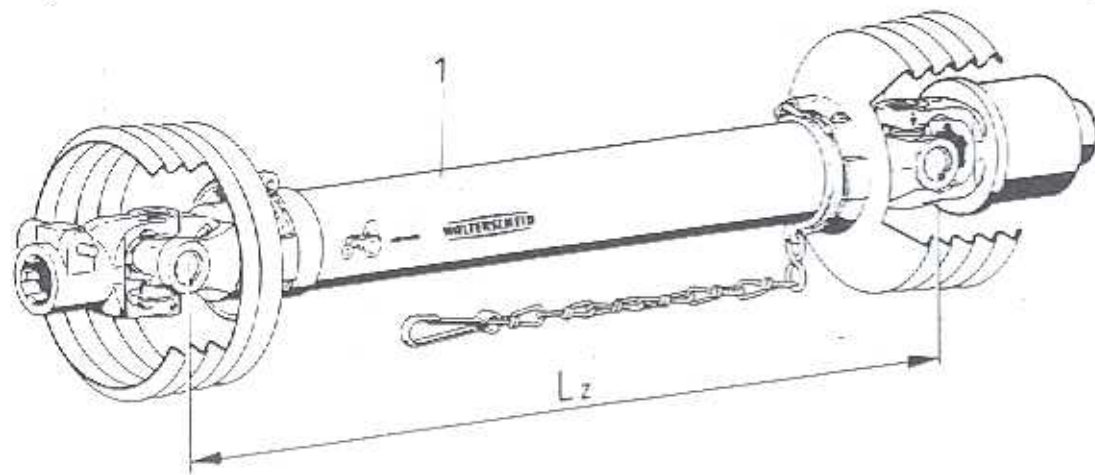

Pos.	Teile-Nr. Part-Nr. Piece-Nr.	Quant.			Benennung	Description	Désignation	DIN Norm	Maße Dimens.
		150	180	225					
1	125-04-010	1	1	1	Gelenkwelle	Cardan shaft	Arbre de transmission	1 3/8"	6-tlg.
	125-04-012	1	1	1	Gelenkwelle	Cardan shaft	Arbre de transmission	1 3/8"	21-tlg.
	125-04-014	1	1	1	Gelenkwelle	Cardan shaft	Arbre de transmission	1 3/4"	6-tlg.
	125-04-016	1	1	1	Gelenkwelle	Cardan shaft	Arbre de transmission	1 3/4"	20-tlg.
	125-04-018	1	1	1	Gelenkwelle	Cardan shaft	Arbre de transmission	1 3/8"	6-tlg.
	125-04-020	1	1	1	Gelenkwelle	Cardan shaft	Arbre de transmission	1 3/8"	21-tlg.
	125-04-022	1	1	1	Gelenkwelle	Cardan shaft	Arbre de transmission	1 3/4"	6-tlg.
	125-04-024	1	1	1	Gelenkwelle	Cardan shaft	Arbre de transmission	1 3/4"	20-tlg.
2	125-04-140	1	1	1	Aufsteckgabel	Quick disconnect yoke	Mâchoire à verrouillage	1 3/8"	6-tlg.
	125-04-142	1	1	1	Aufsteckgabel	Quick disconnect yoke	Mâchoire à verrouillage	1 3/8"	21-tlg.
	125-04-144	1	1	1	Aufsteckgabel	Quick disconnect yoke	Mâchoire à verrouillage	1 3/4"	6-tlg.
	125-04-146	1	1	1	Aufsteckgabel	Quick disconnect yoke	Mâchoire à verrouillage	1 3/4"	20-tlg.
3	125-04-124	2	2	2	Kreuzgarnitur	Cross and bearing kit	Cossillon cpl.		
4	125-04-126	1	1	1	Wellengabel Innenteil	Outer welded shaft	Mâchoire à embout profilé soudé ext.		
5	125-04-132	1	1	1	Wellengabel Außenteil	Inner welded shaft	Mâchoire à embout profilé soudé int.		
6	125-04-136	1	1	1	Freilaufkupplung F5/1R	Overrunning clutch	Roue libre à rochets	1 3/4"	20-tlg.
	125-04-138	1	1	1	Freilaufkupplung F5/1L	Overrunning clutch	Roue libre à rochets	1 3/4"	20-tlg.
7	125-04-200	2	2	2	Brücke	Bridge	Poutet		
8	022-02-030	2	2	2	Sechskantschraube	Hexagon head screw	Vis hexagonale	931	M16x110
9	029-01-007	2	2	2	Sechskantmutter	Hexagon nut	Ecrou hexagonale	980	M16
10	125-04-182	1	1	1	Schutzhälfte außen	Outer guard half	Demi-protecteur ext.		
11	125-04-172	1	1	1	Schutzhälfte innen	Inner guard half	Demi-protecteur int.		
Ersatzteilgruppe: Gelenkwelle mit Freilaufkupplung						Baugruppe: 20			
Spare parts group: PTO-shaft with overrunning clutch									
Groupe de pièces de rechange: Transmission avec roue libre à rochets									

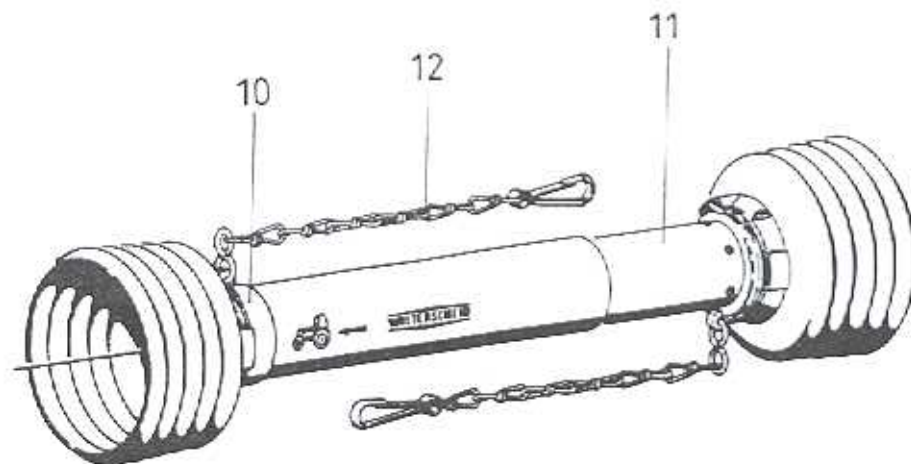
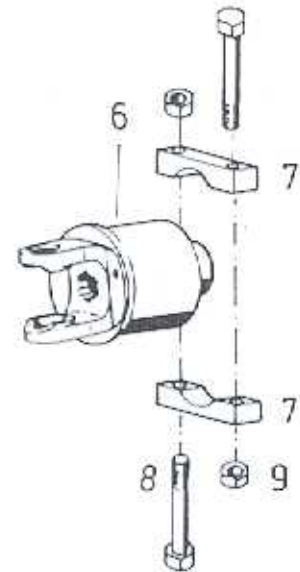
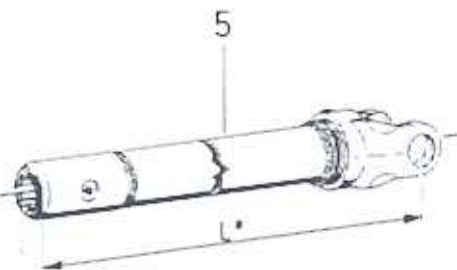
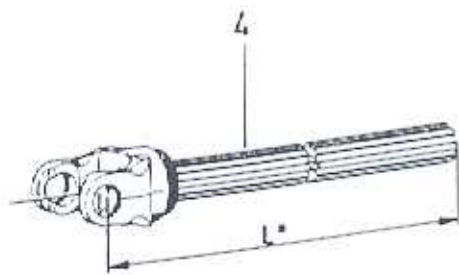
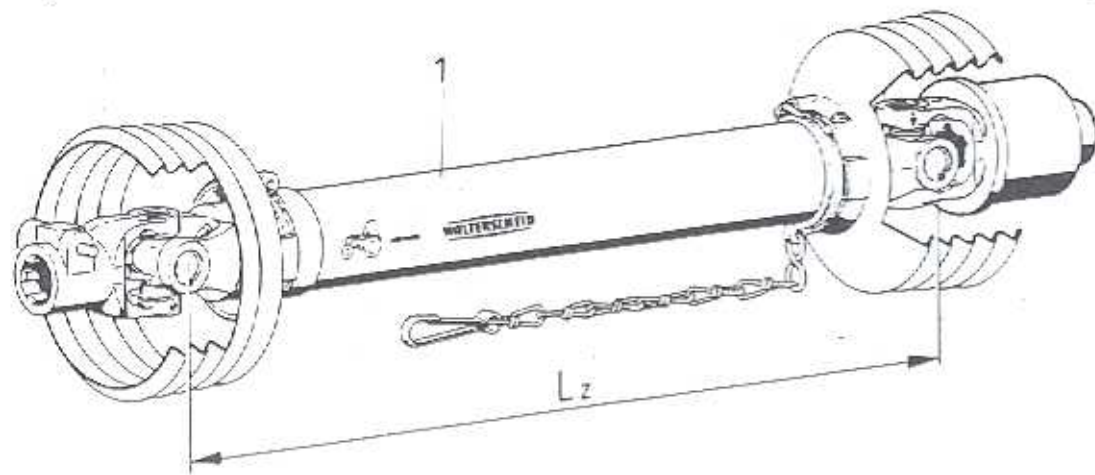

Pos.	Teile-Nr. Part-Nr. Piece-Nr.	Quant.			Benennung	Description	Désignation	DIN Norm	Maße Dimens.
		150	180	225					
12	125-01-160	2	2	2	Haltekette	Safety chain	Chaînette		
Ersatzteilgruppe:					Gelenkwelle mit Freilaufkupplung	Baugruppe: 20			
Spare parts group:					PTO-shaft with overrunning clutch				
Groupe de pièces de rechange:					Transmission avec roue libre à rochets				

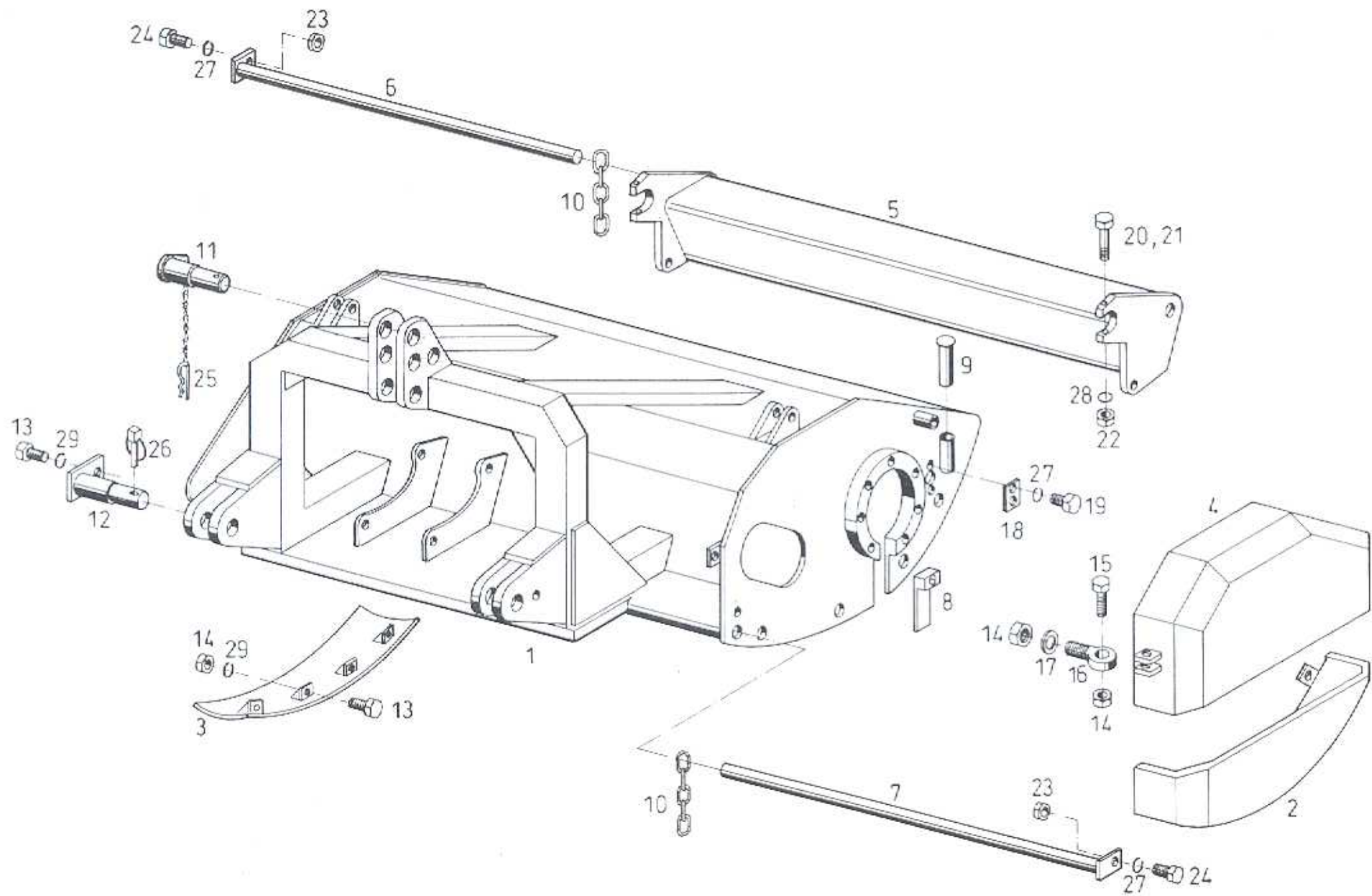

Pos.	Teile-Nr. Part-Nr. Piece-Nr.	Quant.			Benennung	Description	Désignation	DIN Norm	Maße Dimens.
		150	180	225					
1	423-30-010	1			Hauptrahmen	Main frame	Cadre principal		
	423-30-011		1		Hauptrahmen	Main frame	Cadre principal		
	423-30-012			1	Hauptrahmen	Main frame	Cadre principal		
2	423-30-028	1	1	1	Kufe li.	Skid left	Patin gauche		
3	423-30-029	1	1	1	Kufe re.	Skid right	Patin droite		
4	423-30-026	1	1	1	Keilriemenschutz	V-belt protection	Protection de courrie		
5	423-30-004	1			Schutzklappe	Protection flap	Volet de protection		
	423-30-005		1		Schutzklappe	Protection flap	Volet de protection		
	423-30-006			1	Schutzklappe	Protection flap	Volet de protection		
6	423-30-021	1			Haltewelle	Support rod	Tige support		
	423-30-022		1		Haltewelle	Support rod	Tige support		
	423-30-023			1	Haltewelle	Support rod	Tige support		
7	423-30-017	1			Haltewelle	Support rod	Tige support		
	423-30-018		1		Haltewelle	Support rod	Tige support		
	423-30-019			1	Haltewelle	Support rod	Tige support		
8	423-30-007	1	1	1	Einsetzblech	Plate	Tôle		
	423-30-008	1	1	1	Einsetzblech	Plate	Tôle		
9	423-30-027	1	1	1	Bolzen	Bolt	Boulon		
10	059-01-001	85	107	131	Kette	Chain	Chaîne	5685	G 10x40
11	423-30-025	1	1	1	Oberlenkerbolzen	Top link pin	Boulon de direct. sup.		
12	423-30-024	2	2	2	Unterlenkerbolzen	Bottom link pin	Boulon de direct. inf.		
13	023-02-038	9	9	9	Sechskantschraube	Hexagon head screw	Vis hexagonale	933	M16x40
Ersatzteilgruppe:					Hauptrahmen		Baugruppe: 30		
Spare parts group:					Main frame				
Groupe de pièces de rechange:					Cadre principale				

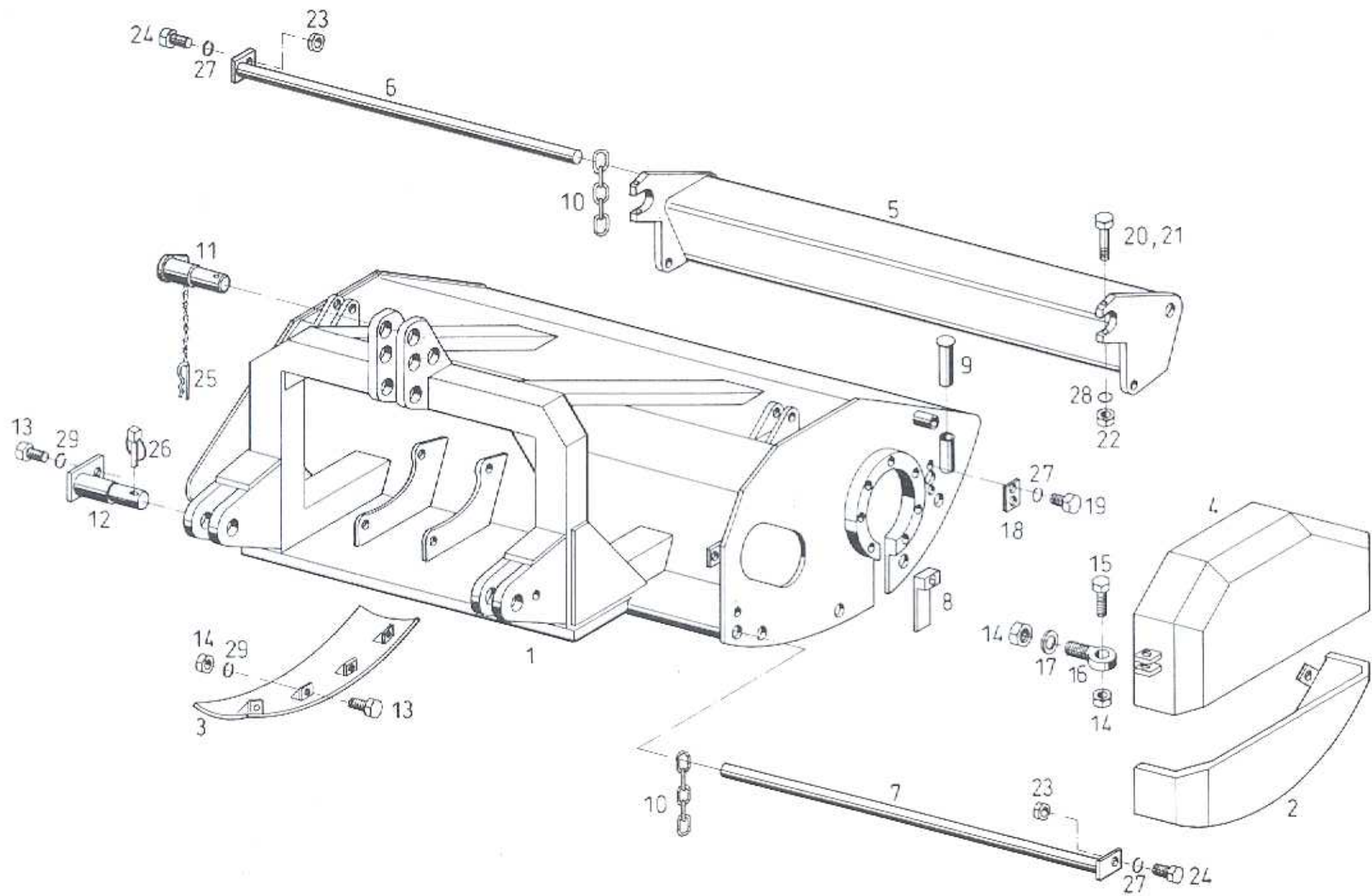

Pos.	Teile-Nr. Part-Nr. Piece-Nr.	Quant.			Benennung	Description	Désignation	DIN Norm	Maße Dimens. M16x40
		150	180	225					
14	029-01-007	9	9	9	Sechskantmutter	Hexagon nut	Ecrou hexagonale	980	M16
15	023-02-040	1	1	1	Sechskantschraube	Hexagon head screw	Vis hexagonale	933	M16x50
16	008-01-003	1	1	1	Augenschraube	Eye bolt	Boulon à oeillet	444	M16x100
17	003-02-006	1	1	1	Scheibe	Washer	Rondelle	125	B17
18	423-31-083	1	1	1	Deckel	Cover	Couvercle		
19	023-02-014	2	2	2	Sechskantschraube	Hexagon head screw	Vis hexagonale	933	M10x20
20	022-02-017	2	2	2	Sechskantschraube	Hexagon head screw	Vis hexagonale	931	M12x90
21	022-02-018	2	2	2	Sechskantschraube	Hexagon head screw	Vis hexagonale	931	M12x100
22	029-01-005	2	2	2	Sechskantmutter	Hexagon nut	Ecrou hexagonale	980	M12
23	029-01-004	2	2	2	Sechskantmutter	Hexagon nut	Ecrou hexagonale	980	M10
24	023-02-016	2	2	2	Sechskantschraube	Hexagon head screw	Vis hexagonale	933	M10x25
25	051-01-002	1	1	1	Federstecker	Folding plug	Clavette	11024	∅ 4
26	050-01-001	2	2	2	Klappstecker	Clasping splint	Goupille pliant	11023	∅ 9,5
27	004-01-003	4	4	4	Federring	Spring washer	Rondelle élastique	127	∅ 10
28	004-01-004	2	2	2	Federring	Spring washer	Rondelle élastique	127	∅ 12
29	004-01-006	9	9	9	Federring	Spring washer	Rondelle élastique	127	∅ 16
Ersatzteilgruppe: Hauptrahmen							Baugruppe: 30		
Spare parts group: Main frame									
Groupe de pièces de rechange: Cadre principale									

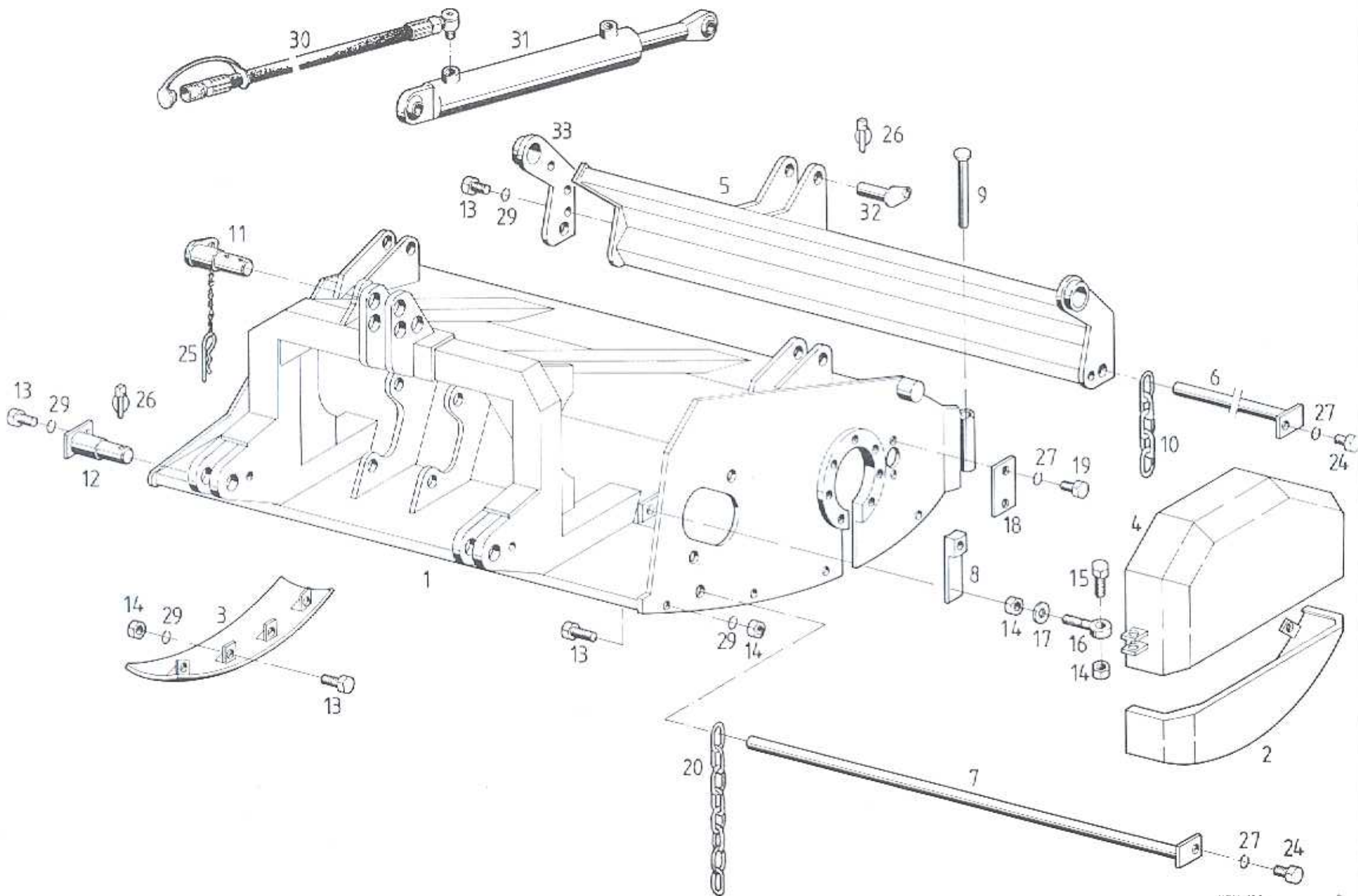

Pos.	Teile-Nr. Part-Nr. Piece-Nr.	Quant.			Benennung	Description	Désignation	DIN Norm	Maße Dimens.
		150	180	225					
1	423-30-041	1			Hauptrahmen	Main frame	Cadre principal		
	423-30-042		1		Hauptrahmen	Main frame	Cadre principal		
	423-30-043			1	Hauptrahmen	Main frame	Cadre principal		
2	423-30-028	1	1	1	Kufe li.	Skid left	Patin gauche		
3	423-30-029	1	1	1	Kufe re.	Skid right	Patin droite		
4	423-30-026	1	1	1	Keilriemenschutz	V-belt protection	Protection de courrie		
5	423-30-038	1			Schutzklappe	Protection flap	Volet de protection		
	423-30-039		1		Schutzklappe	Protection flap	Volet de protection		
	423-30-040			1	Schutzklappe	Protection flap	Volet de protection		
6	423-30-021	1			Haltewelle	Support rod	Tige support		
	423-30-022		1		Haltewelle	Support rod	Tige support		
	423-30-023			1	Haltewelle	Support rod	Tige support		
7	423-30-017	1			Haltewelle	Support rod	Tige support		
	423-30-018		1		Haltewelle	Support rod	Tige support		
	423-30-019			1	Haltewelle	Support rod	Tige support		
8	423-30-007	1	1	1	Einsetzblech li.	Insert plate, rear	Tôle à insérer, arrière		
	423-30-008	1	1	1	Einsetzblech re.	Insert plate, rear	Tôle à insérer, arrière		
9	423-30-027	1	1	1	Bolzen	Bolt	Boulon		
10	059-01-001	44	57	67	Kette	Chain	Chaîne	5685	G 10x40
11	423-30-025	1	1	1	Oberlenkerbolzen	Top link pin	Boulon de direct. sup.		
12	423-30-024	2	2	2	Unterlenkerbolzen	Bottom link pin	Boulon de direct. inf.		
13	023-02-038	9	9	9	Sechskantschraube	Hexagon head screw	Vis hexagonale	933	M16x40
Ersatzteilgruppe:					Hauptrahmen	Baugruppe: 30			
Spare parts group:					Main frame				
Groupe de pièces de rechange:					Cadre principale				

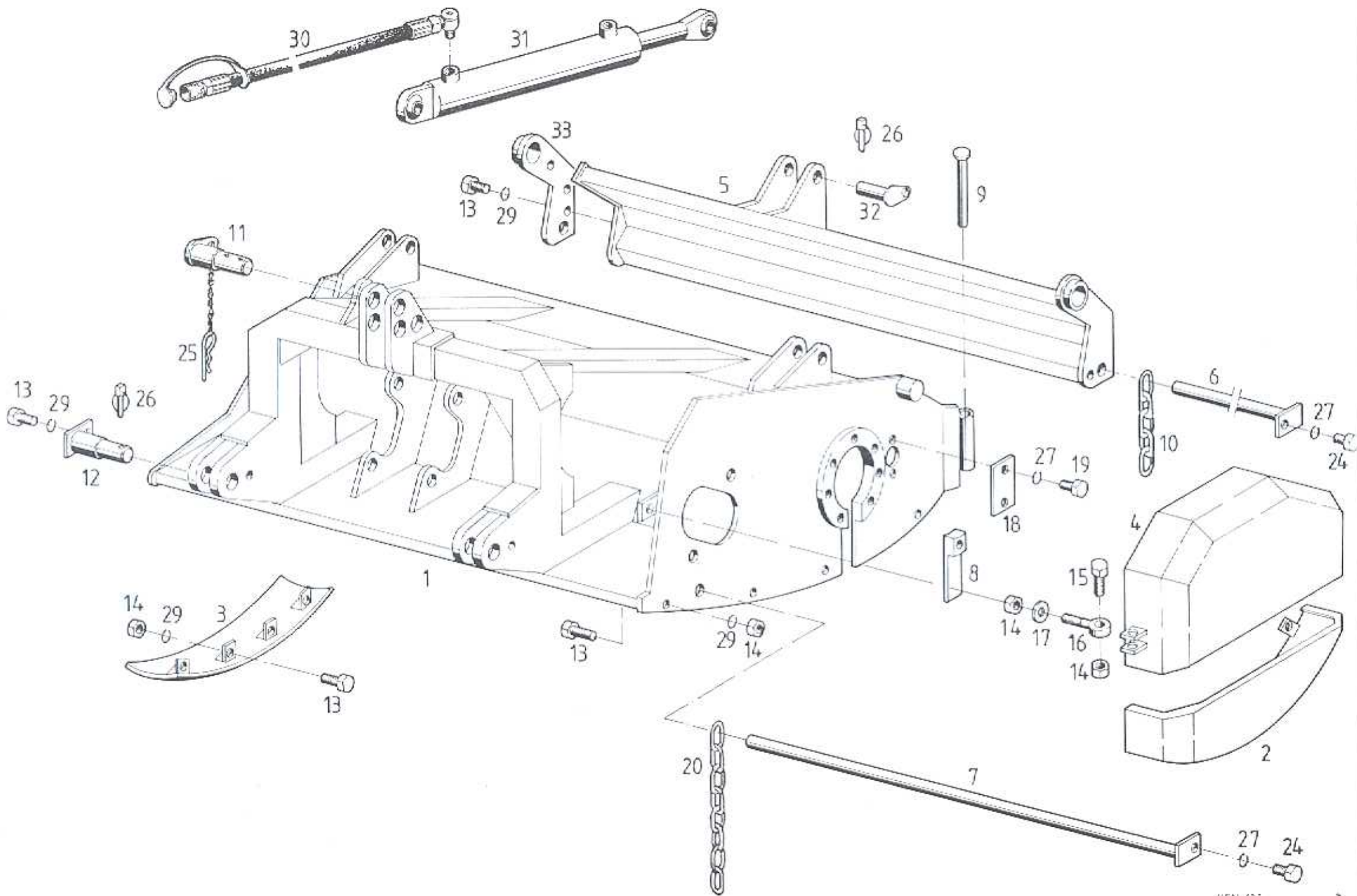

Pos.	Teile-Nr. Part-Nr. Piece-Nr.	Quant.			Benennung	Description	Désignation	DIN Norm	Maße Dimens.
		150	180	225					
14	029-01-007	9	9	9	Sechskantmutter	Hexagon nut	Ecrou hexagonale	980	M16
15	023-02-040	1	1	1	Sechskantschraube	Hexagon head screw	Vis hexagonale	933	M16x50
16	008-01-003	1	1	1	Augenschraube	Eye bolt	Boulon à oeillet	444	M16x100
17	003-02-006	1	1	1	Scheibe	Washer	Rondelle	125	B 17
18	423-31-083	1	1	1	Deckel	Cover	Couvercle		
19	023-02-014	2	2	2	Sechskantschraube	Hexagon head screw	Vis hexagonale	933	M10x20
20	059-01-003	41	50	64	Kette	Chain	Chaîne		
24	023-02-016	2	2	2	Sechskantschraube	Hexagon head screw	Vis hexagonale	933	M10x25
25	051-01-002	1	1	1	Federstecker	Folding plug	Clavette	11024	∅ 6
26	050-01-001	4	4	4	Klappstecker	Clasping splint	Goupille pliant	11023	∅ 9,5
27	004-01-003	4	4	4	Federring	Spring washer	Rondelle élastique	127	∅ 10
28	004-01-004	2	2	2	Federring	Spring washer	Rondelle élastique	127	∅ 12
29	004-01-006	13	13	13	Federring	Spring washer	Rondelle élastique	127	∅ 16
30	230-11-041	2	2	2	Schlauch	Hose	Tuyau		
31	700-51-009	1	1	1	Hydraulikzylinder	Hydraulic cylinder	Cylinder hydraulique		
32	423-50-012	2	2	2	Bolzen	Bolt	Boulon		
33	423-30-045	1	1	1	Seitenteil	Side sheet	Tôle latérale		
Ersatzteilgruppe: Hauptrahmen							Baugruppe: 30		
Spare parts group: Main frame									
Groupe de pièces de rechange: Cadre principale									

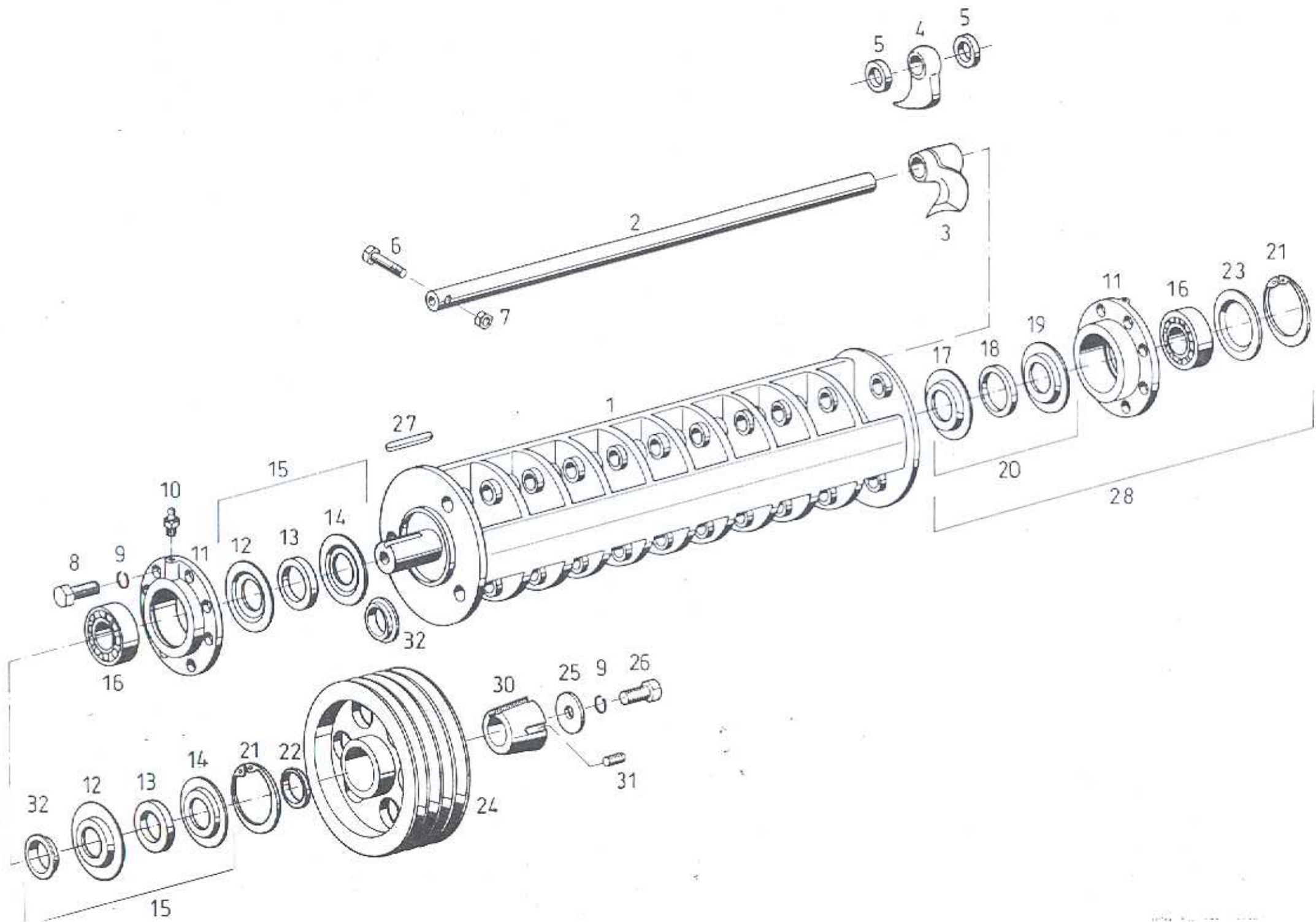

Pos.	Teile-Nr. Part-Nr. Piece-Nr.	Quant.			Benennung	Description	Désignation	DIN Norm	Maße Dimens.
		150	180	225					
1	423-40-019	1			Rotor	Rotor			
	423-40-020		1		Rotor	Rotor			
	423-40-021			1	Rotor	Rotor			
	423-40-033	1			Rotor mont.	Rotor compl.			
	423-40-034		1		Rotor mont.	Rotor compl.			
	423-40-035			1	Rotor mont.	Rotor compl.			
2	660-41-017	3			Steckwelle	Full floating axle			
	423-41-004		3		Steckwelle	Full floating axle			
	423-41-005			3	Steckwelle	Full floating axle			
3	420-30-022	27	36	45	Schlegel	Flail			
4	423-41-065	27	36	45	Schlegel	Flail			
5	423-41-063	54	68	90	Distanzscheibe	Spacer ring			
6	022-02-022	3	3	3	Sechskantschraube	Hexagon head screw		M 14x70	
7	029-01-004	6	6	6	Sechskantmutter	Hexagon nut		M 10	
8	023-02-039	16	16	16	Sechskantschraube	Hexagon head screw		M 16x45	
9	004-01-006	17	17	17	Federring	Spring washer		A 16	
10	052-01-003	2	2	2	Schmiernippel	Grease nipple		AM 8	
11	421-40-018	2	2	2	Lagergehäuse	Bearing housing			
12	421-41-020	2	2	2	Deckscheibe	Cover disk			
13	066-01-005	2	2	2	Lamellenring	Compound		∅ 80	
14	421-41-021	2	2	2	Deckscheibe	Cover disk			
15	421-40-012	2	2	2	Dichtungssatz	Seal set			
Ersatzteilgruppe:					Rotor		Baugruppe: 40		
Spare parts group:					Rotor				
Groupe de pièces de rechange:					Rotor				

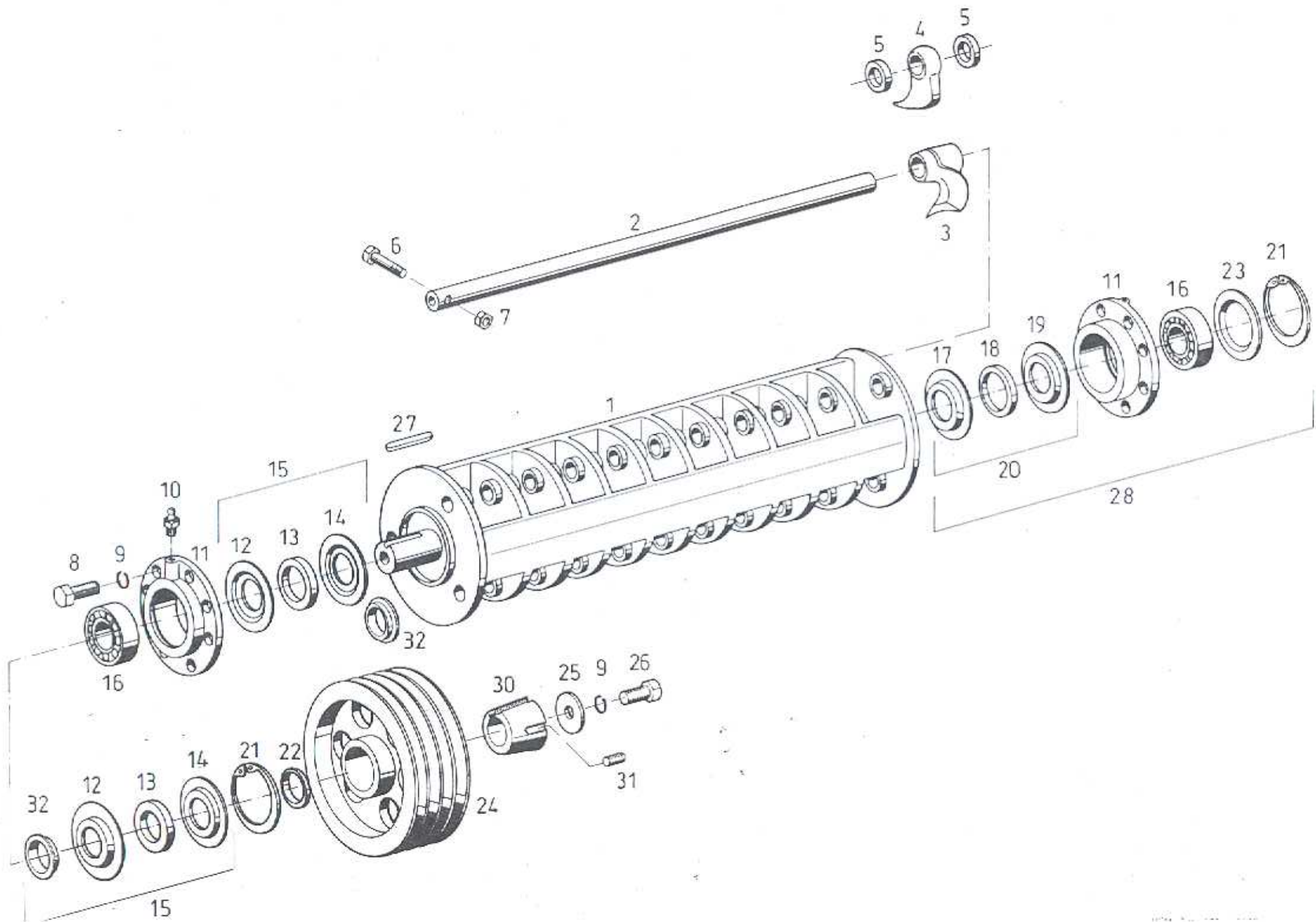

Pos.	Teile-Nr. Part-Nr. Piece-Nr.	Quant.			Benennung	Description	Désignation	DIN Norm	Maße Dimens.
		150	180	225					
16	014-02-009	2	2	2	Pendelrollenlager	Roller bearing	Roulement à rotule	720	22313
17	421-41-023	1	1	1	Deckscheibe	Cover disk	Disque de recouvrement		
18	066-01-001	1	1	1	Lamellenring	Compound	Lamelle d'etancheite		∅ 65
19	421-41-024	1	1	1	Deckscheibe	Cover disk	Disque de recouvrement		
20	421-40-011	1	1	1	Dichtungssatz	Seal set	Joint compl.		
21	011-01-026	2	2	2	Sicherungsring	Circlip	Circlip	472	∅ 140
22	421-41-069	1	1	1	Distanzring	Spacer ring	Bague d'écartement		
23	421-41-013	1	1	1	Deckscheibe	Cover disk	Disque de recouvrement		
24	423-41-100	1	1	1	Keilriemenscheibe	V-belt pulley	Poulie		∅ 325
25	660-41-156	1	1	1	Scheibe	Washer	Rondelle		
26	023-06-008	1	1	1	Sechskantschraube	Hexagon head screw	Vis hexagonale		
27	042-01-016	1	1	1	Paßfeder	Feather key	Ressort d'ajustage		
28	423-40-031	1	1	1	Lagerung kpl. re.	Bearing compl.	Palier compl.		
29	423-40-032	1	1	1	Lagerung kpl. li.	Bearing compl.	Palier compl.		
30	061-01-007	1	1	1	Spannbuchse	Clamping bush	Douille de serrage		3030-65
31	061-03-005	2	2	2	Gewindestift	Grub screw	Cheville feletée		⁵ / ₈ " BSW
32	421-41-068	2	2	2	Dichtring	Seal ring	Bague etancheite		
Ersatzteilgruppe:						Rotor	Baugruppe: 40		
Spare parts group:						Rotor			
Groupe de pièces de rechange:						Rotor			

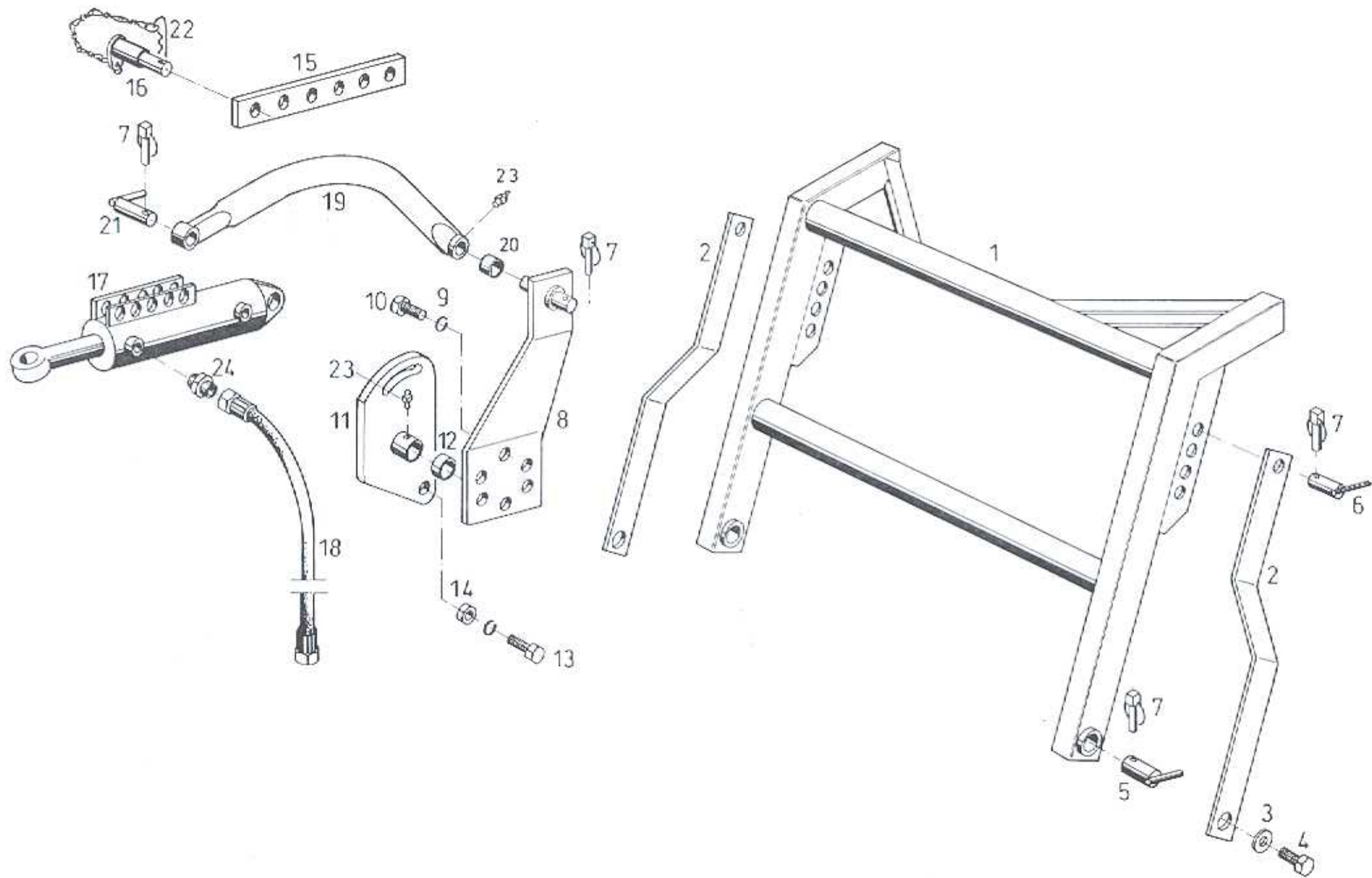

Pos.	Teile-Nr. Part-Nr. Piece-Nr.	Quant.			Benennung	Description	Désignation	DIN Norm	Maße Dimens.
		150	180	225					
1	423-50-009	1			Drückevorrichtung	Press-down equipm.	Dispositif pousse-branches		
	423-50-010		1		Drückevorrichtung	Press-down equipm.	Dispositif pousse-branches		
	423-50-011			1	Drückevorrichtung	Press-down equipm.	Dispositif pousse-branches		
2	423-51-025	2	2	2	Stütze	Support	Support		
3	660-41-156	2	2	2	Scheibe	Washer	Rondelle		
4	023-02-038	2	2	2	Sechskantschraube	Hexagon head screw	Vis hexagonale	933	M 16x40
5	423-50-012	2	2	2	Bolzen	Bolt	Boulon		
6	423-50-013	2	2	2	Bolzen	Bolt	Boulon		
7	050-01-001	6	6	6	Klappstecker	Clasping splint	Goupille pliant	11023	∅ 9,5
8	423-50-001	1	1	1	Hebel	Lever	Levier		
9	004-01-006	6	6	6	Federring	Spring washer	Rondelle élastique	127	A 16
10	023-02-037	6	6	6	Sechskantschraube	Hexagon head screw	Vis hexagonale	933	M 16x35
11	423-50-002	1	1	1	Lagerplatte	Bearing plate	Plaque de palier		
12	064-01-007	1	1	1	Lagerbuchse	Bearing bush	Coussinet		∅ 45x50x40
13	023-02-049	2	2	2	Sechskantschraube	Hexagon head screw	Vis hexagonale	933	M 20x60
14	029-01-009	2	2	2	Sechskantmutter	Hexagon nut	Ecrou hexagonale	980	M 20
15	423-51-006	1	1	1	Feststellschiene	Locking bar	Barre de verrouillage		
16	423-30-025	1	1	1	Bolzen	Bolt	Boulon		
17	423-50-008	1	1	1	Hydraulikzylinder	Hydraulic cylinder	Cylinder hydraulique		
18	423-51-014	2	2	2	Hydraulikschlauch	Hydraulik hose	Tuyau hydraulique		
19	423-50-006	1	1	1	Steuerbügel	Steering bracket	Traverse de direction		
20	064-01-003	1	1	1	Lagerbuchse	Bearing bush	Coussinet		∅ 30x34x30
Ersatzteilgruppe:						Sonderanbauten		Baugruppe: 50	
Spare parts group:						Extra parts			
Groupe de pièces de rechange:						Accessoires spéciales			

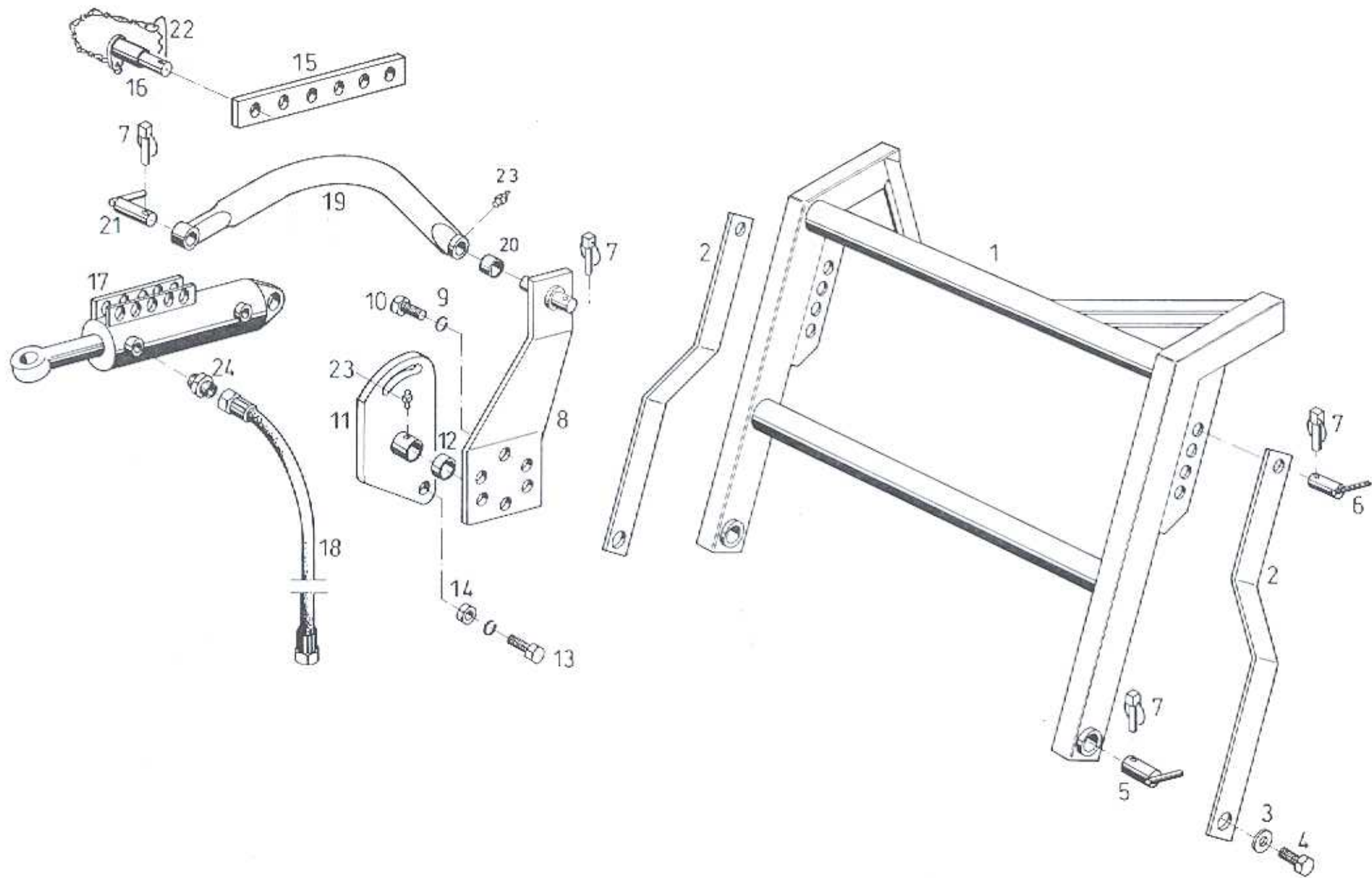

Pos.	Teile-Nr. Part-Nr. Piece-Nr.	Quant.			Benennung	Description	Désignation	DIN Norm	Maße Dimens.
		150	180	225					
21	423-50-007	1	1	1	Bolzen	Bolt	Boulon		
22	051-01-002	1	1	1	Federstecker	Folding plug	Clavette	11024	∅ 4
23	052-01-001	2	2	2	Schmiernippel	Grease nipple	Graisneur	71412	AM 6
24	036-02-002	2	2	2	Verschraubung	Union	Raccord filteté		GE12-LM 18x1,5
Ersatzteilgruppe: Sonderanbauten							Baugruppe: 50		
Spare parts group: Extra parts									
Groupe de pièces de rechange: Accessoires spéciales									

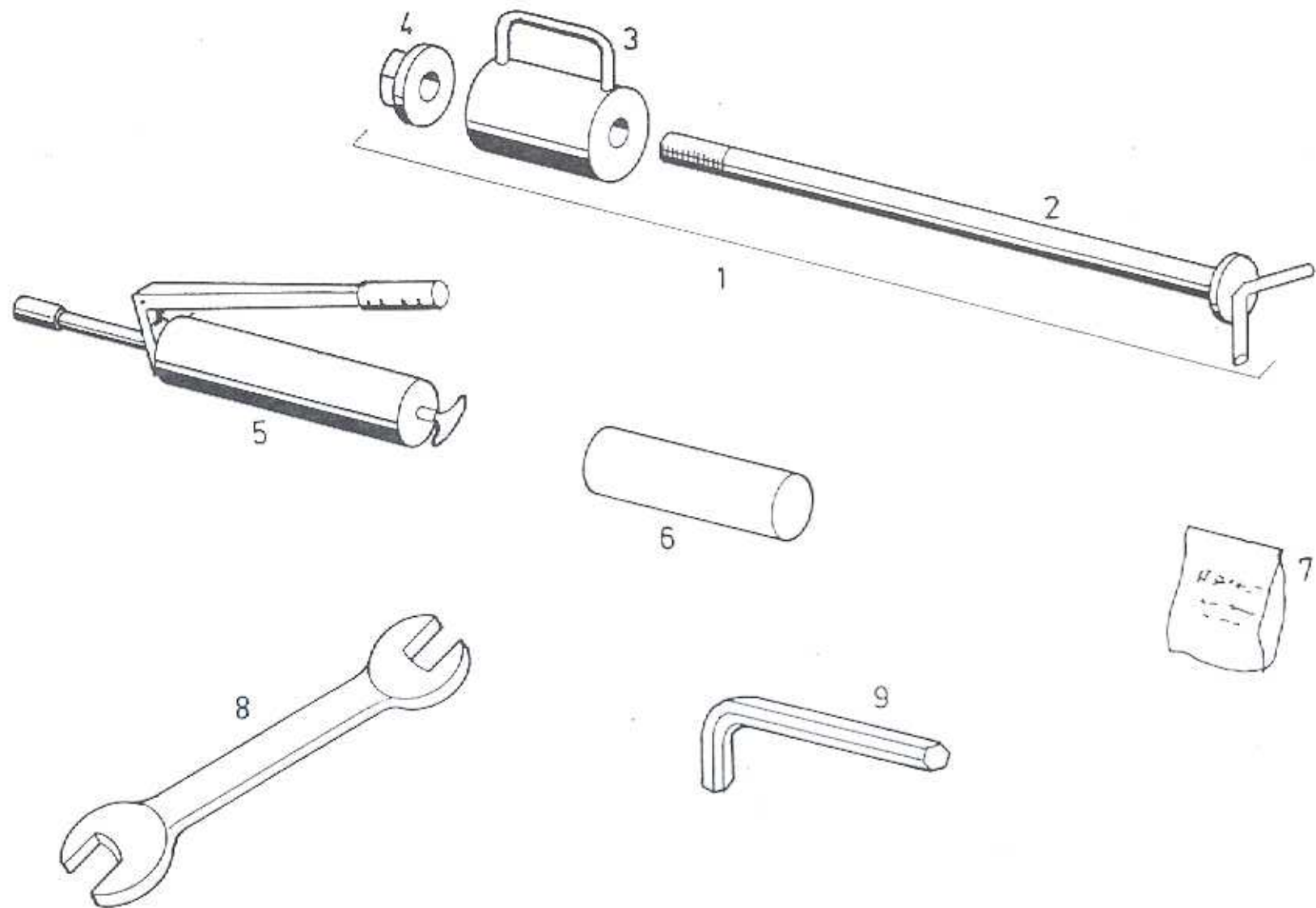

Pos.	Teile-Nr. Part-Nr. Piece-Nr.	Quant.			Benennung	Description	Désignation	DIN Norm	Maße Dimens.
		150	180	225					
1	660-80-001	1	1	1	Schlagvorrichtung	Percussion tool	Outil de percussion		
2	423-80-001	1	1	1	Führungsstange	Guide rod	Tige conductrice		
3	423-80-002	1	1	1	Schlaggewicht	Striking weight	Poids		
4	660-80-004	1	1	1	Mutter	Nut	Ecrou		
5	660-81-001	1	1	1	Fettpresse	Grease pump	Pompe à graisse		
6	660-81-002	1	1	1	Nachfüllpatrone	Grease cartridge	Cartouche de graisse		
7	660-81-003	4	4	4	Gleitmetall	Grease for flailaxle	Grease pour l'fleau axe		
8	117-01-001	1	1	1	Gabelschlüssel	Forked spanner	Clé á plate	895	13/17
	117-01-002	1	1	1	Gabelschlüssel	Forked spanner	Clé á plate	895	17/19
	117-01-003	1	1	1	Gabelschlüssel	Forked spanner	Clé á plate	895	19/24
	117-01-004	1	1	1	Gabelschlüssel	Forked spanner	Clé á plate	895	24/30
9	118-01-003	1	1	1	Sechskant-Schraubendreher	Hexagon screwdriver	Turnevis hexagonal	911	SW 8
	118-01-004	1	1	1	Sechskant-Schraubendreher	Hexagon screwdriver	Turnevis hexagonal	911	SW 10
Ersatzteilgruppe:						Werkzeugsatz		Baugruppe: 80	
Spare parts group:						Tool set			
Groupe de pièces de rechange:						Jew d'outils			