



**WILLIBALD**  
RECYCLING TECHNOLOGY



# MINISHARK

SHREDDING - SCREENING - TURNING

# OPTIMIZED FOR SMALL & MEDIUM-SIZED PROJECTS

# MS 3000 MINISHARK

---

With its innovative shredding system the MINISHARK reliably processes a wide range of organic materials and is convincing in terms of performance and economy especially for small and medium throughput rates. The compact shredder also incorporates the most excellent innovations of the successful EP 5500 SHARK series.

We supply all MS 3000 processing machines with Perkins engines of the latest generation and exhaust gas stage as a standard. A caterpillar or stationary version is possible where relevant, and a full electric propulsion is establishing itself increasingly on the market. In addition, we offer a number of other useful extras to cover all customer-specific requirements and enable cost-effective and convenient working.

In order to respond more specifically to the individual input material, two rotor versions with 18 free-swinging flails or fixed tools are available.





View of maintenance position



Electric version



Caterpillar version

## Special machine features:

Excellent maintenance accessibility by unique service position of the discharge belt

The feeding speed is controlled proportionally dependent on the load

Radio-controlled adjustment of the material grain at any time by changing the distance between the rakes (counter-blades) and the rotor

Various quick-change post-shredding flaps for exact final grain

A reversible fan for cyclic cleaning of the cooler surface



## SUITABLE MATERIALS:

The MINISHARK can be used flexibly for processing organic materials such as green waste, biomass, old timber, pallets, bark, peat, biogas substrate (e.g. sugar beet, potatoes, onions, carrots, manure, grass and corn silage).

Hereby, the initial material is fed in doses to the rotor over a roller floor and the infeed roller and shredded by the hammer mill principle. The end product size and its defibration correspond here to composting requirements and enable intensive and even rotting. Different quick-change screening baskets can be used to flexibly influence the desired final grain.



Roller floor / infeed roller

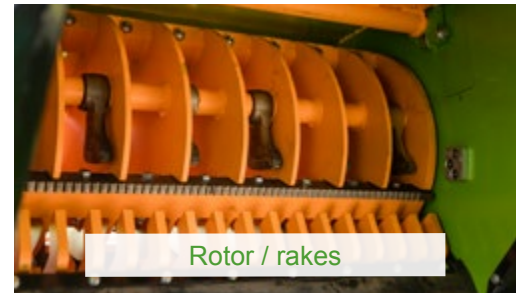

Rotor / rakes



Cutting up flap

## THROUGHPUT RATES:

Green waste	up to 60 m <sup>3</sup> /h
Old timber	up to 40 m <sup>3</sup> /h
Old pre-broken timber	up to 60 m <sup>3</sup> /h
Bark	up to 60 m <sup>3</sup> /h
Livestock excrements (e.g. manure)	up to 50 m <sup>3</sup> /h



Compost soil, natural manure

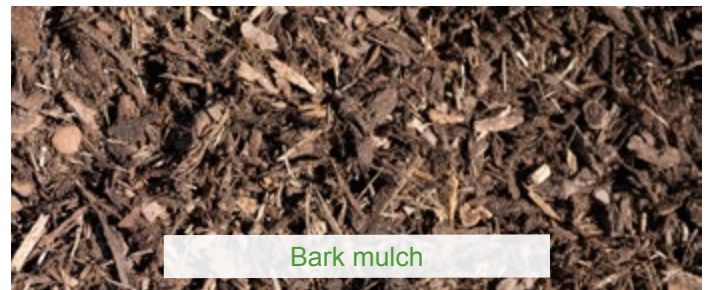

Bark mulch

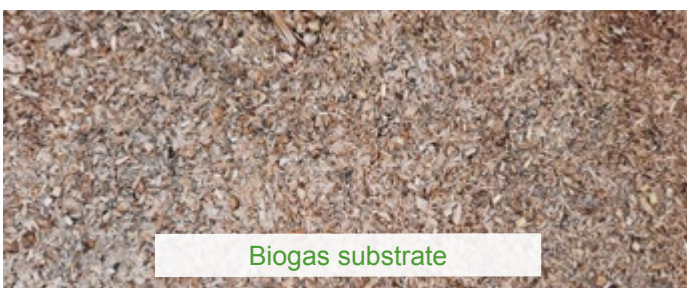

Biogas substrate



Wood chips

## Engine

The MINISHARK is equipped with a Perkins 4-cylinder diesel engine with 176 h.p. In the latest emission class as a standard propulsion system. A performance upgrade is also available. We also offer a fully electric version as an alternative.



## Radio remote control

Allows convenient and reliable machine operation of all important functions and basic settings such as infeed speed from the feeding vehicle.



## OUR EQUIPMENT VARIETY THAT INSPIRES.



## Hydraulic support leg

Is part of the standard equipment and enables convenient height adjustment of the drawbar from the control panel or via radio remote control.

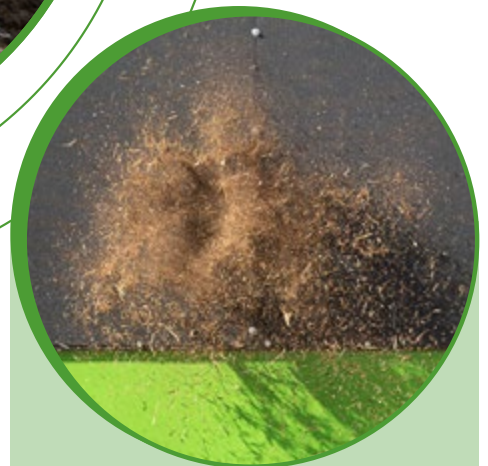

## Reversible fan

The reversible fan, which is already mounted in the basic machine, ensures a cyclic cleaning of the cooler surface to remove attracted dust.

## Other options



**Crawling speed drive**  
enables continuous depositing of the shredded material into closed windrows.

**Central lubrication system**  
supplies all lubricating points at adjustable intervals with the required exact dose of grease.



**Water spray system**  
prevents dust development both on the transport belt and on the discharge belt. An ideal extra option, for example, when shredding pallets.

**Quick-release axle system**  
for convenient extraction of the flail axles from the rotor for quick tool changes.



**Neodymium magnet roller**  
Pieces of metal in the shredded material are extracted and separated.

**Work light**  
Three LED work lights illuminate the work area perfectly. Ideal for use in shift operation.



**Various cutting up flaps**  
Different sizes of screening baskets are available for installation depending on the requirements for the desired end product (final grain grade).

## Open for new ideas

Individual customer requests are possible after examination. We look forward to your challenges.

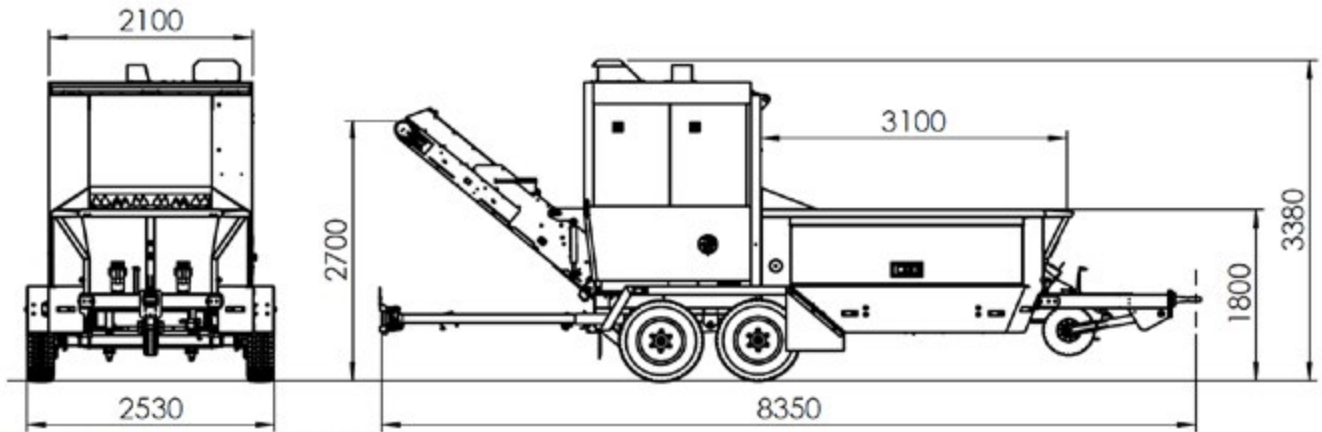

dimensions working position

## Technical data MINISHARK

Transport measurements	(LxWxH) 8350/2530/3380	
Engine	Standard	Upgrade
Manufacturer	Perkins	Perkins
Type	1204J-E44TTA	1204J-E44TTA
Power	130 kW / 176 HP	140 kW / 190 HP
Emission	ECE Stage V	
Chassis	2 axle central chassis for 80 km/h (50 m/h)	
Permissible total weight	10000 kg	
<b>Rotor</b>		
Weight (equipped)	ca. 550 kg	
Width	1250 mm	
Diameter	700 mm	
Flails (pcs.)	18	
Milling strips/ scrapers (pcs.)	6 / 0	
Approx. flail weight	ca. 3,5 kg	
Endless floor	infinitely variable speed	
Infeed Roller	infinitely variable speed	
Maximal infeed height	300 mm	
Rakes and screens	position adjustable separately	

The specified parameters refer to the standard machine.  
Dimensions and specifications can differ due to equipment options.



Visit the Willibald YouTube channel  
and see our machines in action.



# **WILLIBALD**

## **RECYCLING TECHNOLOGY**

---

### **HEADQUARTERS**

J. Willibald GmbH  
Recyclingtechnik  
Bahnhofstr. 6  
88639 Wald-Sentenhart  
Germany

Tel.: +49 (0)7578/189-0  
Fax: +49 (0)7578/189-170

[info@willibald-gmbh.de](mailto:info@willibald-gmbh.de)  
[www.willibald-gmbh.de](http://www.willibald-gmbh.de)

### **BRANCH OFFICE**

Willibald Service- &  
Instandsetzungszentrum  
Im Wolfsgraben 5  
36414 Unterbreizbach  
Germany

Tel.: +49 (0)36962/514-10  
Fax: +49 (0)36962/514-18

[info.ubba@willibald-gmbh.de](mailto:info.ubba@willibald-gmbh.de)